

CAMBIA AUTOMATION LIMITED

Triconex 4329

DATASHEET

CAMBIA GROUP

2017

CONTACT EMAIL: SALES@CAMBIA.CN

Table of contents

	Page
1. General Description	1- 0
2. 3503E / 3505E Application (16+16DI)	2- 0
3. 3504E / 3564 Application (32DI)	3- 0
4. 3511 Application (In preparation)	4- 0
5. 3604E / 3624 Application (16DO).....	5- 0
6. 3664 Application (16+16DO).....	6- 0
7. 3703E Application (16AI).....	7- 0
8. 3700 / 3700A / 3701 / 3721 Application (16+16AI).....	8- 0
9. 3704E / 3720 Application (32+32AI).....	9- 0
10. 3805E Application (8AO).....	10- 0
11. Cabinet assembly	11- 0
12. Accessories	12- 0
13. Test certificate	13- 0

1. General Description

	Page
Motherboard for 16 modules	1- 1
Motherboard for 8 modules	1- 2
Installation instructions	1- 3
Power supply block diagram	1- 4
ELCO connector.....	1- 5
ISTA with Galvanic Isolated Modules List index.....	1- 6

email: sales@cambia.it

The standard motherboard is designed for 8 or 16KF modules Power feed and system connector to DCS are integrated in the motherboard, which results in noticeable space savings in the interface cabinet. The power source has a redundant design, increasing the reliability of the system. The operating status of the power supply is monitored and reported via led and relay output.

The KF modules are interfaced to the motherboard himself by using 2- to 6- pin coded cable connectors.(FSY...) The motherboard configuration is mounted on a stable metal plate. There are two brackets, on the back for mounting the board quickly and easily to a standard DIN rail in accordance with DIN EN 50022 or similar.

1. Model with 16 modules

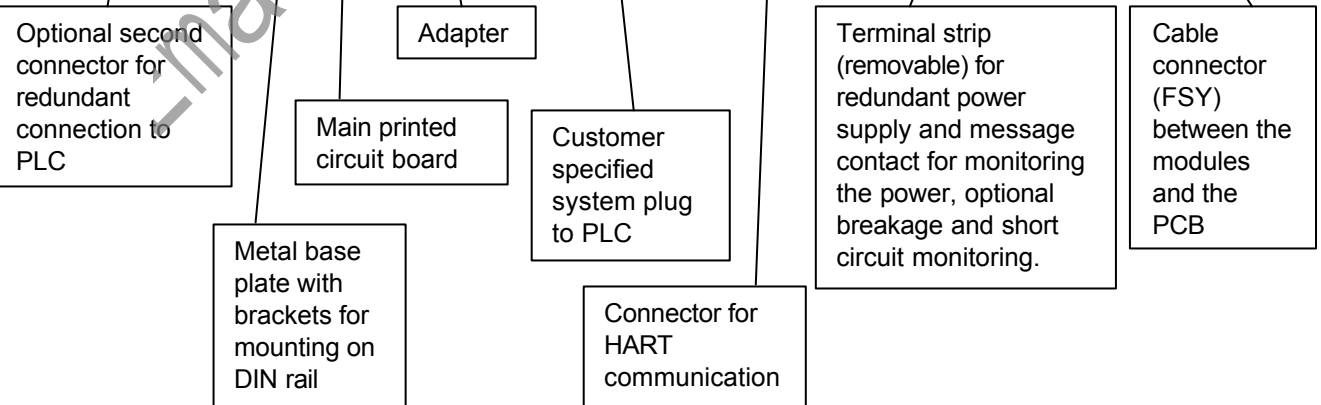
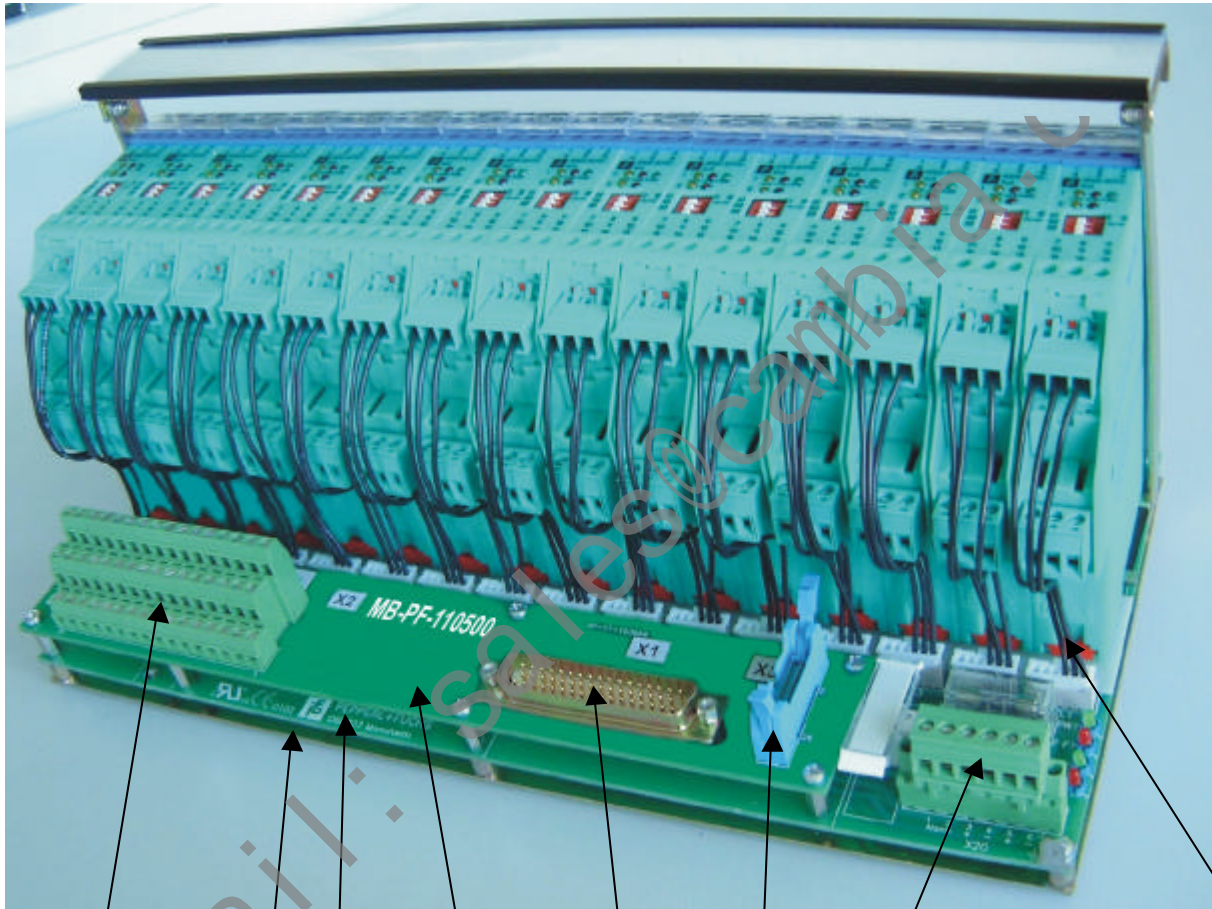

Urheberrechtlich geschützt nach DIN 34
Weitergabe sowie Vervielfältigung ist nicht gestattet

	PEPPERL+FUCHS Mannheim-Schönau		Motherboard for 16 Modules <u>General description</u>			23.02.01			vB		
						Datum	S	TZ	Sach- bearb.	gepr. techn.	gepr. Norrr
						Abt.: PA-VP			Word		
						XXXXXX			Ersatz für :		Blatt 1
			Maßstab:		von 2						

2. Model with 8 modules

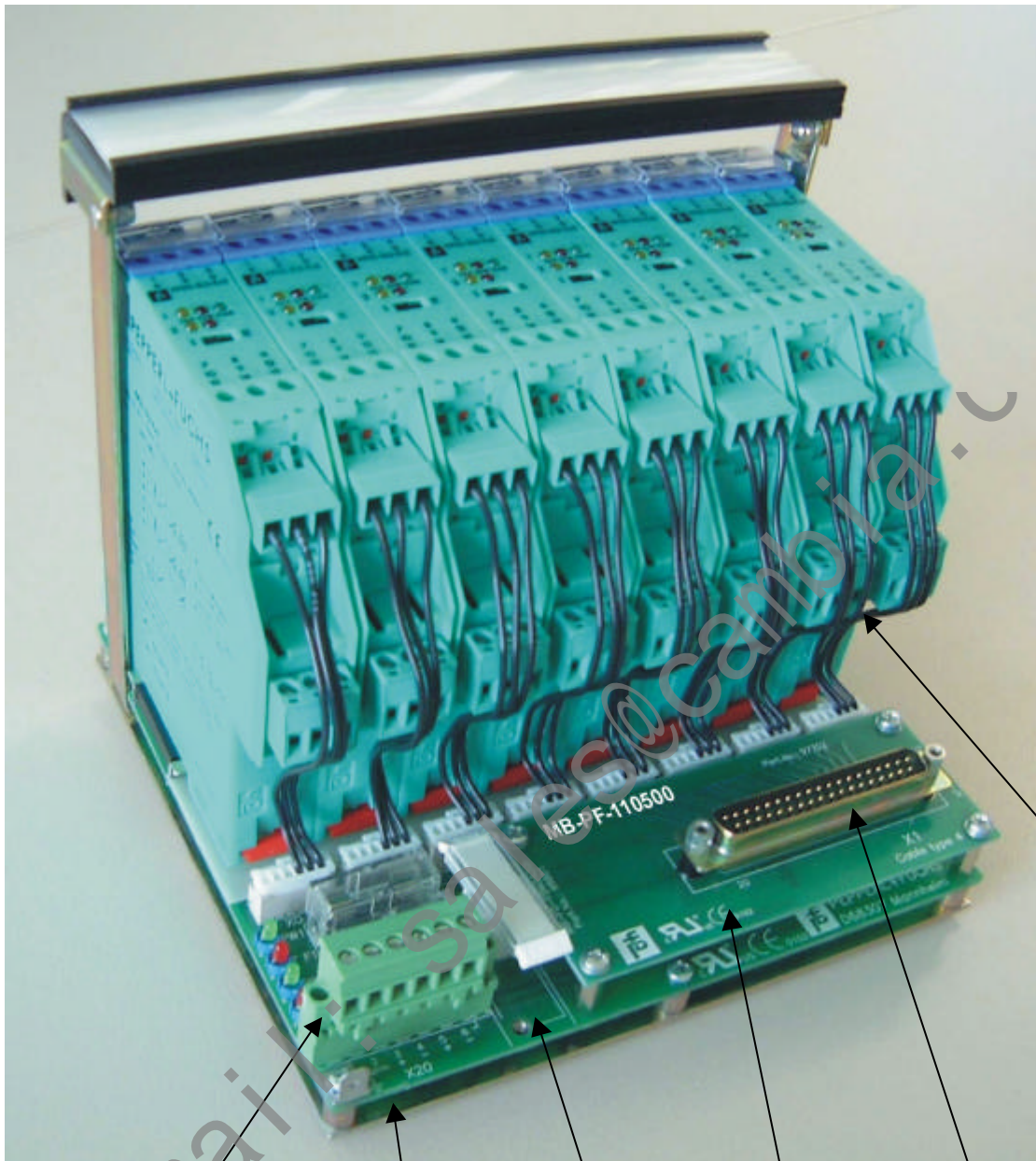

Terminal strip (removable) for redundant power supply and message contact for monitoring the power, optional breakage and short circuit monitoring.

Metal base plate with brackets for mounting on DIN rail

Main printed circuit board

Adapter

Customer specified system plug to PLC

Cable connector (FSY) between the modules and the PCB

06.02.02			KT		
Datum	S	TZ	Sachbearb.	gepr. techn.	gepr. Norm
Abt.: PA-VP			Word		
Part.Nr.:		Ersatz für :		Blatt 2	
xxxxxx		Maßstab:		von 2	

Installations instructions

1. Take away first and last module.
Operate the screw to fix the board on to the DIN rail.

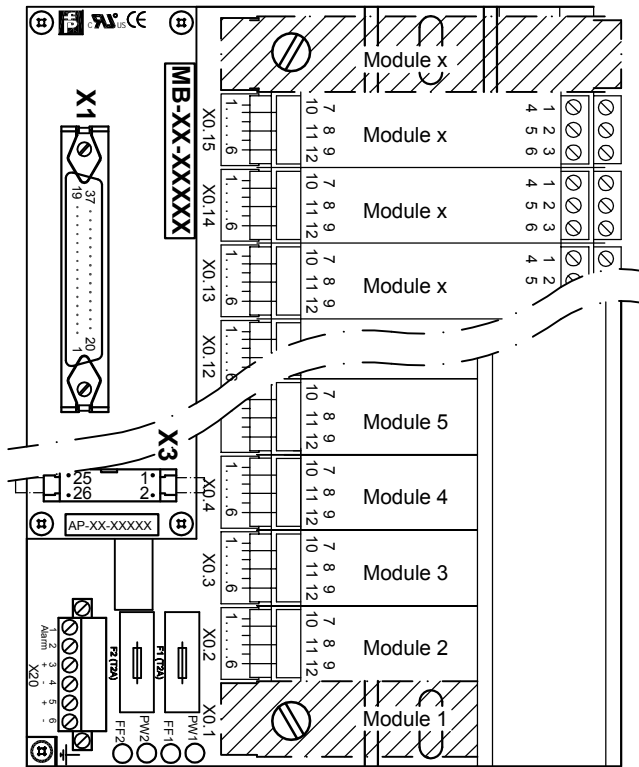

2. Turn the part as shown the stopper!

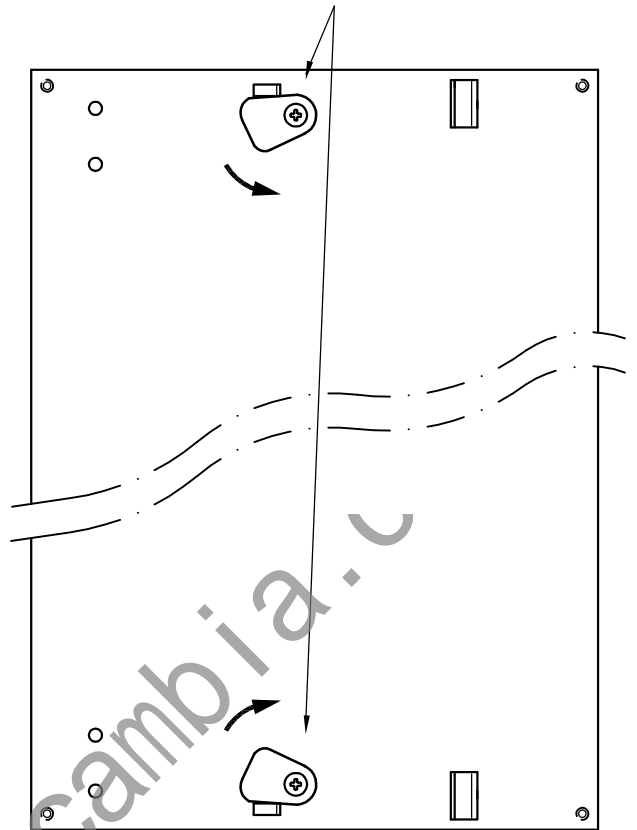

3. Set the board on the DIN rail. Turn the screw as shown till the board is fixed.
(Arrows are showing direction how to turn for fixing the board)

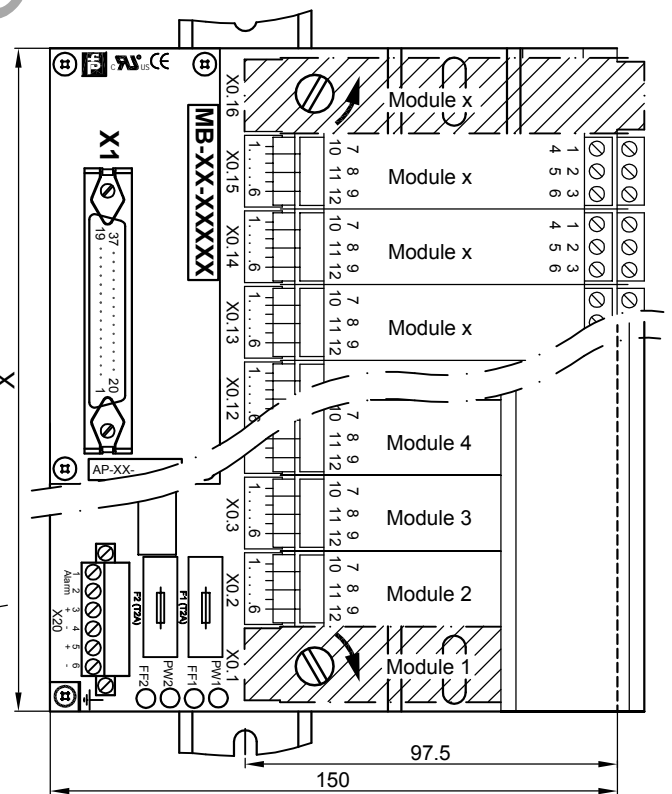
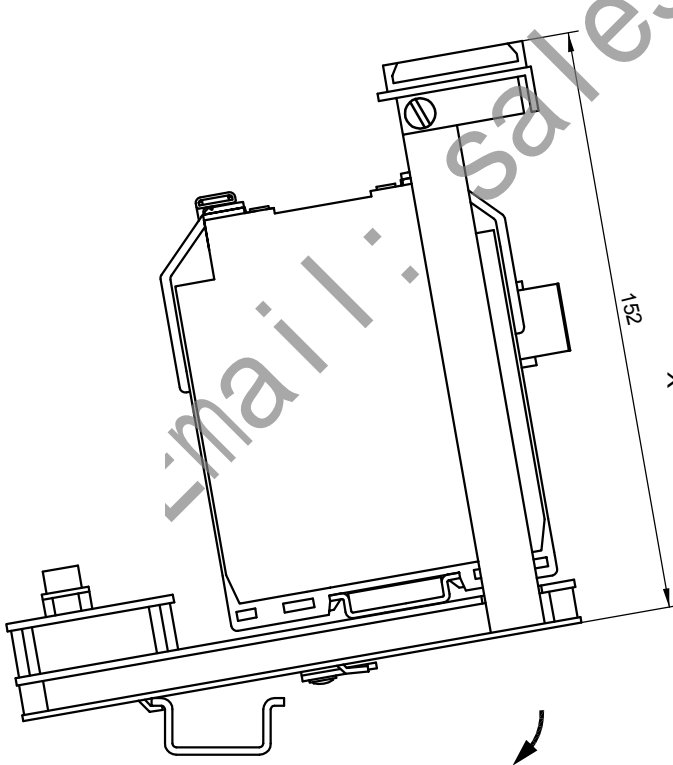

copyright according to DIN34
unauthorized distribution and reproduction prohibited



PEPPERL+FUCHS
Mannheim-Schönau

Installations instructions
for Motherboards installed
in vertical position

07.09.01	KT	vB	Sb/vB		
Date	S	TD	Off. in ch.	contr. techn.	contr. Norm
Dept.: PA-VP		No. 36-9159A1			
Up date: 02.02.04		Replaces: xxxxxx / 36-xxxx		Sheet 1	
Scale: -			of 1		

Block diagram power supply and error message

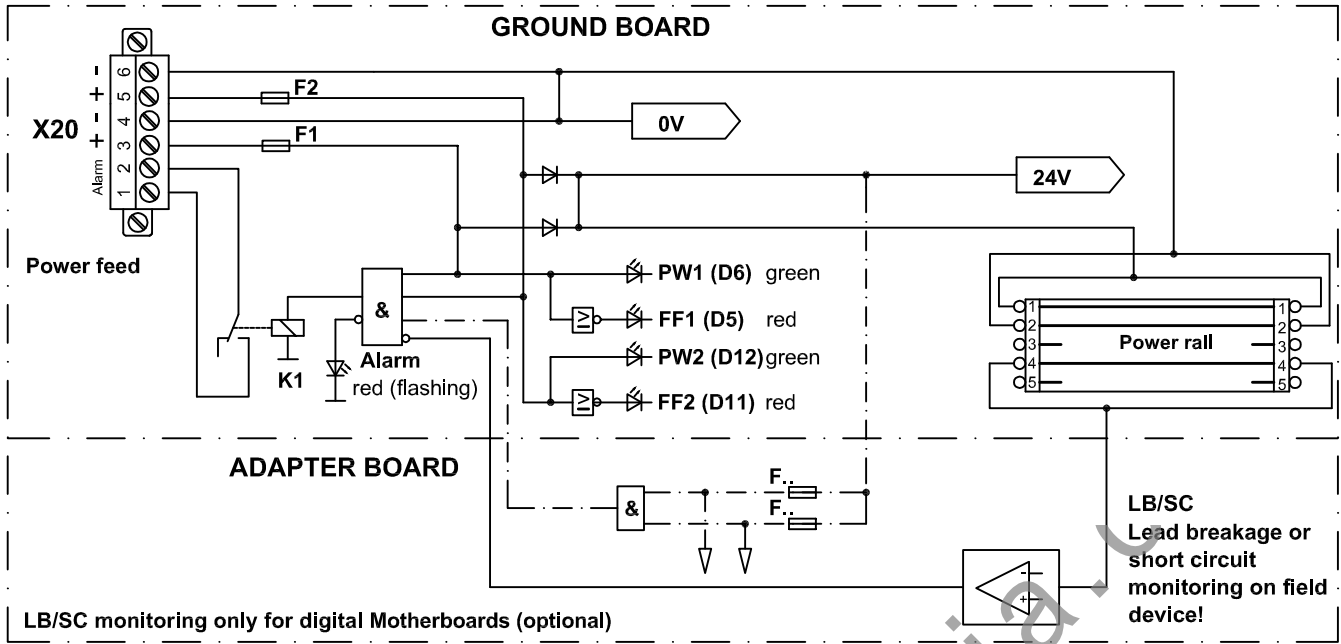

Connection power supply and error message

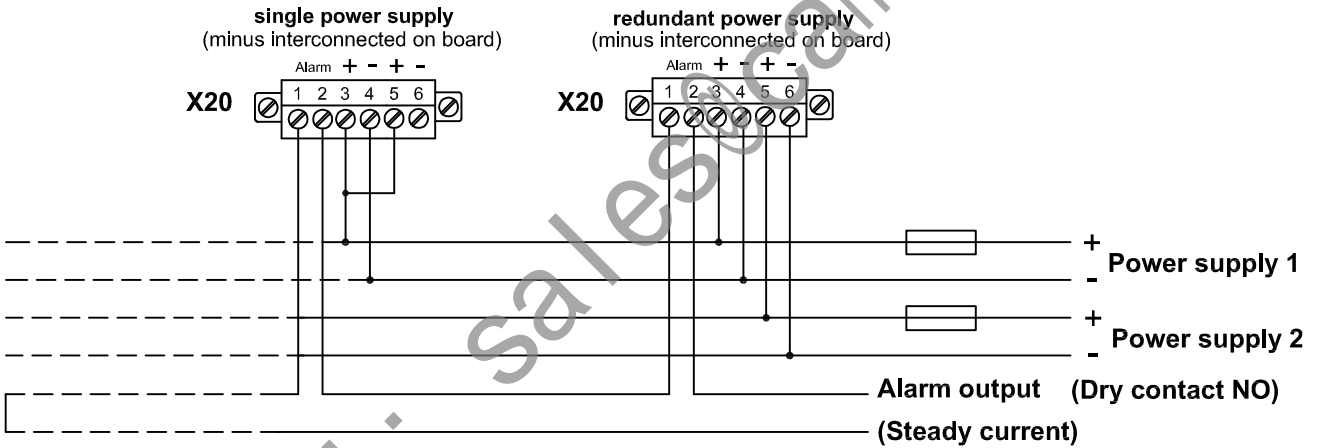

Error message and Alarm

Power supply 1	Power supply 2	LED red	LED green	X20.1, 2 Alarm contact
PS ON and Fuse 1 OK	PS ON and Fuse 2 OK	D5 OFF D11 OFF	D6 ON D12 ON	contact closed
PS ON and Fuse 1 OK	PS OFF	D5 OFF D11 ON	D6 ON D12 OFF	contact open
PS OFF	PS ON and Fuse 2 OK	D5 ON D11 OFF	D6 OFF D12 ON	contact open
PS ON and Fuse 1 OK	PS ON and Fuse 2 broken	D5 OFF D11 ON	D6 ON D12 OFF	contact open
PS ON and Fuse 1 broken	PS ON and Fuse 2 OK	D5 ON D11 OFF	D6 OFF D12 ON	contact open
PS ON and Fuse 1 broken	PS ON and Fuse 2 broken	D5 OFF D11 OFF	D6 OFF D12 OFF	contact open
PS OFF	PS OFF	D5 OFF D11 OFF	D6 OFF D12 OFF	contact open
In case of LB/SC				contact open

copyright according to DIN34 unauthorized distribution and reproduction prohibited

 PEPPERL+FUCHS Mannheim-Schönau	Block diagram Power supply monitoring Error message LB/SC MOTHERBOARD MB-4/8/12/16	04.04.01	vB	Sb	vB/Sb		
		Date	S	TZ	Off. in ch.	contr. techn.	contr. Norm
		Dept.: PA-PG-IF	Nr. 36-7143F1				
		Up date: 21.04.2010	Replaces: xxxxxxxx/ 36-xxxx	Sheet 1			
		xxxxx	Scale:	X : X	of	1	

ELCO female connector

Pin arrangement of the 56 pin ELCO connector
(female)

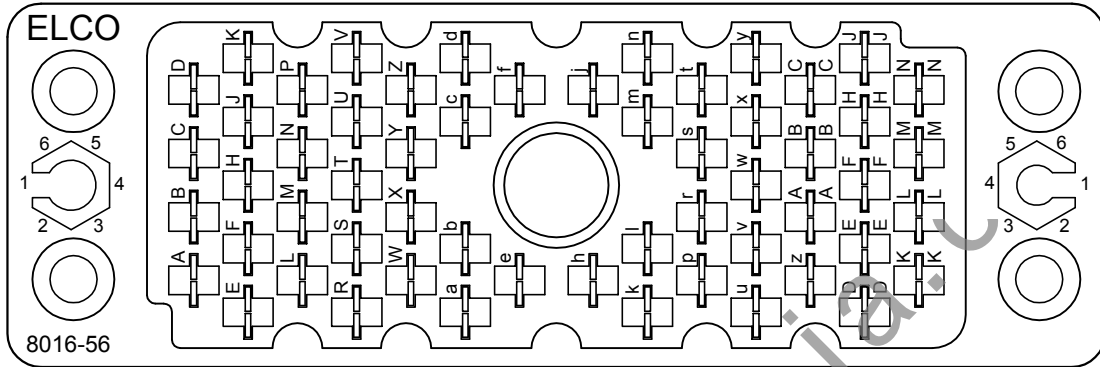

Large Key

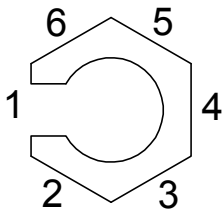

Small Key

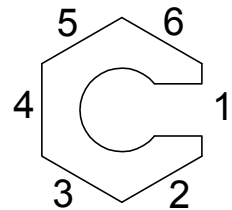

Coding for Triconex system cable

Signal	Large key position	Small key position
AI	5	1
AO	5	3
DI	3	1
DO	3	3

04.04.02		KT	Sb	Sb	
Date	S	TZ	Off. in ch.	contr. techn.	contr. Norm.
Dept.: PA-VP			Nr. 36-9227		
Up date: vB/Bro 17.03.04		Replaces: xxxxxx / 36-xxxx		Sheet 1	
Scale: - : -				of 1	



PEPPERL+FUCHS
Mannheim-Schönau

ELCO connector
for Triconex system cable

Intrinsic Safety Termination Assemblies With Galvanic Isolators

Triconex • I/O card number • Signal type	P+F Motherboard • Order name • Part No. • Drawing No.	Description • Module • Motherboard • Dimensions
3503E / 3505E (16 + 16 DI)	<ul style="list-style-type: none"> • ISTA-TR-DI-SH-350X-118289 • Part No. 118289 • Drawing No. 36-7443 	<u>Module:</u> • type KFD2-SH-Ex1.T.OP, single channel, (DI-Fail Safe) <u>Motherboard:</u> • 16 modules (16 channels) • 1 ELCO 56 pin, female system connector • LB/SC monitoring on separate screw terminal <u>Dimensions (wxhxd) :</u> • 325x150x150 mm
	<ul style="list-style-type: none"> • ISTA-TR-DI-SRLB-350X-122110 • Part No. 122110 • Drawing No. 36-7417 	<u>Module:</u> • type KFD2-SR2-Ex1.W.LB, single channel, (DI) <u>Motherboard:</u> • 16 modules (16 channels) • 1 ELCO 56 pin, female system connector • LB/SC monitoring on separate screw terminal <u>Dimensions (wxhxd) :</u> • 325x150x150 mm
	<ul style="list-style-type: none"> • ISTA-TR-DI-SR2-350X-118271 • Part No. 118271 • Drawing No. 36-7413 	<u>Module:</u> • type KFD2-SR2-Ex2.2S, dual channel, (DI) <u>Motherboard:</u> • 16 modules (16 + 16 channels) • 2 ELCO 56 pin, female system connector <u>Dimensions (wxhxd) :</u> • 325x150x150 mm
	<ul style="list-style-type: none"> • ISTA-TR-DI-SOT2-350X-118272 • Part No. 118272 • Drawing No. 36-7169 	<u>Module:</u> • type KFD2-SOT2-Ex2, dual channel, (DI) <u>Motherboard:</u> • 16 modules (16 + 16 channels) • 2 ELCO 56 pin, female system connector <u>Dimensions (wxhxd) :</u> • 325x150x150 mm
3504E / 3564 (32 + 32 DI)	<ul style="list-style-type: none"> • ISTA-TR-DI-SR2-35XX-118278 • Part No. 118278 • Drawing No. 36-7361 	<u>Module:</u> • type KFD2-SR2-Ex2.2S, dual channel, (DI) <u>Motherboard:</u> • 16 modules (32 channels) • 1 ELCO 56 pin, female system connector <u>Dimensions (wxhxd) :</u> • 325x150x150 mm
	<ul style="list-style-type: none"> • ISTA-TR-DI-SOT2-35XX-118279 • Part No. 118279 • Drawing No. 36-7188 	<u>Module:</u> • type KFD2-SOT2-Ex2, dual channel, (DI) <u>Motherboard:</u> • 16 modules (32 channels) • 1 ELCO 56 pin, female system connector <u>Dimensions (wxhxd) :</u> • 325x150x150 mm
3511 (16 DI)	<ul style="list-style-type: none"> • ISTA-TR-DI-SOT-3511-183387 • Part No. 183387 • Drawing No. 36-7697 	<u>Module:</u> • type KFD2-SOT2-Ex1.LW, single channel, (DI) <u>Motherboard:</u> • 8 modules (16 channels) • 1 ELCO 56 pin, female system connector <u>Dimensions (wxhxd) :</u> • 165x150x150 mm
3604E 3624 (16 DO)	<ul style="list-style-type: none"> • ISTA-TR-DO-SD-36XX-118274 • Part No. 118274 • Drawing No. 36-7430 	<u>Module:</u> • type KFD2-SD-Ex1.48..., single channel, (DO) <u>Motherboard:</u> • 16 modules (16 channels) • 1 ELCO 56 pin, female system connector <u>Dimensions (wxhxd) :</u> • 325x150x150 mm
	<ul style="list-style-type: none"> • ISTA-TR-DO-SL2-36XX-118273 • Part No. 118273 • Drawing No. 36-7363 	<u>Module:</u> • type KFD2-SL2-Ex2.B, dual channel, (DO) <u>Motherboard:</u> • 8 modules (16 channels) • 1 ELCO 56 pin, female system connector <u>Dimensions (wxhxd) :</u> • 165x150x150 mm
	<ul style="list-style-type: none"> • ISTA-TR-DO-SL2-36XX-118288 • Part No. 118288 • Drawing No. 36-7358 	<u>Module:</u> • type KFD2-SL2-Ex2.B, dual channel, (DO) <u>Motherboard:</u> • 8 modules (16 channels) • 1 ELCO 56 pin, female system connector • LB/SC monitoring <u>Dimensions (wxhxd) :</u> • 165x150x150 mm
3664 (16 + 16 DO)	<ul style="list-style-type: none"> • ISTA-TR-DO-SD-36XX-118274 • Part No. 118274 • Drawing No. 36-7430 	<u>Module:</u> • type KFD2-SD-Ex1.48..., single channel, (DO) <u>Motherboard:</u> • 16 modules (16 channels) • 1 ELCO 56 pin, female system connector <u>Dimensions (wxhxd) :</u> • 325x150x150 mm

Intrinsic Safety Termination Assemblies With Galvanic Isolators

Triconex • I/O card number • Signal type	P+F Motherboard • Order name • Part No. • Drawing No.	Description • Module • Motherboard • Dimensions
	<ul style="list-style-type: none"> • ISTA-TR-DO-SL2-36XX-118273 • Part No. 118273 • Drawing No. 36-7363 	<u>Module:</u> • type KFD2-SL2-Ex2.B, dual channel, (DO) <u>Motherboard:</u> • 8 modules (16 channels) • 1 ELCO 56 pin, female system connector <u>Dimensions (wxhxd):</u> • 165x150x150 mm
	<ul style="list-style-type: none"> • ISTA-TR-DO-SL2-36XX-118288 • Part No. 118288 • Drawing No. 36-7358 	<u>Module:</u> • type KFD2-SL2-Ex2.B, dual channel, (DO) <u>Motherboard:</u> • 8 modules (16 channels) • 1 ELCO 56 pin, female system connector • LB/SC monitoring <u>Dimensions (wxhxd):</u> • 165x150x150 mm
3703E (16 AI)	<ul style="list-style-type: none"> • ISTA-TR-AI-STC-370X-118275 • Part No. 118275 • Drawing No. 36-7463 	<u>Module:</u> • type KFD2-STC4-Ex1, single channel, (AI) <u>Motherboard:</u> • 16 modules (16 channels) • 1 ELCO 56 pin, female system connector • HART 26 pin, male connector <u>Dimensions (wxhxd):</u> • 325x150x150 mm
	<ul style="list-style-type: none"> • ISTA-TR-AI-UT-370X-118276 • Part No. 118276 • Drawing No. 36-7175 	<u>Module:</u> • type KFD2-UT-Ex1, single channel, (AI) <u>Motherboard:</u> • 16 modules (16 channels) • 1 ELCO 56 pin, female system connector <u>Dimensions (wxhxd):</u> • 325x150x150 mm
3700 / 3700A / 3701 / 3721 (16 + 16 AI)	<ul style="list-style-type: none"> • ISTA-TR-AI-STC-370X-118275 • Part No. 118275 • Drawing No. 36-7463 	<u>Module:</u> • type KFD2-STC4-Ex1, single channel, (AI) <u>Motherboard:</u> • 16 modules (16 channels) • 1 ELCO 56 pin, female system connector • HART 26 pin, male connector <u>Dimensions (wxhxd):</u> • 325x150x150 mm
	<ul style="list-style-type: none"> • ISTA-TR-AI-UT-370X-118276 • Part No. 118276 • Drawing No. 36-7175 	<u>Module:</u> • type KFD2-UT-Ex1, single channel, (AI) <u>Motherboard:</u> • 16 modules (16 channels) • 1 ELCO 56 pin, female system connector <u>Dimensions (wxhxd):</u> • 325x150x150 mm
3704E / 3720 (32 + 32 AI)	<ul style="list-style-type: none"> • ISTA-TR-AI-STC-370X-118290 • Part No. 118290 • Drawing No. 36-7468 	<u>Module:</u> • type KFD2-UT-Ex1, single channel, (AI) <u>Motherboard:</u> • 32 modules (32 channels) • 1 ELCO 56 pin, female system connector • 2 HART 26 pin, male connector <u>Dimensions (wxhxd):</u> • 650x150x150 mm
3805E (8 AO)	<ul style="list-style-type: none"> • ISTA-TR-AO-SCD-380X-118277 • Part No. 118277 • Drawing No. 36-7464 	<u>Module:</u> • type KFD2-SCD-Ex1.LK, single channel, (AO) <u>Motherboard:</u> • 8 modules (8 channels) • 1 ELCO 56 pin, female system connector • 2 HART 26 pin, male connector <u>Dimensions (wxhxd):</u> • 165x150x150 mm

2. 3503E / 3505E Application

(16 + 16 channels DI)

	Page
Simplified schematic 3503E / 3505E	2- 1
2 x Motherboard ISTA-TR-DI-SH-350X-118289	2- 3
Part No.:	118289
Function:	Digital Input
Channels:	16
System cable:	(ELCO connector)
KF- Module:	KFD2-SH-Ex1.T.OP (single channel)
Simplified schematic:	drawing no. 36-9279
Wiring Diagram:	drawing no. 36-7443
2 x Motherboard ISTA-TR-DI-SRLB-350X-122110	2- 6
Part No.:	122110
Function:	Digital Input
Channels:	16
System cable:	(ELCO connector)
KF- Module:	KFD2-SR2-Ex1.W.LB (single channel)
Simplified schematic:	drawing no. 36-9279
Wiring Diagram:	drawing no. 36-7417
Simplified schematic 3503E / 3505E	2- 9
Motherboard ISTA-TR-DI-SR2-350X-118271	2- 11
Part No.:	118271
Function:	Digital Input
Channels:	16 + 16
System cable:	(ELCO connector)
KF- Module:	KFD2-SR2-Ex2.2S (dual channel)
Simplified schematic:	drawing no. 36-9280
Wiring Diagram:	drawing no. 36-7413
Motherboard ISTA-TR-DI-SOT2-350X-118272	2- 14
Part No.:	118272
Function:	Digital Input
Channels:	16 + 16
System cable:	(ELCO connector)
KF- Module:	KFD2-SOT2-Ex2 (dual channel)
Simplified schematic:	drawing no. 36-9280
Wiring Diagram:	drawing no. 36-7169

3503E / 3505E DIGITAL INPUT MODULE (Fail safe)

Simplified schematic of a typical 32-point commoned 24 VDC digital input module with self-test (1 of 32 points shown)

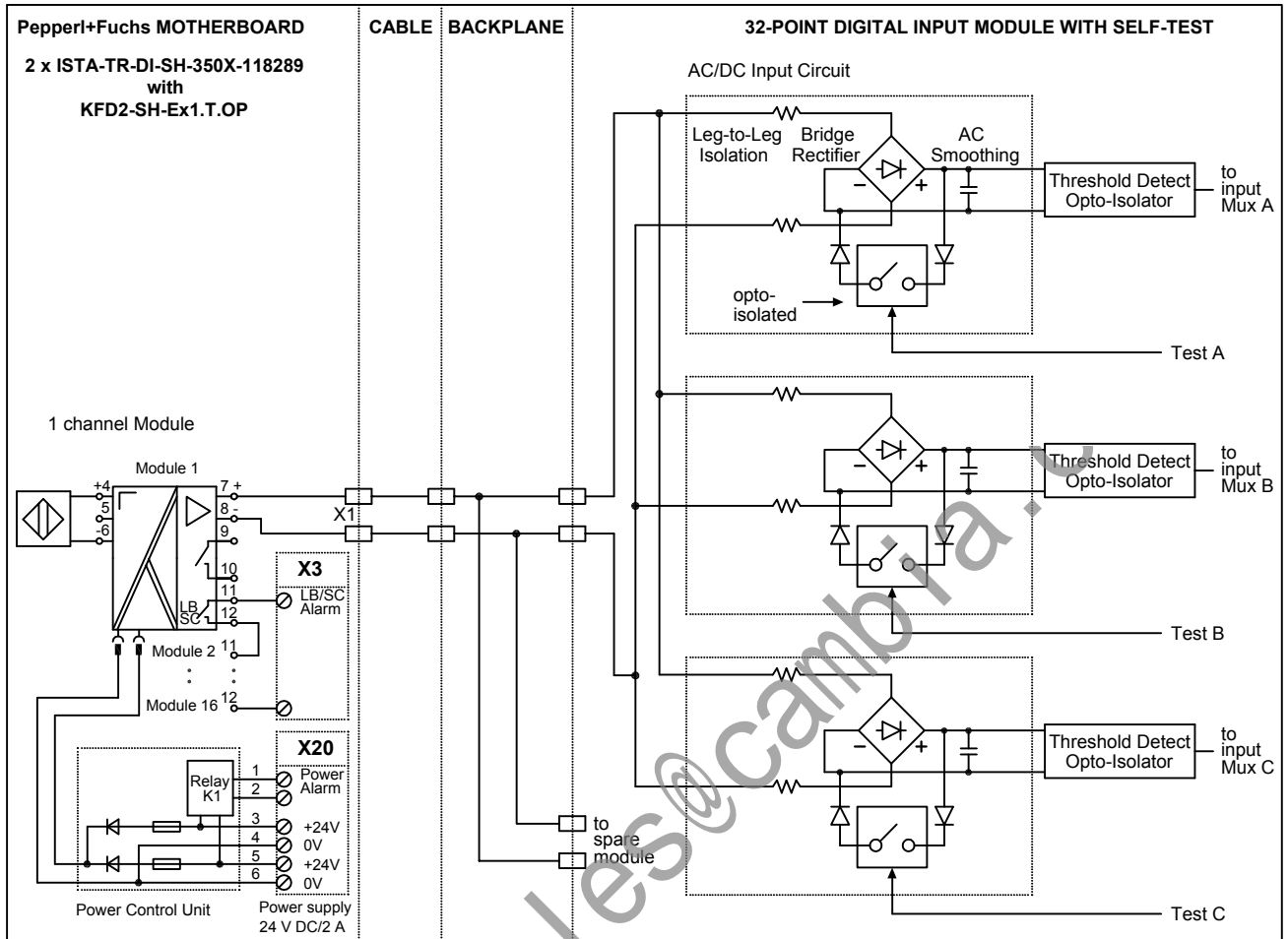

Pin assignment of connector #A (56 pin ELCO female)

Pin	AA	KK	LL	z	DD	EE	p	u	v	h	k	l	e	a
Signal	IN1+		IN1-	IN2+		IN2-	IN3+		IN3-	IN4+		IN4-	IN5+	
Pin	b	W	R	S	L	E	F	M	A	B	BB	NN	MM	CC
Signal	IN5-	IN6+		IN6-	IN7+		IN7-	IN8+		IN8-	IN9+		IN9-	IN10+
Pin	JJ	HH	t	y	x	j	n	m	f	d	c	Z	V	U
Signal		IN10-	IN11+		IN11-	IN12+		IN12-	IN13+		IN13-	IN14+		IN14-
Pin	P	K	J	N	D	C	T	H	w	FF	r	s	X	Y
Signal	IN15+		IN15-	IN16+		IN16-	CGND	CGND	CGND	CGND	**	**	**	**

Pin assignment of connector #B (56 pin ELCO female)

Pin	AA	KK	LL	z	DD	EE	p	u	v	h	k	l	e	a
Signal	IN17+		IN17-	IN18+		IN18-	IN19+		IN19-	IN20+		IN20-	IN21+	
Pin	b	W	R	S	L	E	F	M	A	B	BB	NN	MM	CC
Signal	IN21-	IN22+		IN22-	IN23+		IN23-	IN24+		IN24-	IN25+		IN25-	IN26+
Pin	JJ	HH	t	y	x	j	n	m	f	d	c	Z	V	U
Signal		IN26-	IN27+		IN27-	IN28+		IN28-	IN29+		IN29-	IN30+		IN30-
Pin	P	K	J	N	D	C	T	H	w	FF	r	s	X	Y
Signal	IN31+		IN31-	IN32+		IN32-	CGND	CGND	CGND	CGND	**	**	**	**

** not used

CGND is the chassis ground

02.03.99	AJ	AJ	--	
Date	S	TZ	Off. in ch.	contr. Norm
Dept.: PA-VP	Nr. 36-9279			
Up date: 19.03.04	Replaces: XXXXX / 36-XXXX		Sheet 1	
Scale:		- : - of 2		



PEPPERL+FUCHS
Mannheim-Schönau

D-TR-3503E / 3505E

copyright according to DIN34
unauthorized distribution and reproduction prohibited

3503E / 3505E DIGITAL INPUT MODULE (Non-Fail safe)

Simplified schematic of a typical 32-point commoned 24 VDC digital input module with self-test (1 of 32 points shown)

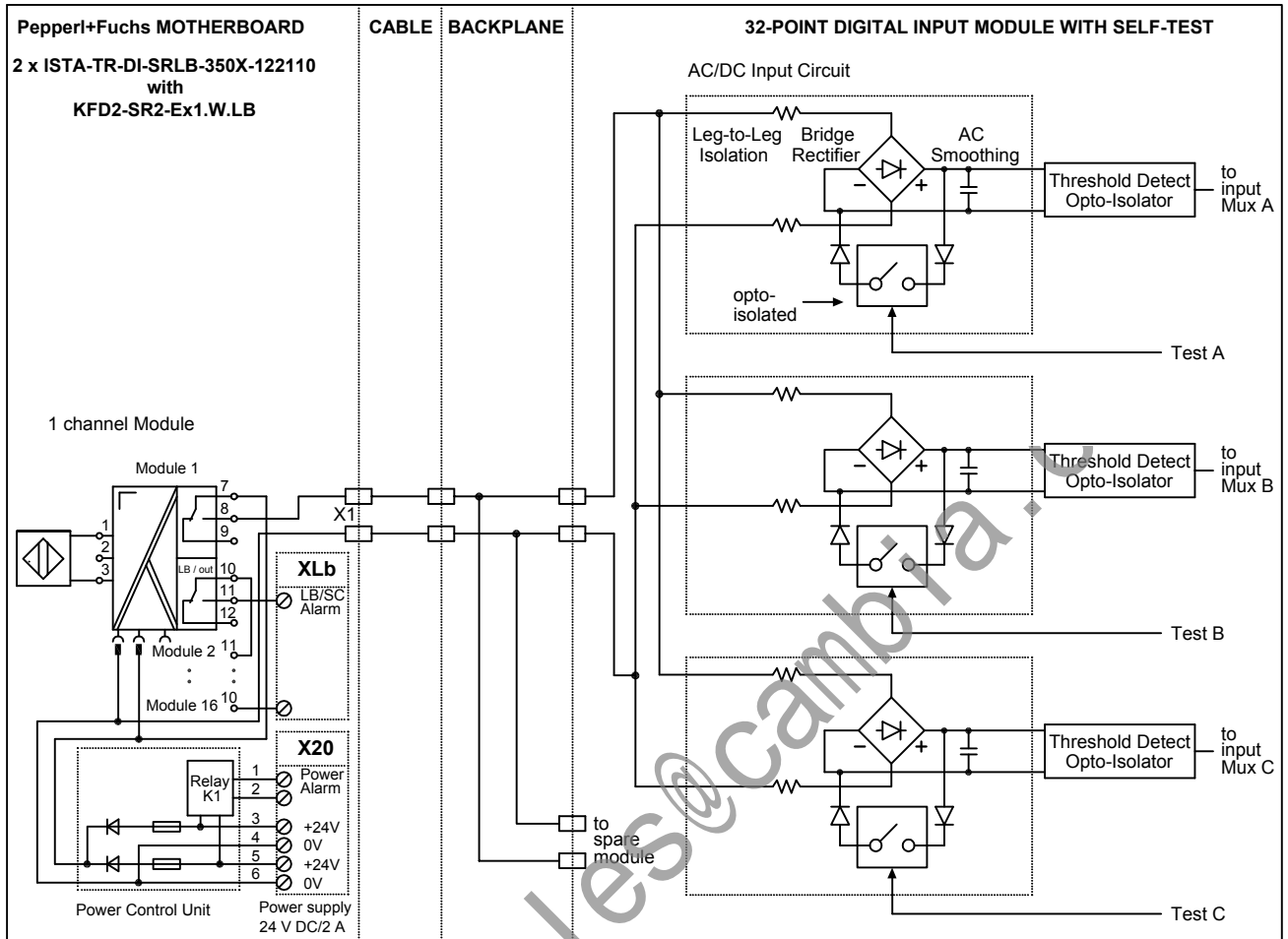

Pin assignment of connector #A (56 pin ELCO female)

Pin	AA	KK	LL	z	DD	EE	p	u	v	h	k	l	e	a
Signal	IN1+		IN1-	IN2+		IN2-	IN3+		IN3-	IN4+		IN4-	IN5+	
Pin	b	W	R	S	L	E	F	M	A	B	BB	NN	MM	CC
Signal	IN5-	IN6+		IN6-	IN7+		IN7-	IN8+		IN8-	IN9+		IN9-	IN10+
Pin	JJ	HH	t	y	x	j	n	m	f	d	c	Z	V	U
Signal		IN10-	IN11+		IN11-	IN12+		IN12-	IN13+		IN13-	IN14+		IN14-
Pin	P	K	J	N	D	C	T	H	w	FF	r	s	X	Y
Signal	IN15+		IN15-	IN16+		IN16-	CGND	CGND	CGND	CGND	**	**	**	**

Pin assignment of connector #B (56 pin ELCO female)

Pin	AA	KK	LL	z	DD	EE	p	u	v	h	k	l	e	a
Signal	IN17+		IN17-	IN18+		IN18-	IN19+		IN19-	IN20+		IN20-	IN21+	
Pin	b	W	R	S	L	E	F	M	A	B	BB	NN	MM	CC
Signal	IN21-	IN22+		IN22-	IN23+		IN23-	IN24+		IN24-	IN25+		IN25-	IN26+
Pin	JJ	HH	t	y	x	j	n	m	f	d	c	Z	V	U
Signal		IN26-	IN27+		IN27-	IN28+		IN28-	IN29+		IN29-	IN30+		IN30-
Pin	P	K	J	N	D	C	T	H	w	FF	r	s	X	Y
Signal	IN31+		IN31-	IN32+		IN32-	CGND	CGND	CGND	CGND	**	**	**	**

** not used

CGND is the chassis ground

02.03.99	AJ	AJ	--	
Date	S	TZ	Off. in ch.	contr. techn.
Dept.: PA-VP	Nr. 36-9279			
Up date: 19.03.04	AvB/Bro	Replaces: XXXXX / 36-XXXX	Sheet 2	
Scale:		- : - of 2		



D-TR-3503E / 3505E

copyright according to DIN34 unauthorized distribution and reproduction prohibited

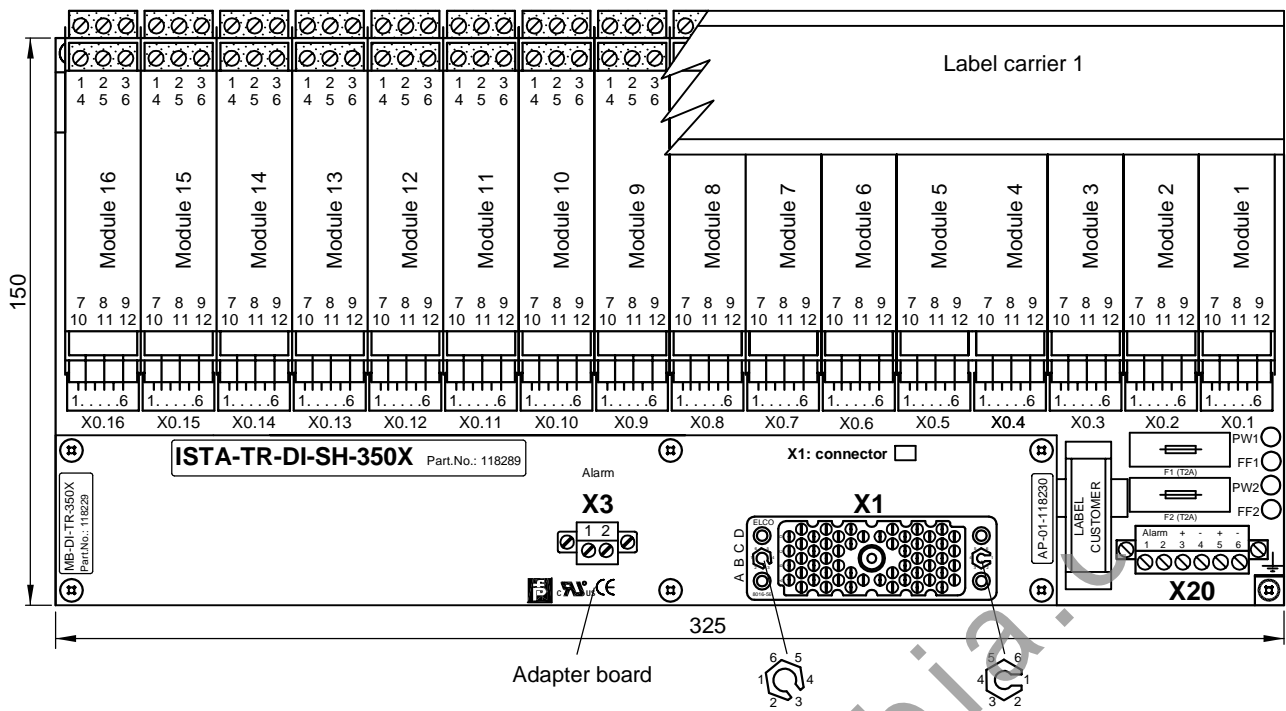

APPLICATION:

TRICONEX I/O card 3503E / 3505E (2 x ISTA-TR-DI-SH-350X-118289)
 32 points, non commoned, diff., DC coupled

Motherboard 2: connected with connector #B
 Module 1 ... 16, channels 17 ... 32

Motherboard 1: connected with connector #A
 Module 1 ... 16, channels 1 ... 16

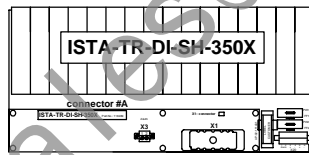
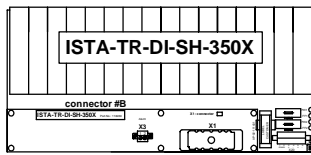

Name	Note
X1	56 pin female system connector ELCO (small key: 1, large key: 3)
X3	2 pin screw terminal
X0.1 16	6 pin male terminals for cable tree FSY....
X20.3 6	Power supply screw terminals
X20.1, X20.2	Alarm screw terminal
F1, F2	Fuse
PW1, PW2, FF1, FF2	LEDs for power and power failure

Ordering information: ISTA-TR-DI-SH-350X-118289

Basic components:	Description
16 pieces: KFD2-SH-Ex1.T.OP (DI/FS)	KF-Module type (function)
1 piece: MB-DI-TR-350X-118229	Motherboard without modules
composed by:	
1 piece: MB-16U5L-103681	Motherboard without modules, adapter board, FSY cable tree and Label carrier
1 piece: AP-01-118230	Adapter board
1 piece: KFD0-LC1-16M-99144	Label carrier 1
16 pieces: FSY-K023L540-118266	Cable tree connection KF-Module-Motherboard

copyright according to DIN34
 unauthorized distribution and reproduction prohibited

	Motherboard unit Digital Input (Fail Safe) 16 channels - LB/SC monitoring ISTA-TR-DI-SH-350X	03.04.02	KT	Sb	Sb	
		Date	S TZ	Off. in ch.	contr. techn.	contr. Norm
		Dept.: PA-VP	Nr. 36-7443A			
		vB/Bro	Replaces:			
Up date: 30.03.05		xxxx / 36-xxxx			Sheet 1	
MB-16U5L		Scale: 1 : 2 (1 : 8)			of 3	

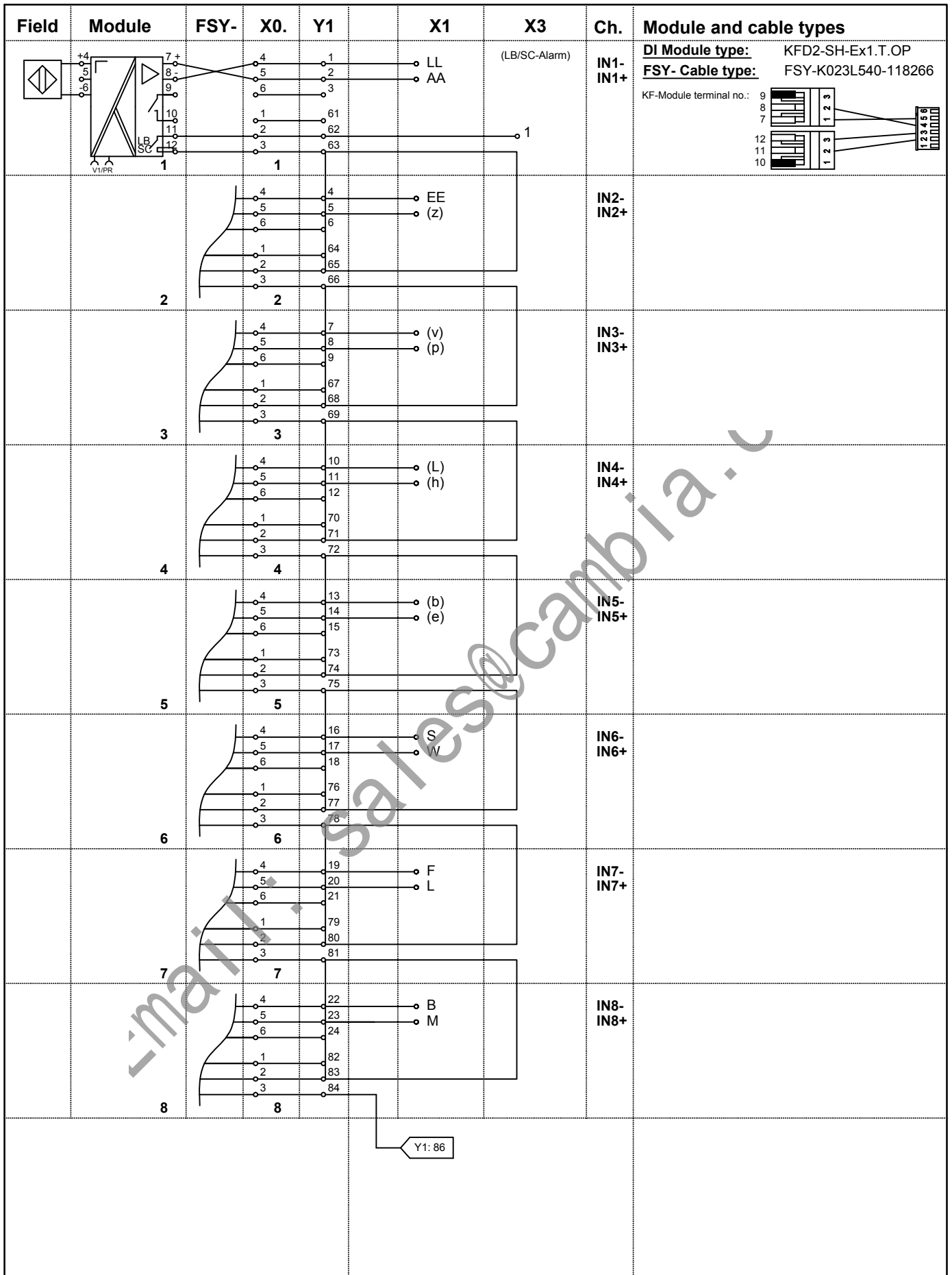

copyright according to DIN34
 unauthorized distribution and reproduction prohibited

PEPPERL+FUCHS Mannheim-Schönau	Motherboard unit Digital Input (Fail Safe) 16 channels - LB/SC monitoring ISTA-TR-DI-SH-350X		03.04.02		KT	Sb	Sb/vB	
	Date	S	TZ	Off. in ch.	contr. techn.	contr. Norm		
	Dept.:	PA-VP		Nr. 36-7443A				
	Up date:	vB/Bro 18.03.04		Replaces:	xxxx / 36-xxxx	Sheet 2		
	MB-16U5L		Scale:	- : -	of	3		

Field	Module	FSY-	X0.	Y1	X1	X3	Ch.
	9	Y1: 84	4, 5, 6, 1, 2, 3	25, 26, 27, 85, 86, 87	MM, BB	(LB/SC-Alarm)	IN9- IN9+
	10		4, 5, 6, 1, 2, 3	28, 29, 30, 88, 89, 90	HH, CC		IN10- IN10+
	11		4, 5, 6, 1, 2, 3	31, 32, 33, 91, 92, 93	(x), (t)		IN11- IN11+
	12		4, 5, 6, 1, 2, 3	34, 35, 36, 94, 95, 96	(m), (j)		IN12- IN12+
	13		4, 5, 6, 1, 2, 3	37, 38, 39, 97, 98, 99	(c), (f)		IN13- IN13+
	14		4, 5, 6, 1, 2, 3	40, 41, 42, 100, 101, 102	U, Z		IN14- IN14+
	15		4, 5, 6, 1, 2, 3	43, 44, 45, 103, 104, 105	J, P		IN15- IN15+
	16		4, 5, 6, 1, 2, 3	46, 47, 48, 106, 107, 108	C, N		IN16- IN16+
			(+ 24VDC) X20: 3,5	49 ... 51			
			(0V) X20: 4,6	52 ... 54			
			Ground metal mounting plate	55			
			V1	56			
			V2	57			
			LB/SC	58			
			PF1	59			
			PF2	60			
							<p>Loop for channel 1</p>

copyright according to DIN34
unauthorized distribution and reproduction prohibited

	Motherboard unit Digital Input (Fail Safe) 16 channels - LB/SC monitoring ISTA-TR-DI-SH-350X		03.04.02	KT	Sb	Sb/vB	
	Date	S TZ	Off. in ch.	contr. techn.	contr. Norm		
	Dept.: PA-VP	vB/Bro	Nr. 36-7443A		Replaces:		Sheet 3
	Up date: 18.03.04		xxxx / 36-xxxx				
MB-16U5L	Scale:	- : -				of 3	

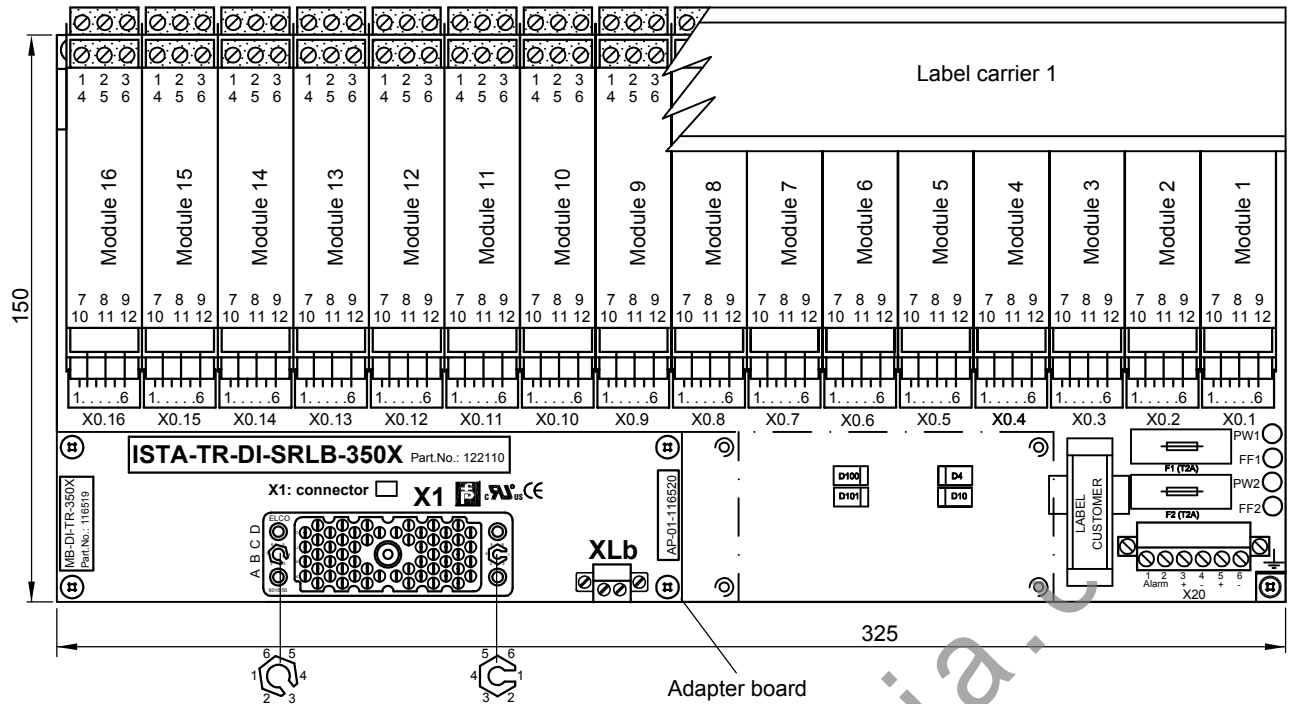

APPLICATION:

TRICONEX I/O card 3503E / 3505E: will be required 2 x ISTA-TR-DI-SRLB-350X-122110
32 points, commoned in groups of 8

Motherboard: connected with connector #B
Module 1 ... 16, channels 17 ... 32

connected with connector #A
Module 1 ... 16, channels 1 ... 16

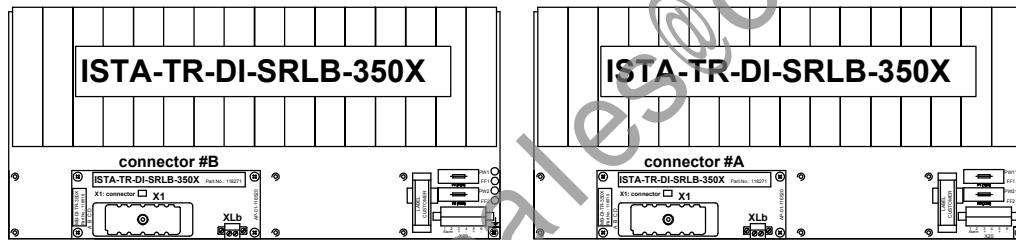

Name	Note
X1	56 pin female system connector ELCO (small key: 1, large key: 3)
XLb	2 pin screw terminals
X0.1 16	6 pin male terminals for cable tree FSY....
X20.3 6	Power supply screw terminals
X20.1, X20.2	Alarm screw terminal
F1, F2	Fuse
PW1, PW2, FF1, FF2	LEDs for power and power failure

Ordering information: ISTA-TR-DI-SRLB-350X-122110

Basic components:	Description
16 pieces: KFD2-SR2-Ex1.W.LB (DI)	KF-Module type (function)
1 piece: MB-DI-TR-350X-116519	Motherboard without modules
composed by:	
1 piece: MB-16U5L-103681	Motherboard without modules, adapter board, FSY cable tree and Label carrier
1 piece: AP-01-116520	Adapter board
1 piece: KFD0-LC1-16M-99144	Label carrier 1
16 pieces: FSY-K120L450-Y98836	Cable tree connection KF-Module-Motherboard

08.11.01	KT	Sb	Sb	
Date	S TZ	Off. in ch.	contr. techn.	contr. Norm
Dept.: PA-VP	Nr. 36-7417			
Up date: 18.03.04	Replaces: vB/Bro	Y95447 / 36-7021	Sheet 1	
MB-16U5L	Scale: 1 : 2 (1 : 5)	of 3		



PEPPERL+FUCHS
Mannheim-Schönau

Motherboard unit
Digital Input
16 channels, LB/SC monitoring
ISTA-TR-DI-SRLB-350X

copyright according to DIN34
 unauthorized distribution and reproduction prohibited

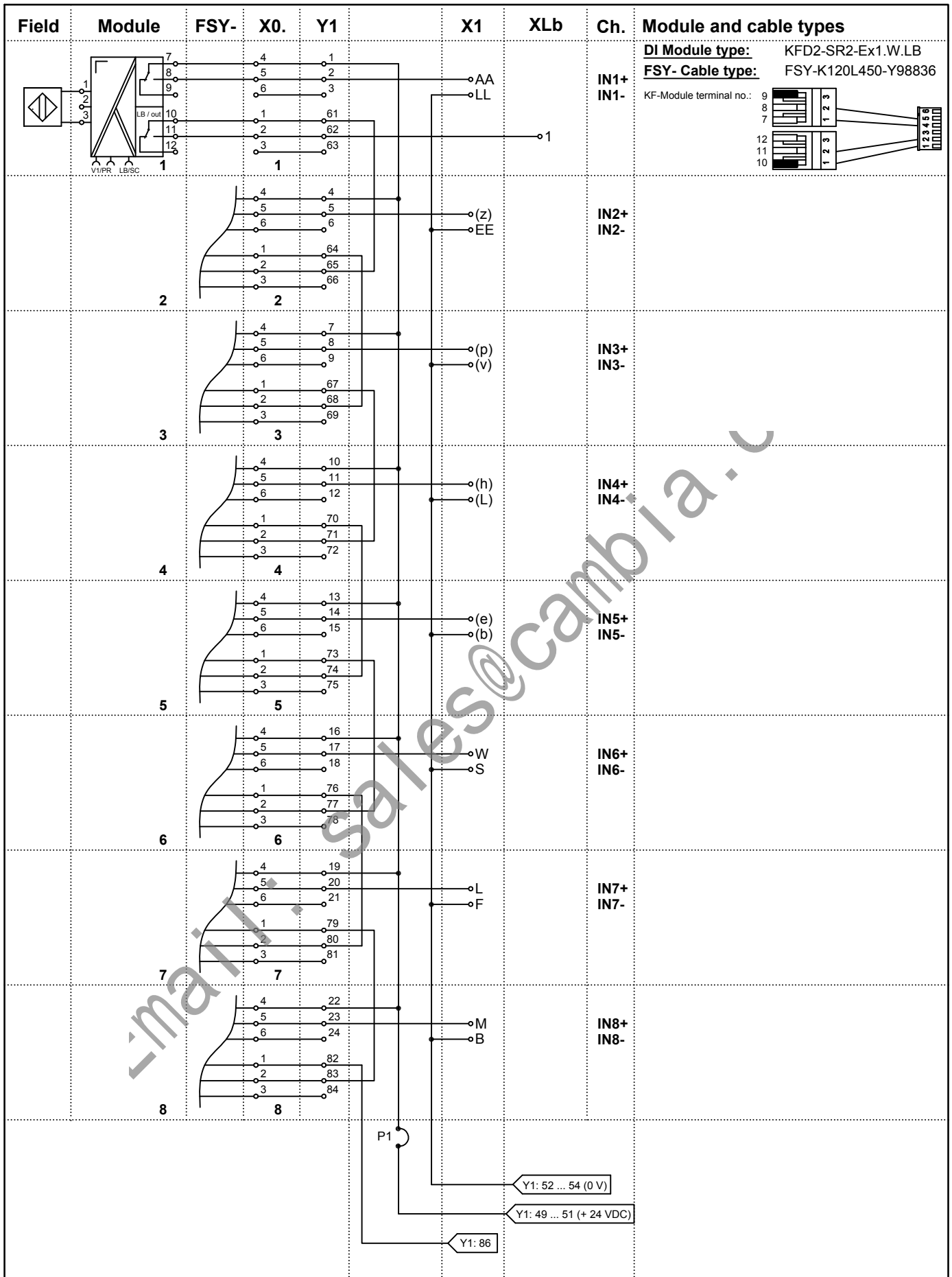

P1 = link (0 Ohm resistors)

Note: Letters in brackets are small letters

06.11.01		KT	vB	vB/Sb	
Date	S	TZ	Off. in ch.	contr. techn.	contr. Norm
Dept.: PA-VP			Nr. 36-7417		
Up date: 18.03.04			Replaces: Y95447 / 36-7021		
MB-16U5L			Scale:		
					Sheet 2 of 3



PEPPERL+FUCHS
 Mannheim-Schönau

Motherboard unit
 Digital Input
 16 channels, LB/SC monitoring
 ISTA-TR-DI-SRLB-350X

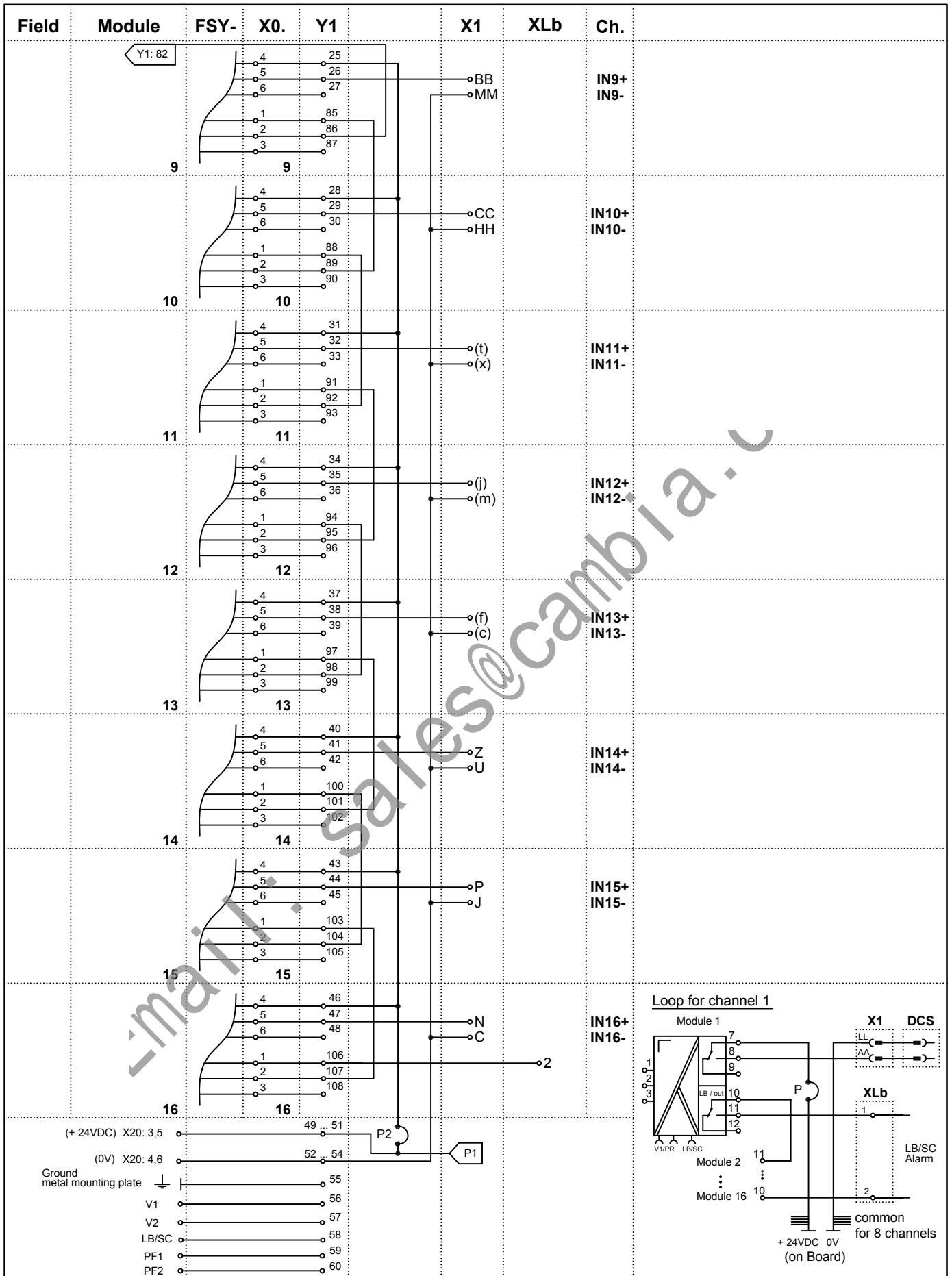

P2 = link (0 Ohm resistors)
Note: Letters in brackets are small letters

08.11.01		KT	vB	vB/Sb	
Date	S	TZ	Off. in ch.	contr. techn.	contr. Norm
Dept.: PA-VP	Nr. 36-7417				
Up date: 18.03.04	vB/Bro		Replaces: Y95447 / 36-7021		Sheet 3
MB-16U5L	Scale:		of 3		



PEPPERL+FUCHS
Mannheim-Schönau

Motherboard unit
Digital Input
16 channels, LB/SC monitoring
ISTA-TR-DI-SRLB-350X

3503E / 3505E DIGITAL INPUT MODULE

Simplified schematic of a typical 32-point commoned 24 VDC digital input module with self-test (1 of 32 points shown)

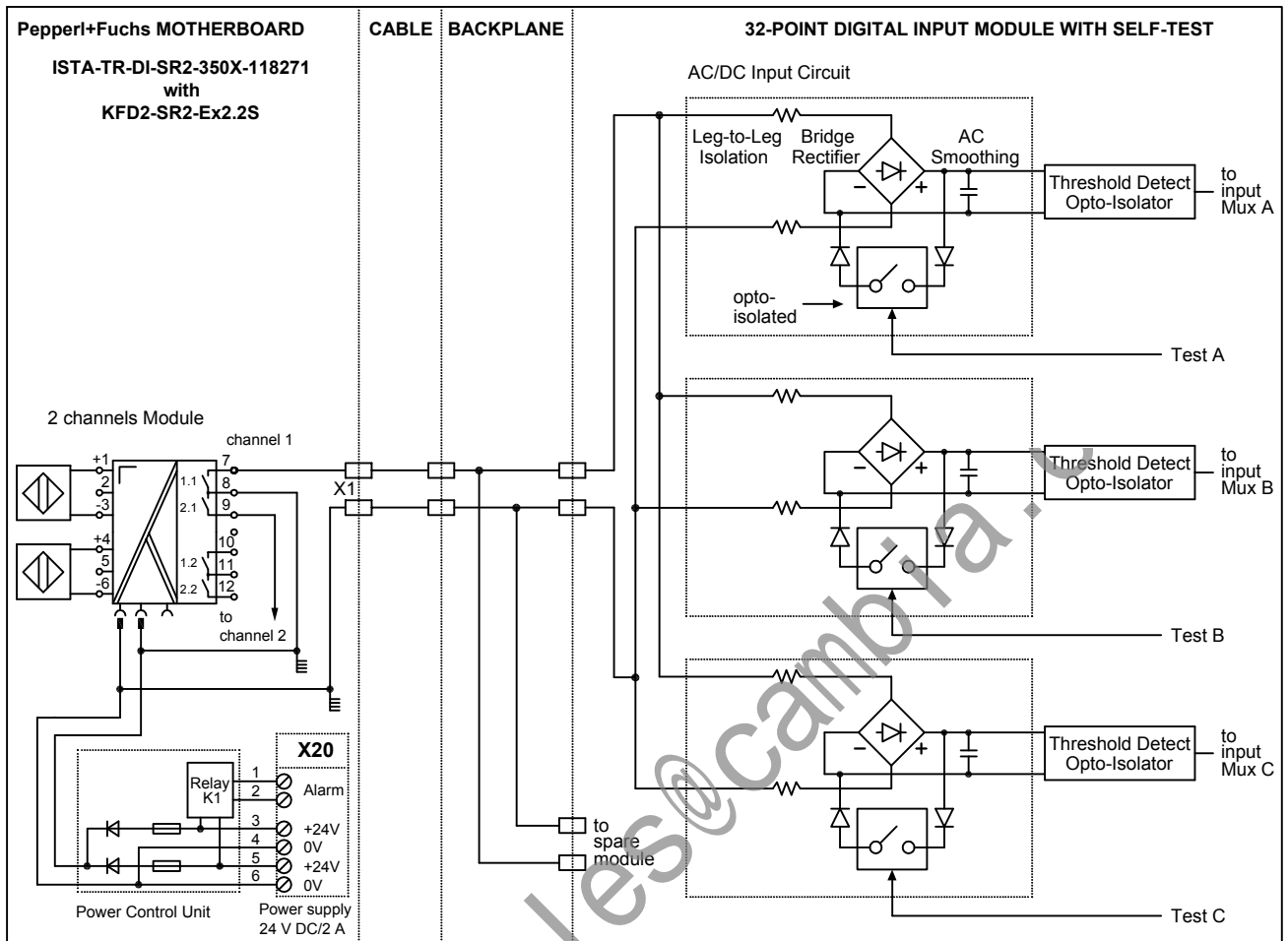

Pin assignment of connector #1 (56 pin ELCO female)

Pin	AA	KK	LL	z	DD	EE	p	u	v	h	k	l	e	a
Signal	IN1+		IN1-	IN2+		IN2-	IN3+		IN3-	IN4+		IN4-	IN5+	
Pin	b	W	R	S	L	E	F	M	A	B	BB	NN	MM	CC
Signal	IN5-	IN6+		IN6-	IN7+		IN7-	IN8+		IN8-	IN9+		IN9-	IN10+
Pin	JJ	HH	t	y	x	j	n	m	f	d	c	Z	V	U
Signal		IN10-	IN11+		IN11-	IN12+		IN12-	IN13+		IN13-	IN14+		IN14-
Pin	P	K	J	N	D	C	T	H	w	FF	r	s	X	Y
Signal	IN15+		IN15-	IN16+		IN16-	CGND	CGND	CGND	CGND	**	**	**	**

Pin assignment of connector #2 (56 pin ELCO female)

Pin	AA	KK	LL	z	DD	EE	p	u	v	h	k	l	e	a
Signal	IN17+		IN17-	IN18+		IN18-	IN19+		IN19-	IN20+		IN20-	IN21+	
Pin	b	W	R	S	L	E	F	M	A	B	BB	NN	MM	CC
Signal	IN21-	IN22+		IN22-	IN23+		IN23-	IN24+		IN24-	IN25+		IN25-	IN26+
Pin	JJ	HH	t	y	x	j	n	m	f	d	c	Z	V	U
Signal		IN26-	IN27+		IN27-	IN28+		IN28-	IN29+		IN29-	IN30+		IN30-
Pin	P	K	J	N	D	C	T	H	w	FF	r	s	X	Y
Signal	IN31+		IN31-	IN32+		IN32-	CGND	CGND	CGND	CGND	**	**	**	**

** not used

CGND is the chassis ground

02.03.99	AJ	AJ	--	
Date	S	TZ	Off. in ch.	contr. techn.
Dept.: PA-VP	Nr. 36-9280			
Up date: 19.03.04	Replaces: XXXXX / 36-XXXX			Sheet 1
Scale: - : -			of 2	



PEPPERL+FUCHS
Mannheim-Schönau

D-TR-3503E / 3505E

copyright according to DIN34
unauthorized distribution and reproduction prohibited

3503E / 3505E DIGITAL INPUT MODULE

Simplified schematic of a typical 32-point commoned 24 VDC digital input module with self-test (1 of 32 points shown)

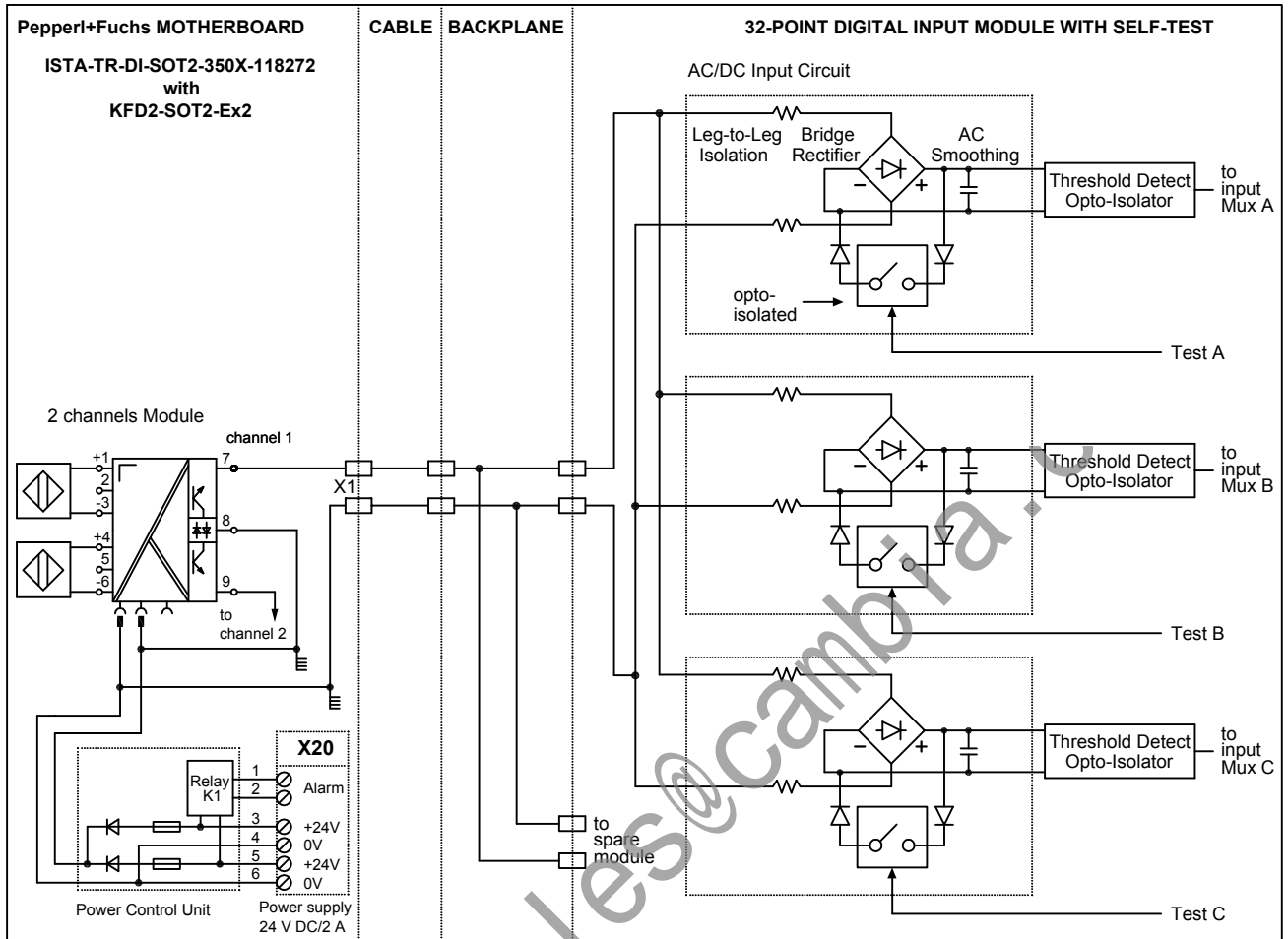

Pin assignment of connector #1 (56 pin ELCO female)

Pin	AA	KK	LL	z	DD	EE	p	u	v	h	k	l	e	a
Signal	IN1+		IN1-	IN2+		IN2-	IN3+		IN3-	IN4+		IN4-	IN5+	
Pin	b	W	R	S	L	E	F	M	A	B	BB	NN	MM	CC
Signal	IN5-	IN6+		IN6-	IN7+		IN7-	IN8+		IN8-	IN9+		IN9-	IN10+
Pin	JJ	HH	t	y	x	j	n	m	f	d	c	Z	V	U
Signal		IN10-	IN11+		IN11-	IN12+		IN12-	IN13+		IN13-	IN14+		IN14-
Pin	P	K	J	N	D	C	T	H	w	FF	r	s	X	Y
Signal	IN15+		IN15-	IN16+		IN16-	CGND	CGND	CGND	CGND	**	**	**	**

Pin assignment of connector #2 (56 pin ELCO female)

Pin	AA	KK	LL	z	DD	EE	p	u	v	h	k	l	e	a
Signal	IN17+		IN17-	IN18+		IN18-	IN19+		IN19-	IN20+		IN20-	IN21+	
Pin	b	W	R	S	L	E	F	M	A	B	BB	NN	MM	CC
Signal	IN21-	IN22+		IN22-	IN23+		IN23-	IN24+		IN24-	IN25+		IN25-	IN26+
Pin	JJ	HH	t	y	x	j	n	m	f	d	c	Z	V	U
Signal		IN26-	IN27+		IN27-	IN28+		IN28-	IN29+		IN29-	IN30+		IN30-
Pin	P	K	J	N	D	C	T	H	w	FF	r	s	X	Y
Signal	IN31+		IN31-	IN32+		IN32-	CGND	CGND	CGND	CGND	**	**	**	**

** not used	CGND is the chassis ground	02.03.99	AJ	AJ	--		
		Date	S	TZ	Off. in ch.	contr. Norm	
 PEPPERL+FUCHS Mannheim-Schönau	D-TR-3503E / 3505E	Dept.: PA-VP	Nr. 36-9280				
		Up date: 19.03.04	Replaces: XXXXX / 36-XXXX	Sheet 2			
		Scale: - : -	of 2				

copyright according to DIN34 unauthorized distribution and reproduction prohibited

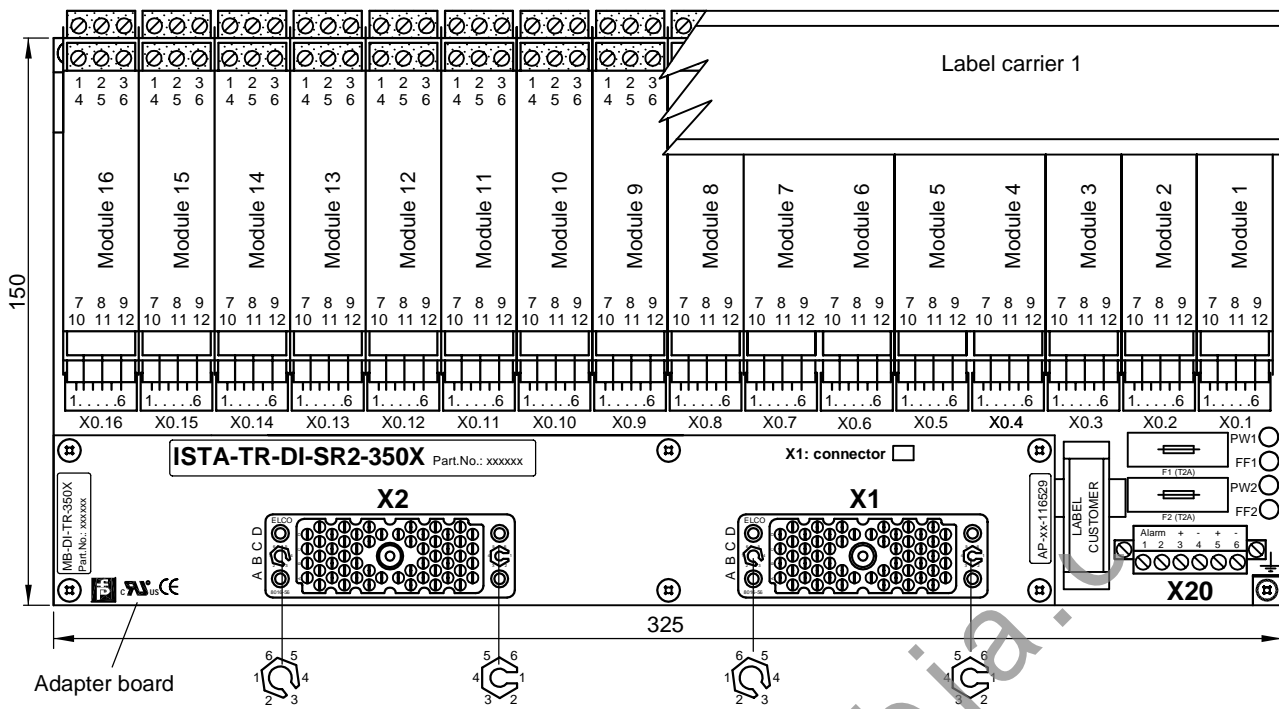

APPLICATION:

TRICONEX I/O card 3503E / 3505E:
16 + 16 points, commoned in groups of 8

Motherboard: connected with connector #1
Module 1 ... 8, channels 1 ... 16

connected with connector #2
Module 9 ... 16, channels 17 ... 32

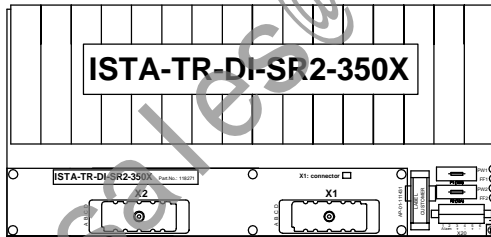

Name	Note
X1	56 pin female system connector ELCO (small key: 1, large key: 3)
X2	56 pin female system connector ELCO (small key: 1, large key: 3)
X0.1 16	6 pin male terminals for cable tree FSY....
X20.3 6	Power supply screw terminals
X20.1, X20.2	Alarm screw terminal
F1, F2	Fuse
PW1, PW2, FF1, FF2	LEDs for power and power failure

Ordering information:	ISTA-TR-DI-SR2-350X-118271	ISTA-TR-DI-SR2-350X-192285	Description
Basic components:			
16 pieces:	KFD2-SR2-Ex2.2S (DI)	KFD2-SR2-2.2S (DI)	KF-Module type (function)
1 piece:	MB-DI-TR-350X-116528	MB-DI-TR-350X-192284	Motherboard without modules
composed by:			
1 piece:	MB-16U5L-103681	MB-16U5L-103681	Basis Motherboard (*)
1 piece:	AP-01-116529	AP-05-116529	Adapter board
1 piece:	KFD0-LC1-16M-99144	KFD0-LC1-16M-99144	Label carrier 1
16 pieces:	FSY-L456-98837	FSY-L456-98837	FSY-Cable tree

(*) Basis Motherboard without modules, adapter board and FSY cable tree (connection between Motherboard and Modules)

copyright according to DIN34
unauthorized distribution and reproduction prohibited

	Motherboard unit Digital Input 16 + 16 channels ISTA-TR-DI-SR2-350X	18.03.02	KT	vB	vB/Sb	
		Date	S TZ	Off. in ch.	contr. techn.	contr. Norm
		Dept.: PA-VP	Nr. 36-7413B			
		Up date: 03.04.06	Replaces: vB/Bro xxxxx / 36-xxxx		Sheet 1	
		MB-16U5L	Scale: 1 : 2, 1:5		of 3	

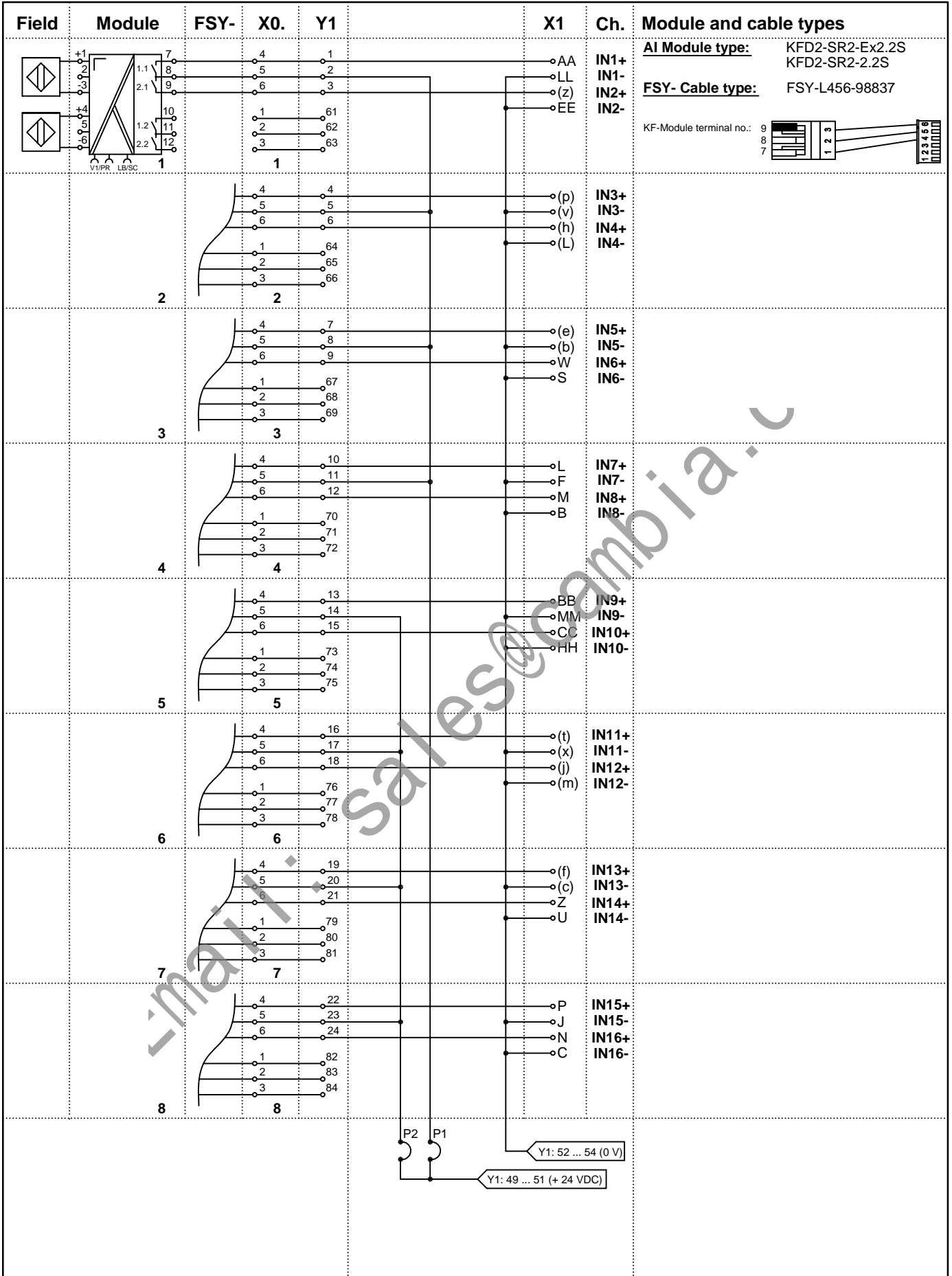

P1, P2 = link (resistor 0 Ohm)

Note: Letters in brackets are small letters

18.03.02		KT	vB	vB/Sb	
Date	S	TZ	Off. in ch.	contr. techn.	contr. Norm
Dept.: PA-VP	Nr. 36-7413B				
Up date: 03.04.06	Replaces: vB/Bro xxxxxx / 36-xxxx		Sheet 2		
MB-16U5L	Scale:		of 3		

PEPPERL+FUCHS
Mannheim-Schönau

Motherboard unit
Digital Input
16 + 16 channels
ISTA-TR-DI-SR2-350X

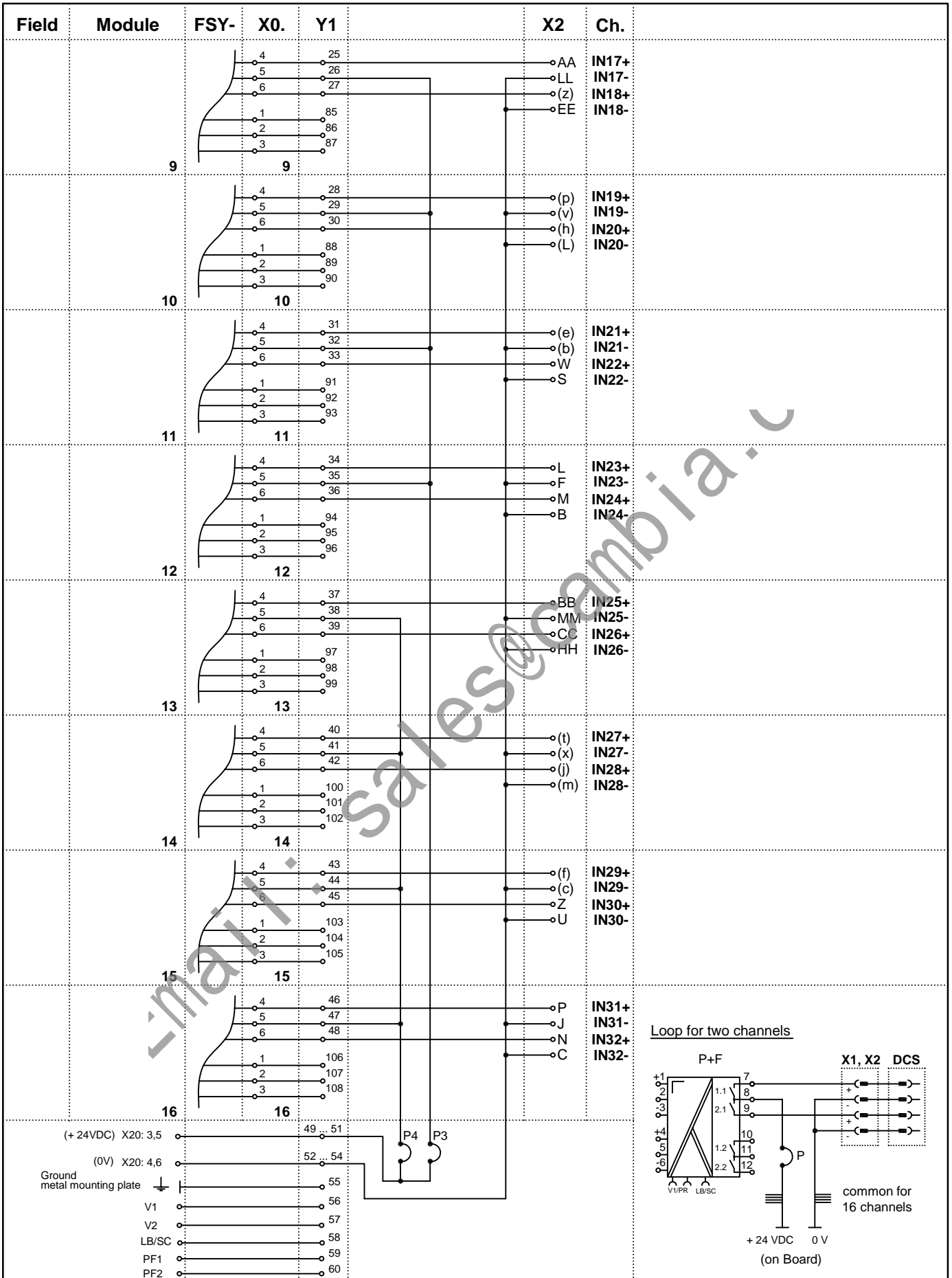

P3, P4 = link (resistor 0 Ohm)

Note: Letters in brackets are small letters

18.03.02		KT	vB	vB/Sb	
Date	S	TZ	Off. in ch.	contr. techn.	contr. Norm
Dept.: PA-VP	vB/Brö		Nr. 36-7413B		
Up date: 03.04.06	Replaces:		xxxxx / 36-xxxx		Sheet 3
MB-16U5L	Scale:				of 3



PEPPERL+FUCHS
Mannheim-Schönau

Motherboard unit
Digital Input
16 + 16 channels
ISTA-TR-DI-SR2-350X

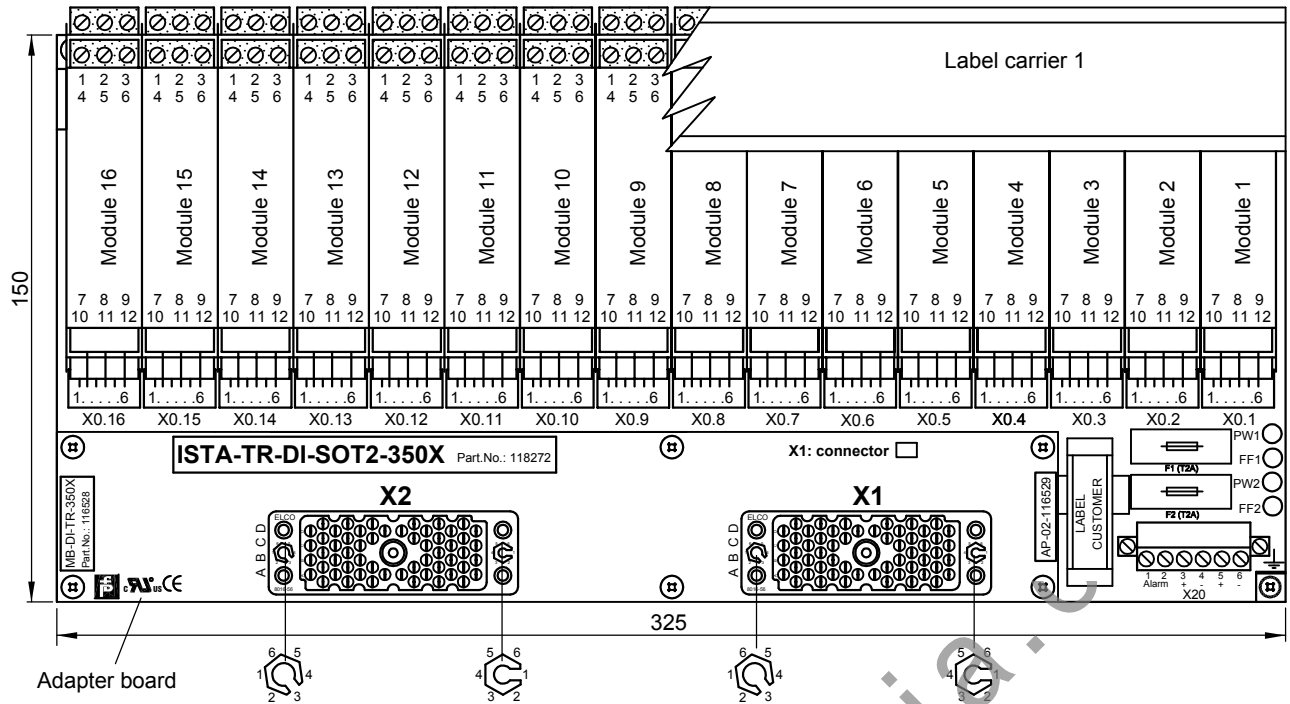

APPLICATION:

TRICONEX I/O card 3503E / 3505E:
16 + 16 points, commoned in groups of 8

Motherboard: connected with connector #1
Module 1 ... 8, channels 1 ... 16

connected with connector #2
Module 9 ... 16, channels 1 ... 16

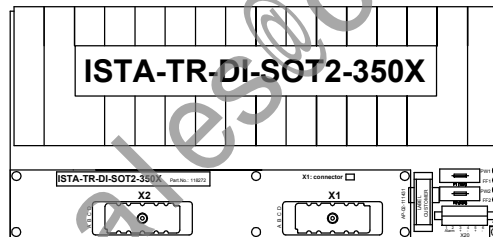

Name	Note
X1	56 pin female system connector ELCO (small key: 1, large key: 3)
X2	56 pin female system connector ELCO (small key: 1, large key: 3)
X0.1 16	6 pin male terminals for cable tree FSY....
X20.3 6	Power supply screw terminals
X20.1, X20.2	Alarm screw terminal
F1, F2	Fuse
PW1, PW2, FF1, FF2	LEDs for power and power failure

Ordering information: ISTA-TR-DI-SOT2-350X-118272

Basic components:	Description
16 pieces: KFD2-SOT2-Ex2 (DI)	KF-Module type (function)
1 piece: MB-DI-TR-350X-116528	Motherboard without modules
composed by:	
1 piece: MB-16U5L-103681	Motherboard without modules, adapter board, FSY cable tree and Label carrier
1 piece: AP-02-116529	Adapter board
1 piece: KFD0-LC1-16M-99144	Label carrier 1
16 pieces: FSY-L456-98837	Cable tree connection KF-Module-Motherboard

18.03.02	KT	vB	vB/Sb	
Date	S TZ	Off. in ch.	contr. techn.	contr. Norm
Dept.: PA-VP	Nr. 36-7169			
Up date: 18.03.04	Replaces: vB/Bro	xxxxx / 36-xxxx	Sheet 1	
MB-16U5L	Scale: 1 : 2, 1:5	of 3		



PEPPERL+FUCHS
Mannheim-Schönau

Motherboard unit
Digital Input
16 + 16 channels
ISTA-TR-DI-SOT2-350X

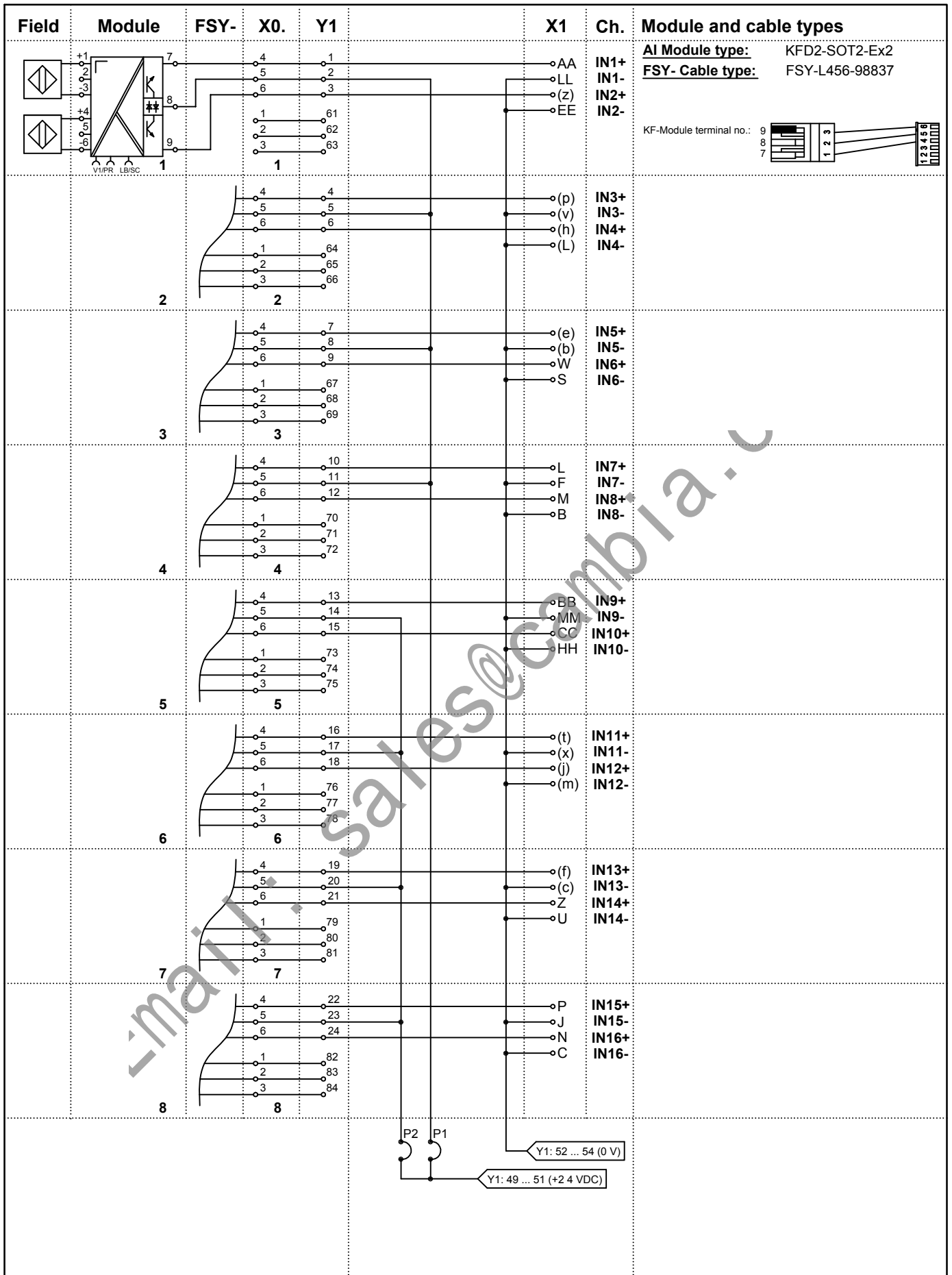

copyright according to DIN34
unauthorized distribution and reproduction prohibited

P1, P2 = link (resistor 0 Ohm)	Note: Letters in brackets are small letters					18.03.02		KT	vB	vB/Sb	
	Date	S	TZ	Off. in ch.	contr. techn.	contr. Norm					
	Motherboard unit Digital Input 16 + 16 channels ISTA-TR-DI-SOT2-350X				Dept.: PA-VP	Nr. 36-7169					
					Up date: 18.03.04	Replaces: xxxxxx / 36-xxxx	Sheet 2				
					MB-16U5L	Scale:	of 3				

copyright according to DIN34
 unauthorized distribution and reproduction prohibited

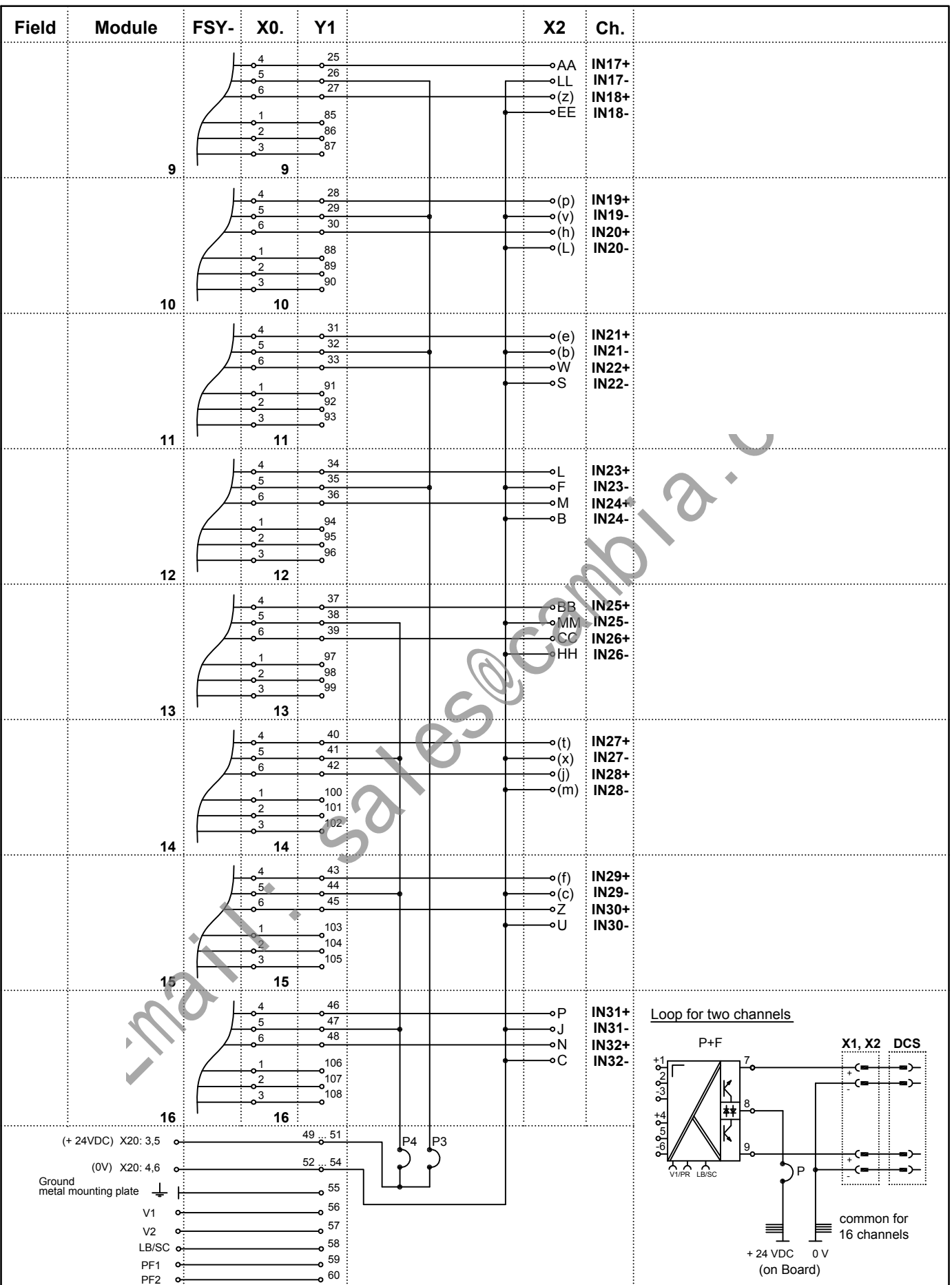

P3, P4 = link (resistor 0 Ohm)

Note: Letters in brackets are small letters

18.03.02		KT	vB	vB/Sb	
Date	S	TZ	Off. in ch.	contr. techn.	contr. Norm
Dept.: PA-VP	Nr. 36-7169				
Up date: 18.03.04	Replaces: xxxxx / 36-xxxx		Sheet 3		
MB-16U5L	Scale:		of 3		

PEPPERL+FUCHS
 Mannheim-Schönau

Motherboard unit
 Digital Input
 16 + 16 channels
ISTA-TR-DI-SOT2-350X

3. 3504E / 3564 Application

(32 + 32 channels DI)

	Page
Simplified schematic 3504E	3- 1
Simplified schematic 3564	3- 3
2 x Motherboard ISTA-TR-DI-SR2-35XX-118278	3- 4
Part No.:	118278
Function:	Digital Input
Channels:	32
System cable:	(ELCO connector)
KF- Module:	KFD2-SR2-Ex2.2S (dual channel)
Simplified schematic:	drawing no. 36-9281 drawing no. 36-9282
Wiring Diagram:	drawing no. 36-7361
2 x Motherboard ISTA-TR-DI-SOT2-35XX-118279	3- 7
Part No.:	118279
Function:	Digital Input
Channels:	32
System cable:	(ELCO connector)
KF- Module:	KFD2-SOT2-Ex2 (dual channel)
Simplified schematic:	drawing no. 36-9281 drawing no. 36-9282
Wiring Diagram:	drawing no. 36-7188

3504E DIGITAL INPUT MODULE

**Simplified schematic of a typical 64-point commoned 24 VDC digital input module
(1 of 64 points shown)**

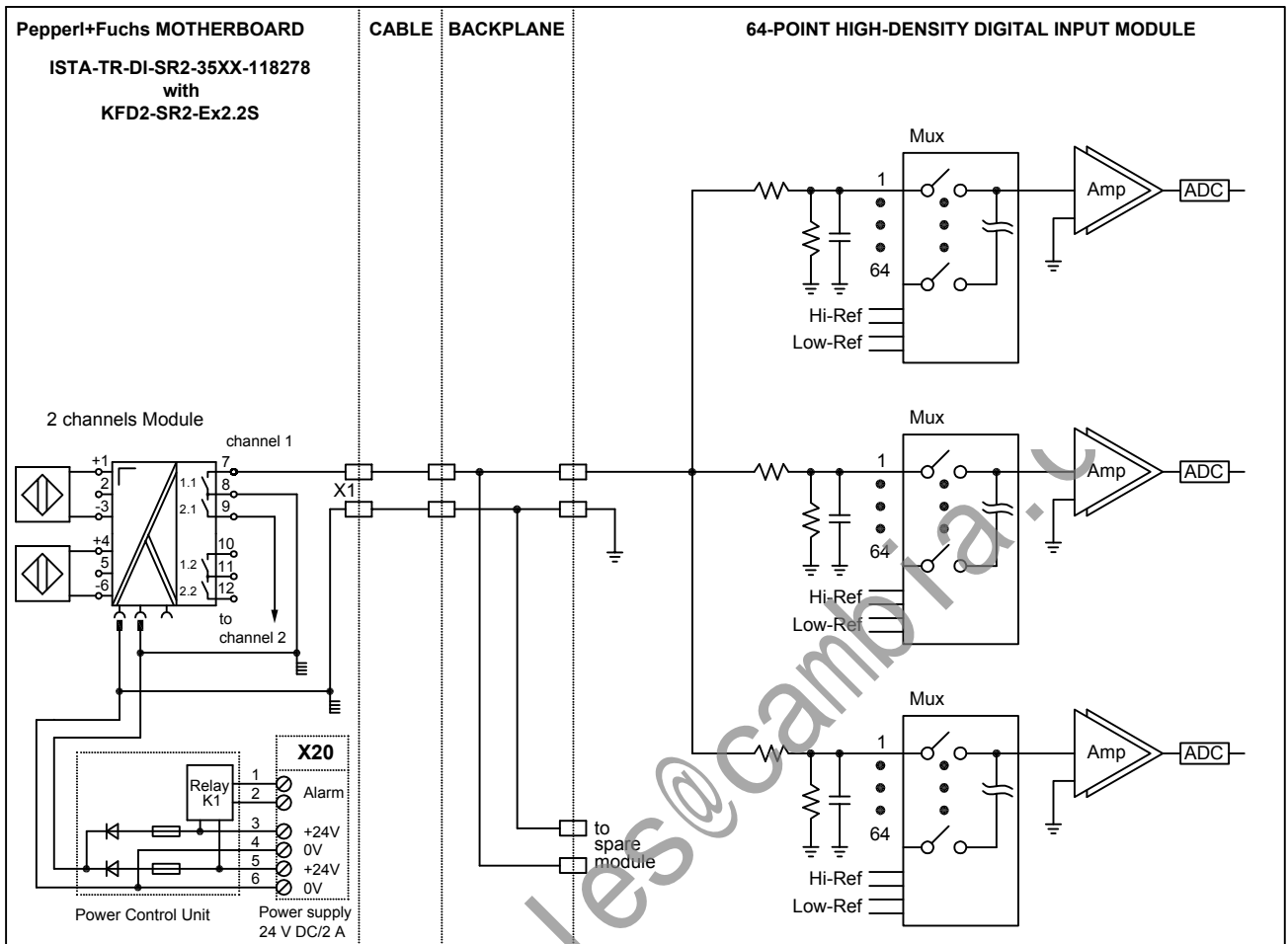

Pin assignment of connector #A (56 pin ELCO female)

Pin	AA	KK	LL	z	DD	EE	p	u	v	h	k	l	e	a
Signal	IN1	*	IN2	IN3	RTN	IN4	IN5	*	IN6	IN7	RTN	IN8	IN9	*
Pin	b	W	R	S	L	E	F	M	A	B	BB	NN	MM	CC
Signal	IN10	IN11	RTN	IN12	IN13	RTN	IN14	IN15	RTN	IN16	IN17	RTN	IN18	IN19
Pin	JJ	HH	t	y	x	j	n	m	f	d	c	Z	V	U
Signal	RTN	IN20	IN21	RTN	IN22	IN23	RTN	IN24	IN25	RTN	IN26	IN27	RTN	IN28
Pin	P	K	J	N	D	C	T	H	w	FF	r	s	X	Y
Signal	IN29	RTN	IN30	IN31	RTN	IN32	CGND	CGND	CGND	CGND	**	**	**	**

Pin assignment of connector #B (56 pin ELCO female)

Pin	AA	KK	LL	z	DD	EE	p	u	v	h	k	l	e	a
Signal	IN33	RTN	IN34	IN35	RTN	IN36	IN37	RTN	IN38	IN39	RTN	IN40	IN41	RTN
Pin	b	W	R	S	L	E	F	M	A	B	BB	NN	MM	CC
Signal	IN42	IN43	RTN	IN44	IN45	RTN	IN46	IN47	RTN	IN48	IN49	RTN	IN50	IN51
Pin	JJ	HH	t	y	x	j	n	m	f	d	c	Z	V	U
Signal	RTN	IN52	IN53	RTN	IN54	IN55	RTN	IN56	IN57	RTN	IN58	IN59	RTN	IN60
Pin	P	K	J	N	D	C	T	H	w	FF	r	s	X	Y
Signal	IN61	RTN	IN62	IN63	RTN	IN64	CGND	CGND	CGND	CGND	**	**	**	**

* Reserved for internal use. Do not connect for any purpose.
** not used
CGND is the chassis ground

02.03.99		AJ	AJ	--	
Date	S	TZ	Off. in ch.	contr. techn.	contr. Norm



D-TR-3504E

Dept.: PA-VP	Nr. 36-9281
vB/Bro	Replaces: XXXXX / 36-XXXX
Up date: 19.03.04	Sheet 1
Scale: - : -	of 2

copyright according to DIN34
unauthorized distribution and reproduction prohibited

3504E DIGITAL INPUT MODULE

**Simplified schematic of a typical 64-point commoned 24 VDC digital input module
(1 of 64 points shown)**

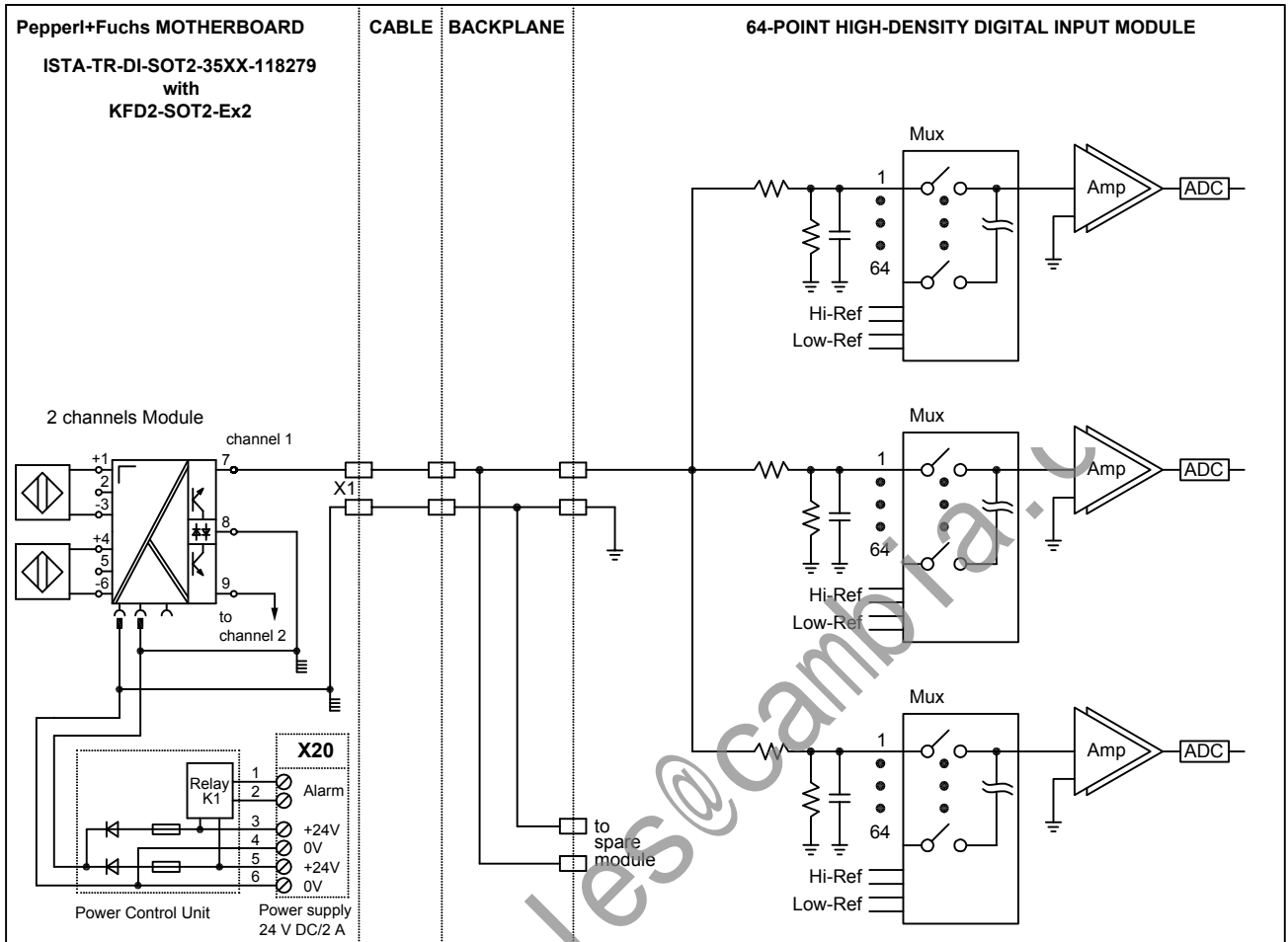

Pin assignment of connector #A (56 pin ELCO female)

Pin	AA	KK	LL	z	DD	EE	p	u	v	h	k	l	e	a
Signal	IN1	*	IN2	IN3	RTN	IN4	IN5	*	IN6	IN7	RTN	IN8	IN9	*
Pin	b	W	R	S	L	E	F	M	A	B	BB	NN	MM	CC
Signal	IN10	IN11	RTN	IN12	IN13	RTN	IN14	IN15	RTN	IN16	IN17	RTN	IN18	IN19
Pin	JJ	HH	t	y	x	j	n	m	f	d	c	Z	V	U
Signal	RTN	IN20	IN21	RTN	IN22	IN23	RTN	IN24	IN25	RTN	IN26	IN27	RTN	IN28
Pin	P	K	J	N	D	C	T	H	w	FF	r	s	X	Y
Signal	IN29	RTN	IN30	IN31	RTN	IN32	CGND	CGND	CGND	CGND	**	**	**	**

Pin assignment of connector #B (56 pin ELCO female)

Pin	AA	KK	LL	z	DD	EE	p	u	v	h	k	l	e	a
Signal	IN33	RTN	IN34	IN35	RTN	IN36	IN37	RTN	IN38	IN39	RTN	IN40	IN41	RTN
Pin	b	W	R	S	L	E	F	M	A	B	BB	NN	MM	CC
Signal	IN42	IN43	RTN	IN44	IN45	RTN	IN46	IN47	RTN	IN48	IN49	RTN	IN50	IN51
Pin	JJ	HH	t	y	x	j	n	m	f	d	c	Z	V	U
Signal	RTN	IN52	IN53	RTN	IN54	IN55	RTN	IN56	IN57	RTN	IN58	IN59	RTN	IN60
Pin	P	K	J	N	D	C	T	H	w	FF	r	s	X	Y
Signal	IN61	RTN	IN62	IN63	RTN	IN64	CGND	CGND	CGND	CGND	**	**	**	**

* Reserved for internal use. Do not connect for any purpose.
** not used
CGND is the chassis ground

02.03.99		AJ	AJ	--	
Date	S	TZ	Off. in ch.	contr. techn.	contr. Norm



D-TR-3504E

Dept.: PA-VP	Nr. 36-9281
Up date: 19.03.04	Replaces: XXXXX / 36-XXXX
Scale: - : -	Sheet 2 of 2

copyright according to DIN34
unauthorized distribution and reproduction prohibited

3564 DIGITAL INPUT MODULE

Simplified schematic of a typical 64-point commoned 24 VDC digital input module
(1 of 64 points shown)

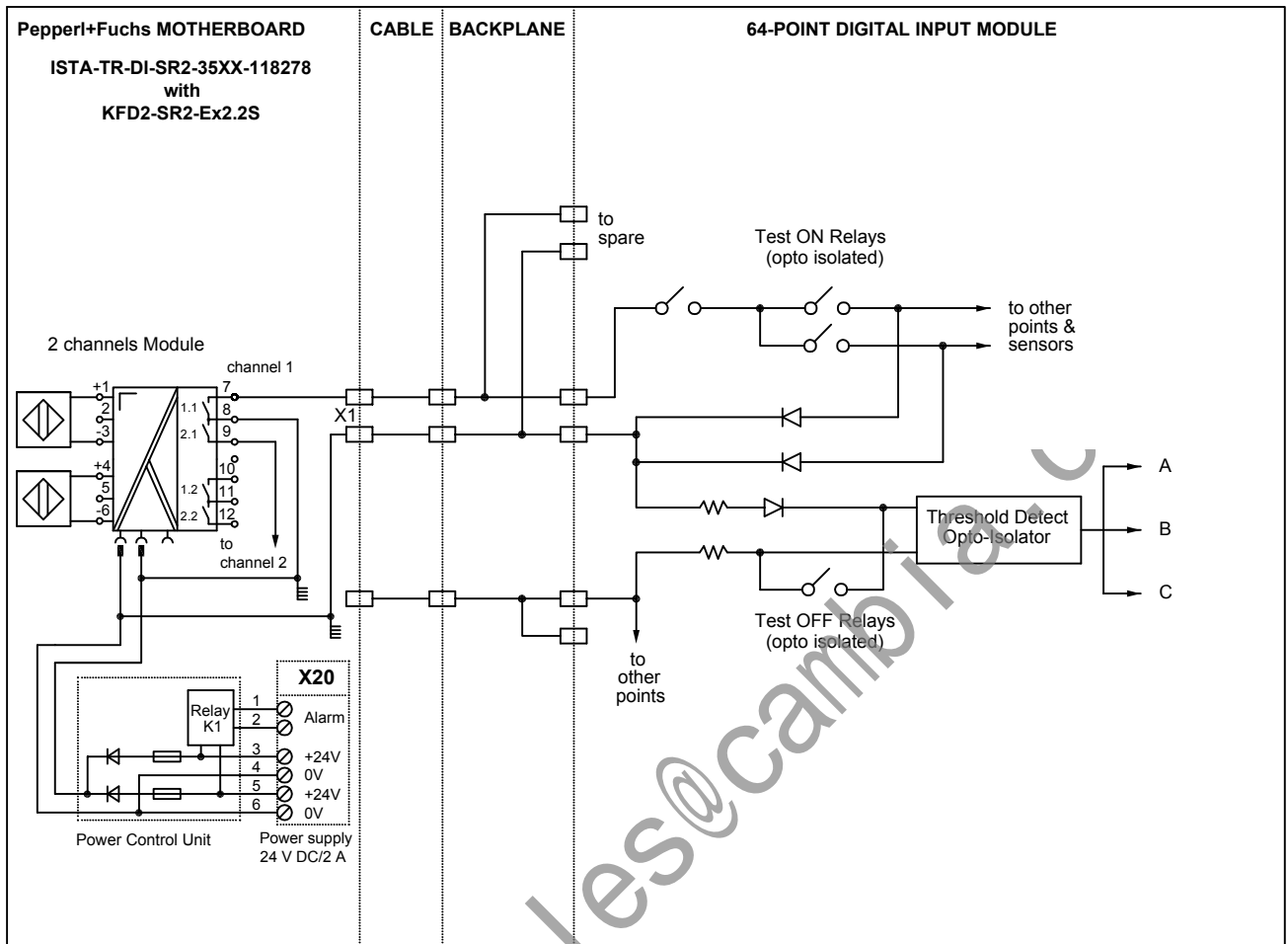

Pin assignment of connector #A (56 pin ELCO female)

Pin	AA	KK	LL	z	DD	EE	p	u	v	h	k	l	e	a
Signal	IN1	*	IN2	IN3	PWR	IN4	IN5	*	IN6	IN7	PWR	IN8	IN9	*
Pin	b	W	R	S	L	E	F	M	A	B	BB	NN	MM	CC
Signal	IN10	IN11	PWR	IN12	IN13	RTN	IN14	IN15	RTN	IN16	IN17	RTN	IN18	IN19
Pin	JJ	HH	t	y	x	j	n	m	f	d	c	Z	V	U
Signal	RTN	IN20	IN21	RTN	IN22	IN23	RTN	IN24	IN25	RTN	IN26	IN27	RTN	IN28
Pin	P	K	J	N	D	C	T	H	w	FF	r	s	X	Y
Signal	IN29	RTN	IN30	IN31	RTN	IN32	CGND	CGND	CGND	CGND	**	**	**	**

Pin assignment of connector #B (56 pin ELCO female)

Pin	AA	KK	LL	z	DD	EE	p	u	v	h	k	l	e	a
Signal	IN33	RTN	IN34	IN35	PWR	IN36	IN37	RTN	IN38	IN39	PWR	IN40	IN41	RTN
Pin	b	W	R	S	L	E	F	M	A	B	BB	NN	MM	CC
Signal	IN42	IN43	PWR	IN44	IN45	RTN	IN46	IN47	RTN	IN48	IN49	RTN	IN50	IN51
Pin	JJ	HH	t	y	x	j	n	m	f	d	c	Z	V	U
Signal	RTN	IN52	IN53	RTN	IN54	IN55	RTN	IN56	IN57	RTN	IN58	IN59	RTN	IN60
Pin	P	K	J	N	D	C	T	H	w	FF	r	s	X	Y
Signal	IN61	RTN	IN62	IN63	RTN	IN64	CGND	CGND	CGND	CGND	**	**	**	**

* Reserved for internal use. Do not connect for any purpose.

** not used

CGND is the chassis ground

02.03.99		AJ	AJ	--	
Date	S	TZ	Off. in ch.	contr. techn.	contr. Norm
Dept.:	PA-VP	Nr. 36-9282			
Up date:	vB/Bro 19.03.04	Replaces: XXXXX / 36-XXXX			Sheet 1
Scale:				- : -	of 2



PEPPERL+FUCHS
Mannheim-Schönau

D-TR-3564

3564 DIGITAL INPUT MODULE

Simplified schematic of a typical 64-point commoned 24 VDC digital input module
(1 of 64 points shown)

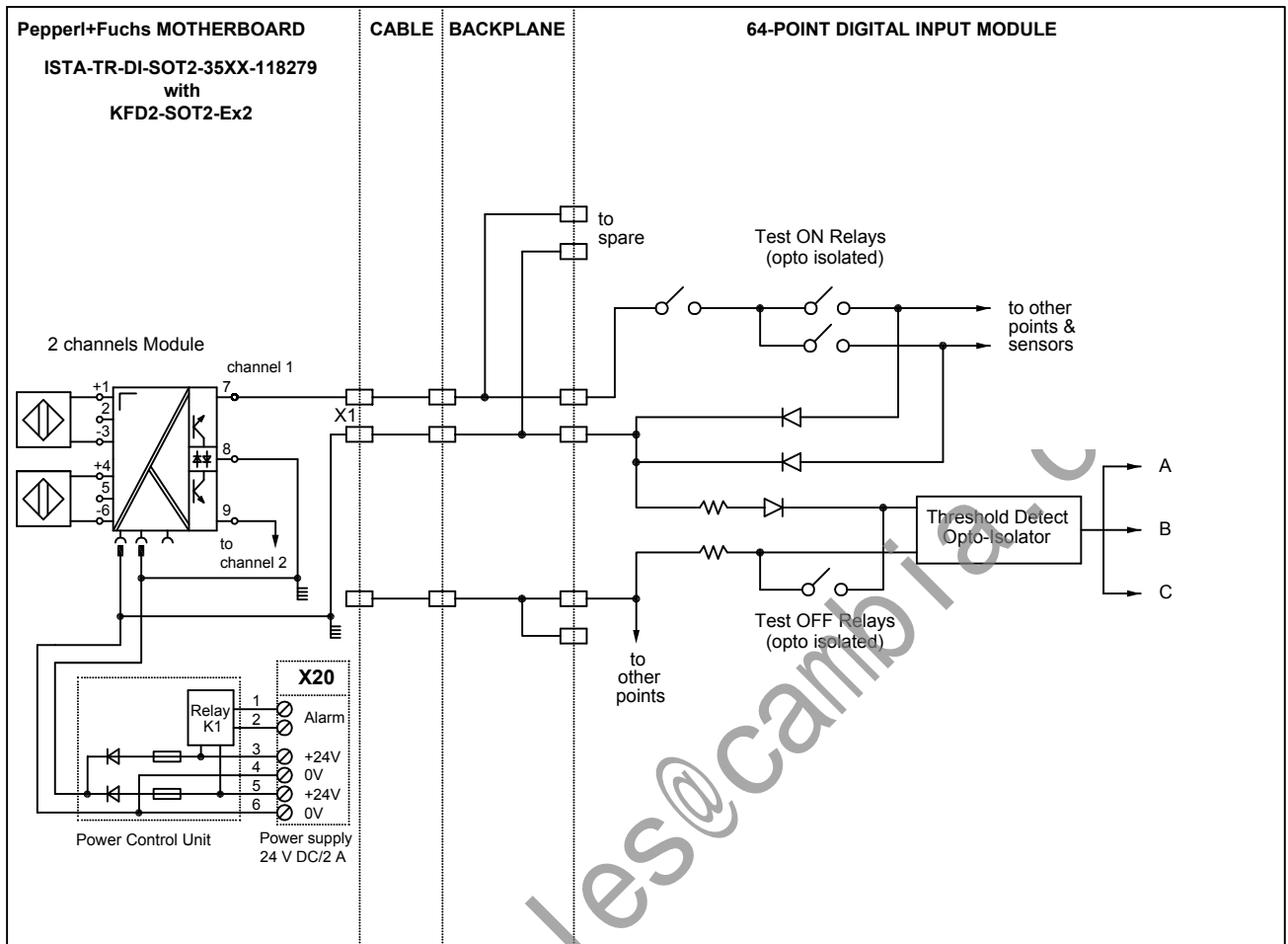

Pin assignment of connector #A (56 pin ELCO female)

Pin	AA	KK	LL	z	DD	EE	p	u	v	h	k	l	e	a
Signal	IN1	*	IN2	IN3	PWR	IN4	IN5	*	IN6	IN7	PWR	IN8	IN9	*
Pin	b	W	R	S	L	E	F	M	A	B	BB	NN	MM	CC
Signal	IN10	IN11	PWR	IN12	IN13	RTN	IN14	IN15	RTN	IN16	IN17	RTN	IN18	IN19
Pin	JJ	HH	t	y	x	j	n	m	f	d	c	Z	V	U
Signal	RTN	IN20	IN21	RTN	IN22	IN23	RTN	IN24	IN25	RTN	IN26	IN27	RTN	IN28
Pin	P	K	J	N	D	C	T	H	w	FF	r	s	X	Y
Signal	IN29	RTN	IN30	IN31	RTN	IN32	CGND	CGND	CGND	CGND	**	**	**	**

Pin assignment of connector #B (56 pin ELCO female)

Pin	AA	KK	LL	z	DD	EE	p	u	v	h	k	l	e	a
Signal	IN33	RTN	IN34	IN35	PWR	IN36	IN37	RTN	IN38	IN39	PWR	IN40	IN41	RTN
Pin	b	W	R	S	L	E	F	M	A	B	BB	NN	MM	CC
Signal	IN42	IN43	PWR	IN44	IN45	RTN	IN46	IN47	RTN	IN48	IN49	RTN	IN50	IN51
Pin	JJ	HH	t	y	x	j	n	m	f	d	c	Z	V	U
Signal	RTN	IN52	IN53	RTN	IN54	IN55	RTN	IN56	IN57	RTN	IN58	IN59	RTN	IN60
Pin	P	K	J	N	D	C	T	H	w	FF	r	s	X	Y
Signal	IN61	RTN	IN62	IN63	RTN	IN64	CGND	CGND	CGND	CGND	**	**	**	**

* Reserved for internal use. Do not connect for any purpose.
** not used
CGND is the chassis ground

02.03.99		AJ	AJ	--	
Date	S	TZ	Off. in ch.	contr. techn.	contr. Norm
Dept.:	PA-VP	Nr. 36-9282			
Up date:	vB/Bro 19.03.04	Replaces: XXXXX / 36-XXXX			Sheet 2
Scale:				- : -	of 2



D-TR-3564

copyright according to DIN34
unauthorized distribution and reproduction prohibited

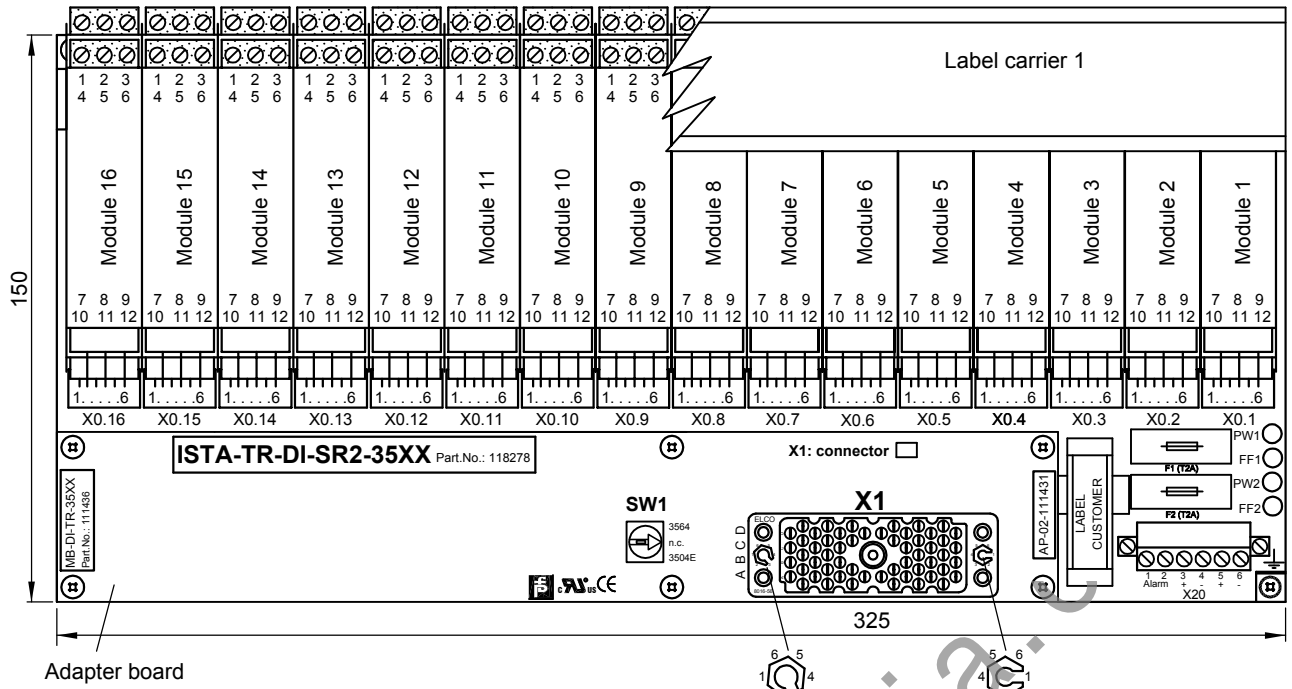

APPLICATION:

TRICONEX I/O card 3504E / 3564: will be required 2 x ISTA-TR-DI-SR2-35XX-118278
32 + 32 points, commoned

Motherboard 2: connected with connector #B
Module 1 ... 16, channels 17 ... 32

Motherboard 1: connected with connector #A
Module 1 ... 16, channels 17 ... 32

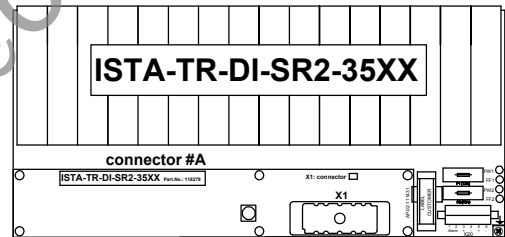
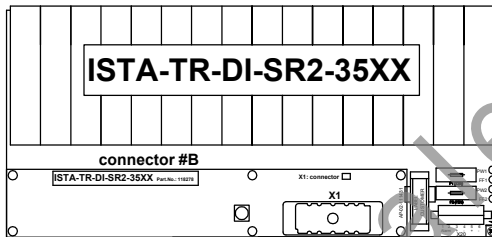

Name	Note
X1	56 pin female system connector ELCO (small key: 1, large key: 3)
----	----
X0.1 16	6 pin male terminals for cable tree FSY....
X20.3 6	Power supply screw terminals
X20.1, X20.2	Alarm screw terminal
F1, F2	Fuse
PW1, PW2, FF1, FF2	LEDs for power and power failure

Ordering information: ISTA-TR-DI-SR2-35XX-118278

Basic components:	Description
16 pieces: KFD2-SR2-Ex2.2S (DI)	KF-Module type (function)
1 piece: MB-DI-TR-35XX-111436	Motherboard without modules
composed by:	
1 piece: MB-16U5L-103681	Motherboard without modules, adapter board, FSY cable tree and Label carrier
1 piece: AP-02-111431	Adapter board
1 piece: KFD0-LC1-16M-99144	Label carrier 1
16 pieces: FSY-L456-98837	Cable tree connection KF-Module-Motherboard

18.03.02	KT	vB	vB/Sb
Date	S TZ	Off. in ch.	contr. techn.
			contr. Norm



PEPPERL+FUCHS
Mannheim-Schönau

Motherboard unit
Digital Input
32 channels
ISTA-TR-DI-SR2-35XX

Dept.: PA-VP	Nr. 36-7361
Up date: vB/Bro 19.03.04	Replaces: xxxxxx / 36-xxxx
MB-16U5L	Scale: 1 : 2, 1 : 5
	Sheet 1 of 3

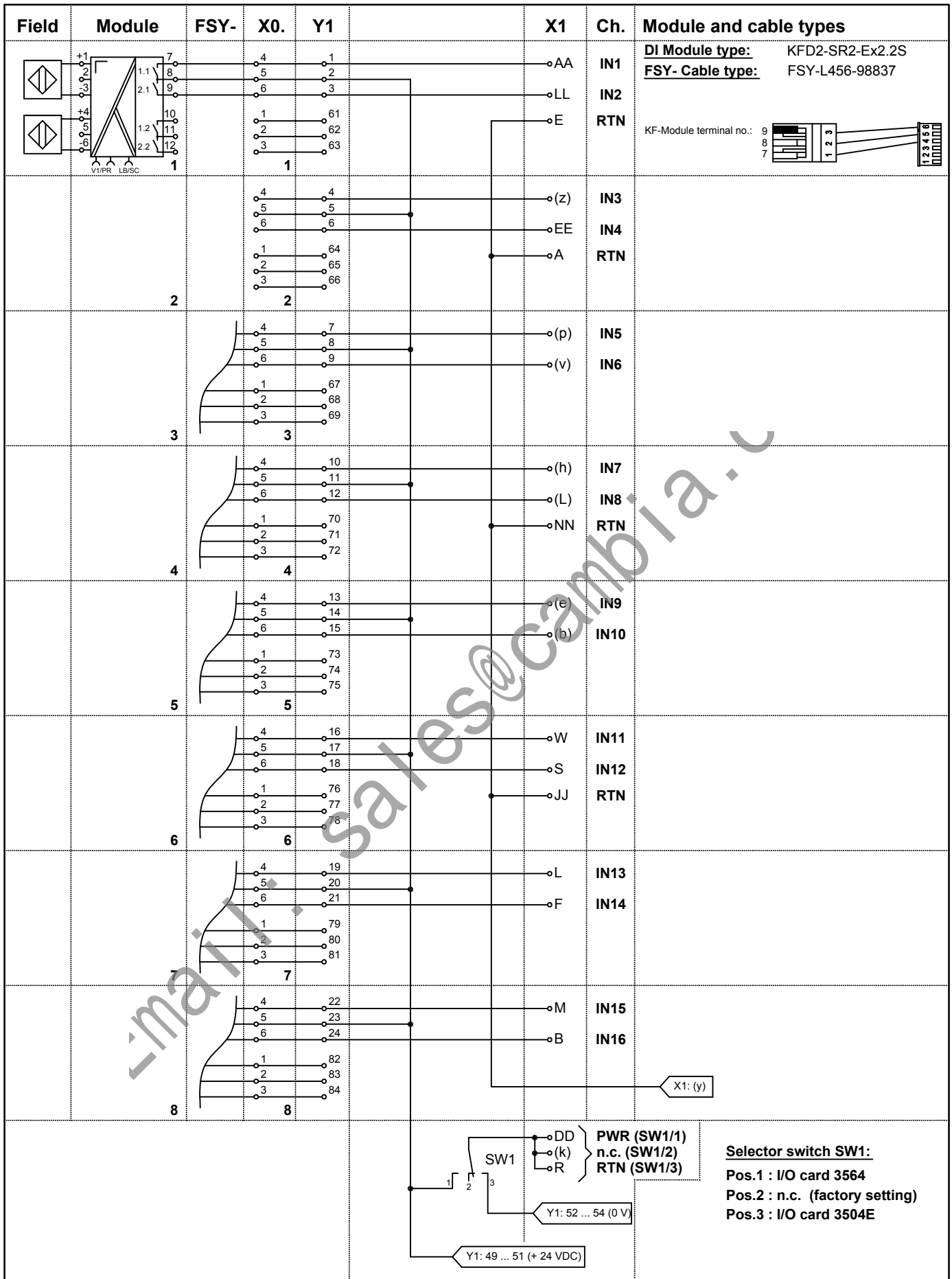

copyright according to DIN34
 unauthorized distribution and reproduction prohibited

	Motherboard unit Digital Input 32 channels ISTA-TR-DI-SR2-35XX				
	18.03.02		KT	vB	vB/Sb
	Date	S	TZ	Off. in ch.	contr. techn.
	Dept.: PA-VP	Nr. 36-7361		Replaces:	Sheet 2
Up date: 19.03.04	xxxxx / 36-xxxx		Scale: - : -	of 3	

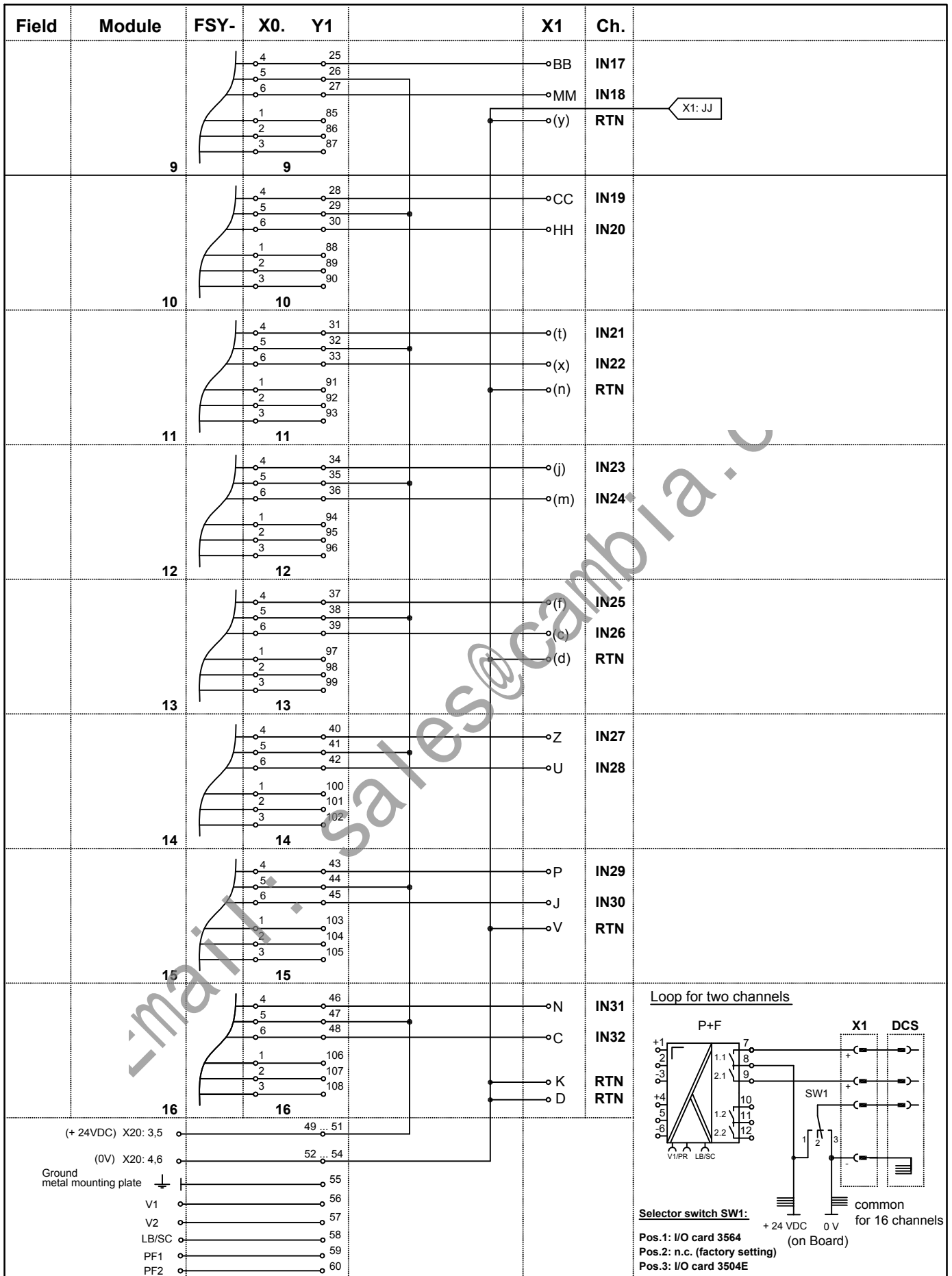

copyright according to DIN34
unauthorized distribution and reproduction prohibited

		Note: Letters in brackets are small letters			
		18.03.02	KT	vB	vB/Sb
Date	S TZ	Off. in ch.	contr. techn.	contr. Norm	
Dept.: PA-VP Up date: vB/Bro 19.03.04		Nr. 36-7361 Replaces: xxxxxx / 36-xxxx			
--		Scale:	- : -	Sheet 3 of 3	

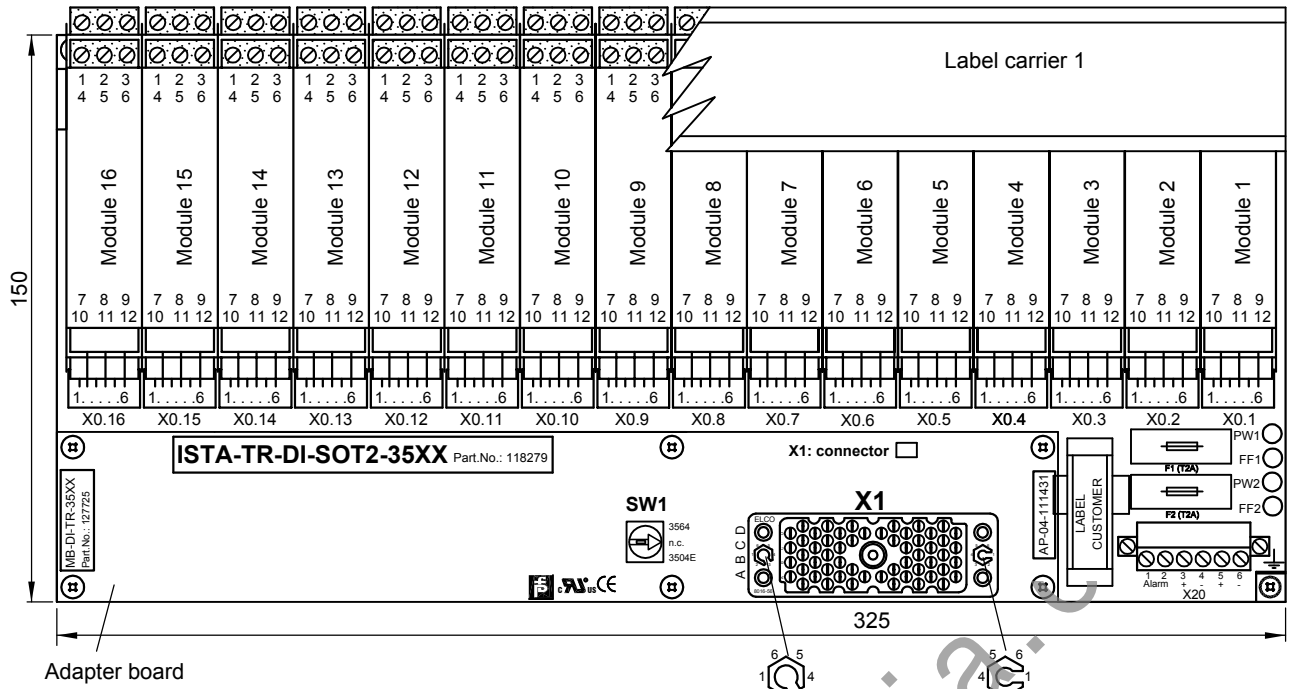

APPLICATION:

TRICONEX I/O card 3504E / 3564: will be required 2 x ISTA-TR-DI-SOT2-35XX-118279
32 + 32 points, commoned

Motherboard 2: connected with connector #B
Module 1 ... 16, channels 17 ... 32

Motherboard 1: connected with connector #A
Module 1 ... 16, channels 17 ... 32

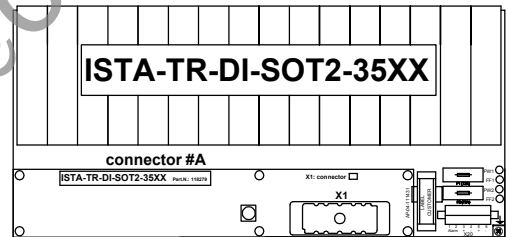
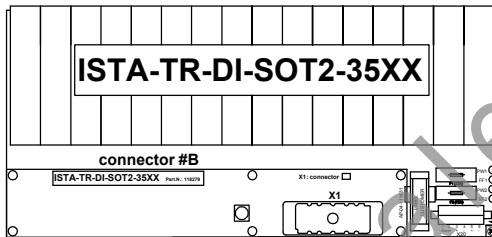

Name	Note
X1	56 pin female system connector ELCO (small key: 1, large key: 3)
----	---
X0.1 16	6 pin male terminals for cable tree FSY....
X20.3 6	Power supply screw terminals
X20.1, X20.2	Alarm screw terminal
F1, F2	Fuse
PW1, PW2, FF1, FF2	LEDs for power and power failure

Ordering information: ISTA-TR-DI-SOT2-35XX-118279

Basic components:	Description
16 pieces:	KFD2-SOT2-Ex2 (DI) KF-Module type (function)
1 piece:	MB-DI-TR-35XX-127725 Motherboard without modules
composed by:	
1 piece:	MB-16U5L-103681 Motherboard without modules, adapter board, FSY cable tree and Label carrier
1 piece:	AP-04-111431 Adapter board
1 piece:	KFD0-LC1-16M-99144 Label carrier 1
16 pieces:	FSY-L456-98837 Cable tree connection KF-Module-Motherboard

18.03.02	KT	vB	vB/Sb
Date	S TZ	Off. in ch.	contr. techn.



Motherboard unit
Digital Input
32 channels
ISTA-TR-DI-SOT2-35XX

Dept.: PA-VP	Nr. 36-7188
Up date: 22.03.04	Replaces: xxxxxx / 36-xxxx
MB-16U5L	Scale: 1 : 2, 1 : 5

Sheet 1
of 3

copyright according to DIN34
unauthorized distribution and reproduction prohibited

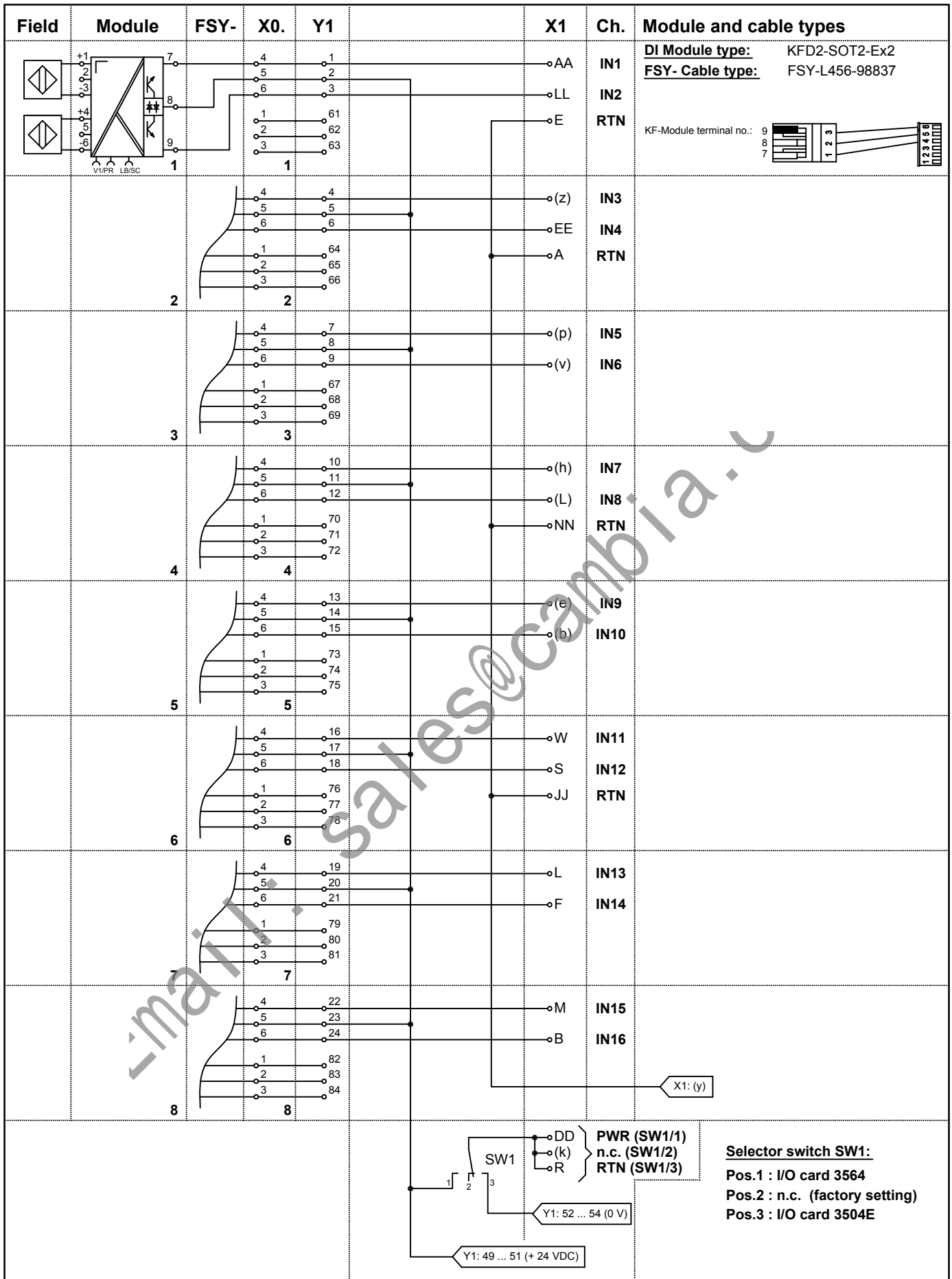

copyright according to DIN34 unauthorized distribution and reproduction prohibited

	Note: Letters in brackets are small letters				
	21.03.02		KT	vB	vB/Sb
	Date	S	TZ	Off. in ch.	contr. techn.
	Dept.: PA-VP Up date: 22.03.04		Nr. 36-7188 Replaces: xxxxx / 36-xxxx		
Motherboard unit Digital Input 32 channels ISTA-TR-DI-SOT2-35XX				Sheet 2	of 3

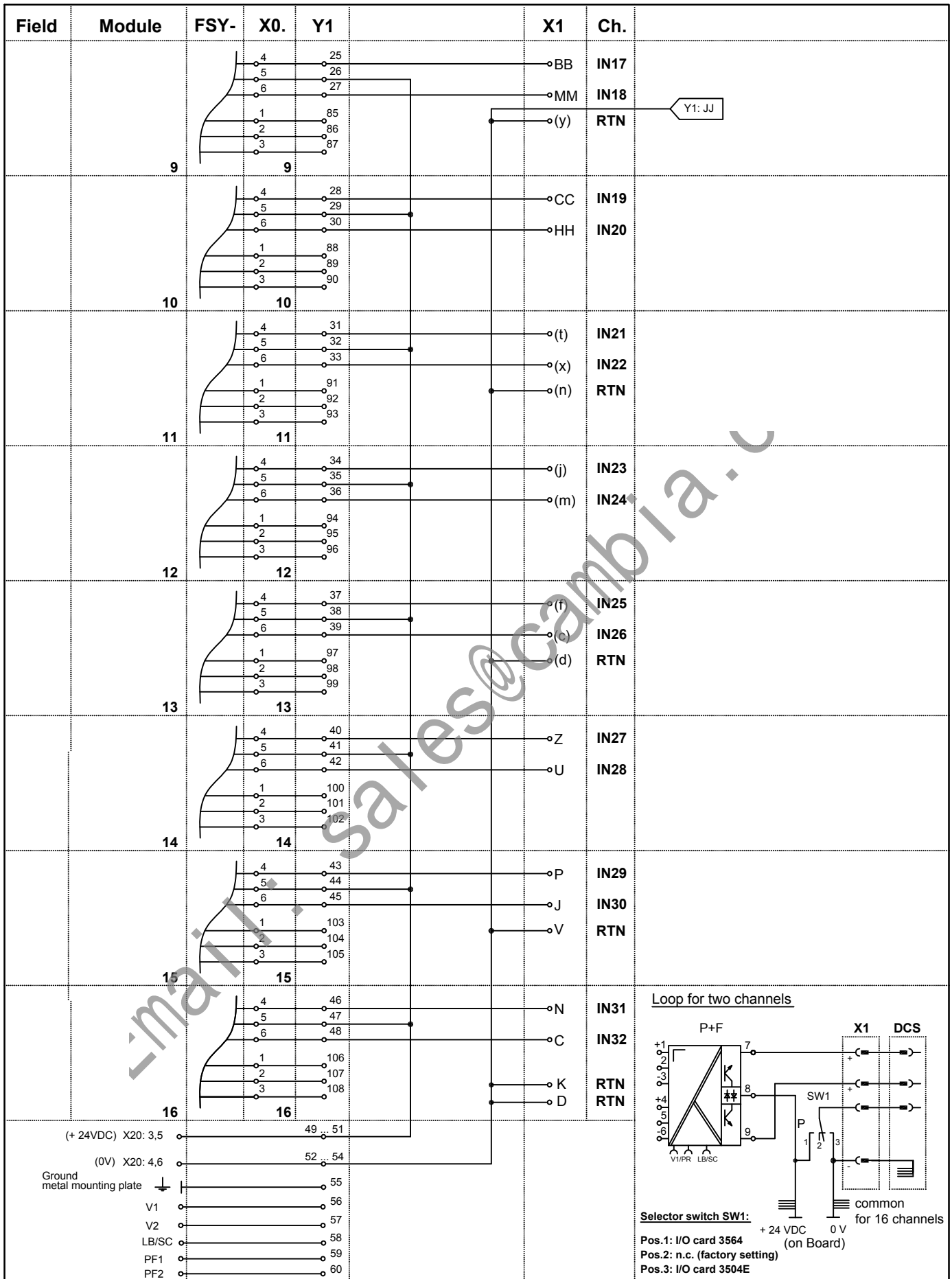

copyright according to DIN34
 unauthorized distribution and reproduction prohibited

		Note: Letters in brackets are small letters		21.03.02	KT	vB	vB/Sb	
Date	S	TZ	Off. in ch.	contr. techn.	contr. Norm			
Dept.: PA-VP		vB/Bro		Nr. 36-7188				
Up date: 22.03.04		Replaces: xxxxx / 36-xxxx		Sheet 3				
--		Scale: - : -		of 3				



Motherboard unit
 Digital Input
 32 channels
ISTA-TR-DI-SOT2-35XX

4. 3511 Application

(8 channels DI)

Page

Motherboard MB-DI-TR-3511-183386..... 4- 1

Part No.: 183386
Function: Digital Input
Channels: 8
System cable: (ELCO connector)
KF- Module: KFD2-SOT2-EX1.LW (single channel)

Wiring Diagram: drawing no. 36-7697

email: sales@cambia.it

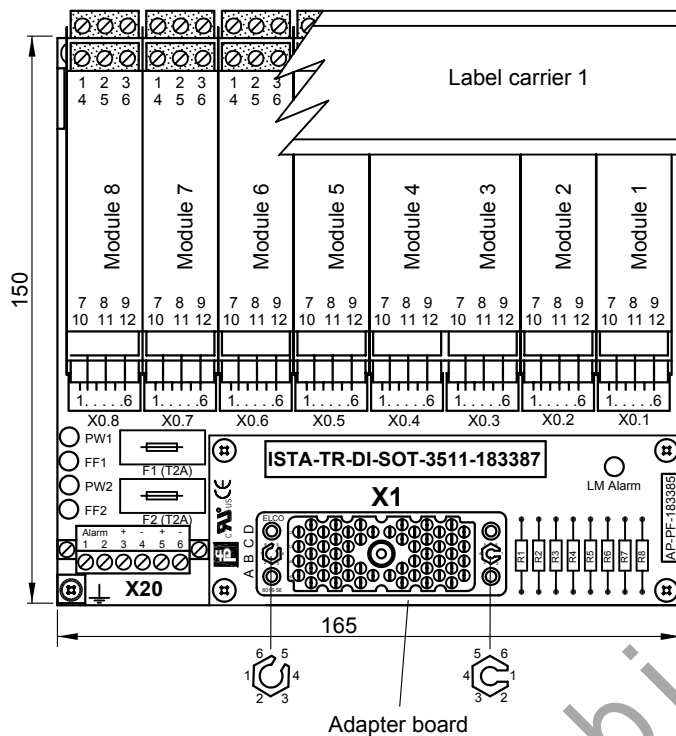

APPLICATION:

TRICONEX I/O card 3511 with KF-module KFD2-SOT2-Ex1.LB:
8 points (Pulse 1Hz...5000Hz)

Name	Note
X1	56 pin female system connector ELCO (small key: 1, large key: 5)
R1...R8	Termination resistor 4K7
X0.1 8	6 pin male terminals for cable tree FSY....
X20.3 6	Power supply screw terminals
X20.1...2	Alarm screw terminal
F1, F2	Fuse T2A
PW1, PW2, FF1, FF2	LEDs for power and power failure

Ordering information: ISTA-TR-DI-SOT-3511-183387

Basic components:	Description
8 pieces: KFD2-SOT2-Ex1.LB (DI)	KF-Module type (function)
1 piece: MB-DI-TR-3511-183386	Motherboard without modules
composed by:	
1 piece: MB-8U2-Y97680	Motherboard without modules, adapter board, FSY cable tree and Label carrier
1 piece: AP-PF-183385	Adapter board
1 piece: KFD0-LC1-8M-99143	Label carrier 1
8 pieces: FSY-L450-98833	Cable tree connection KF-Module-Motherboard

copyright according to DIN34
unauthorized distribution and reproduction prohibited

	PEPPERL+FUCHS Mannheim-Schönau	Motherboard unit Digital Input (Pulse) 8 channels ISTA-TR-DI-SOT-3511-.....	10.05.05	Sb	Sb	vB/Sb		
			Date	S	TZ	Off. in ch.	contr. techn.	contr. Norm
			Dept.: PA-VP	Nr. 36-7697		Replaces: xxxxxx/ 36-xxxx		Sheet 1
			Up date: xx/xx/xx	MB-8U2	Scale: 1 : 2	of 2		

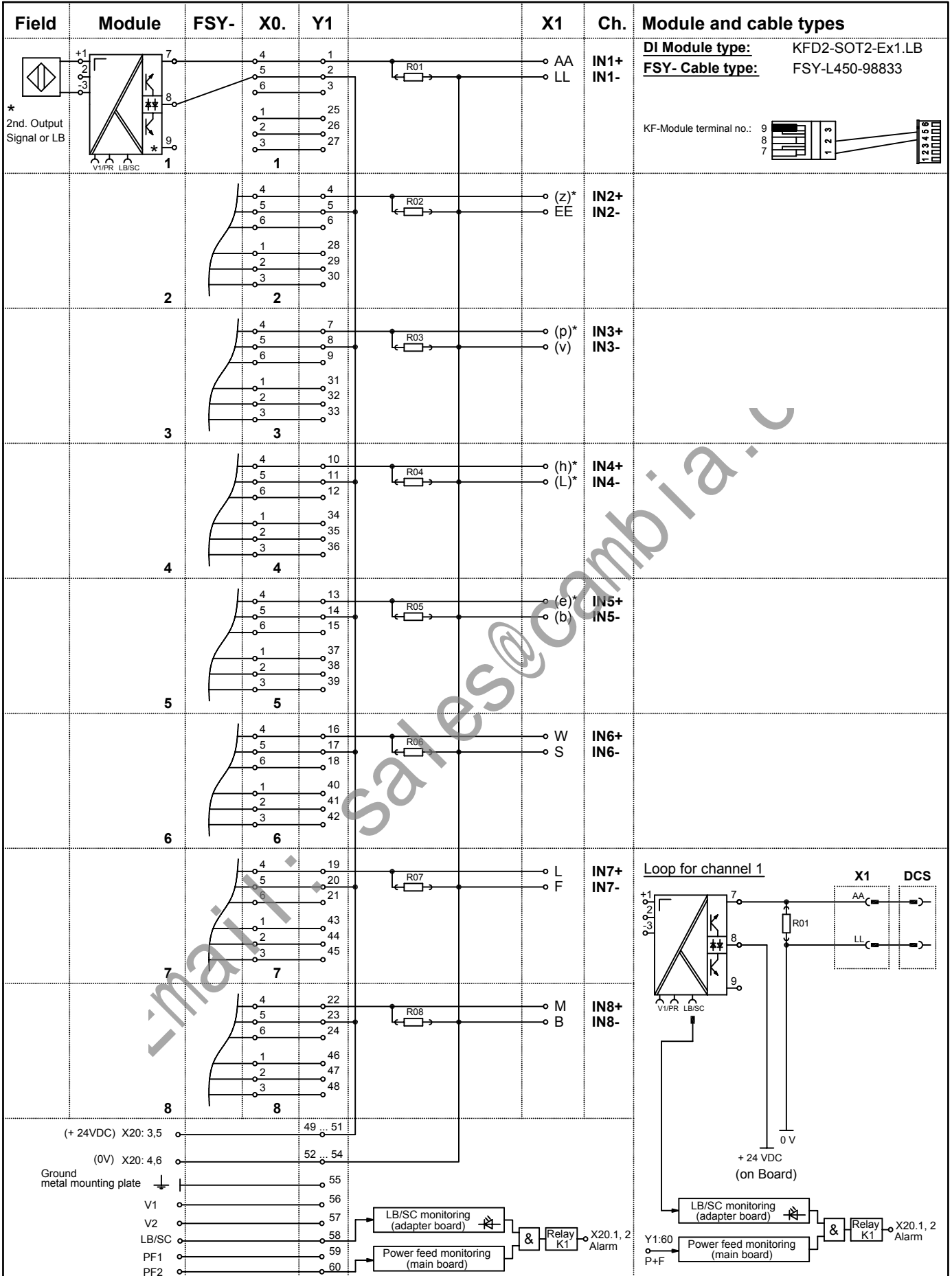

R1...R8 = 4K7 (On solder pad!)
* Letters in brackets are small letters!

08.07.05	Sb	Sb	Sb/vB	
Date	S	TZ	Off. in ch. contr. techn.	contr. Norm
Dept.: PA-VP	Nr. 36-7697			
Up date: xx/xx	Replaces: xxxxxx/ 36-xxxx			Sheet 2
MB-8U2	Scale:			of 2

PEPPERL+FUCHS
Mannheim-Schönau

Motherboard unit
Digital Input (Pulse)
8 channels
ISTA-TR-DI-SOT-3511-.....

5. 3604E / 3624 Application

(16 channels DO)

	Page
Simplified schematic 3604E / 3624	5- 1
Motherboard ISTA-TR-DO-SD-36XX-118274	5- 2
Part No.:	118274
Function:	Digital Output
Channels:	16
System cable:	(ELCO connector)
KF- Module:	KFD2-SD-Ex1.48... (single channel)
Simplified schematic:	drawing no. 36-9284
Wiring Diagram:	drawing no. 36-7430
Simplified schematic 3604E	5- 5
Motherboard ISTA-TR-DO-SL2-36XX-118273	5- 6
Part No.:	118273
Function:	Digital Output
Channels:	16
System cable:	(ELCO connector)
KF- Module:	KFD2-SL2-Ex2.B (dual channel)
Simplified schematic:	drawing no. 36-9285
Wiring Diagram:	drawing no. 36-7363
Motherboard ISTA-TR-DO-SL2-36XX-118288	5- 8
Part No.:	118288
Function:	Digital Output
Channels:	16
System cable:	(ELCO connector)
KF- Module:	KFD2-SL2-Ex2 (dual channel)
Simplified schematic:	drawing no. 36-9285
Wiring Diagram:	drawing no. 36-7358

3604E DIGITAL OUTPUT MODULE

Simplified schematic of a typical 16-point digital output module
(1 of 16 points shown)

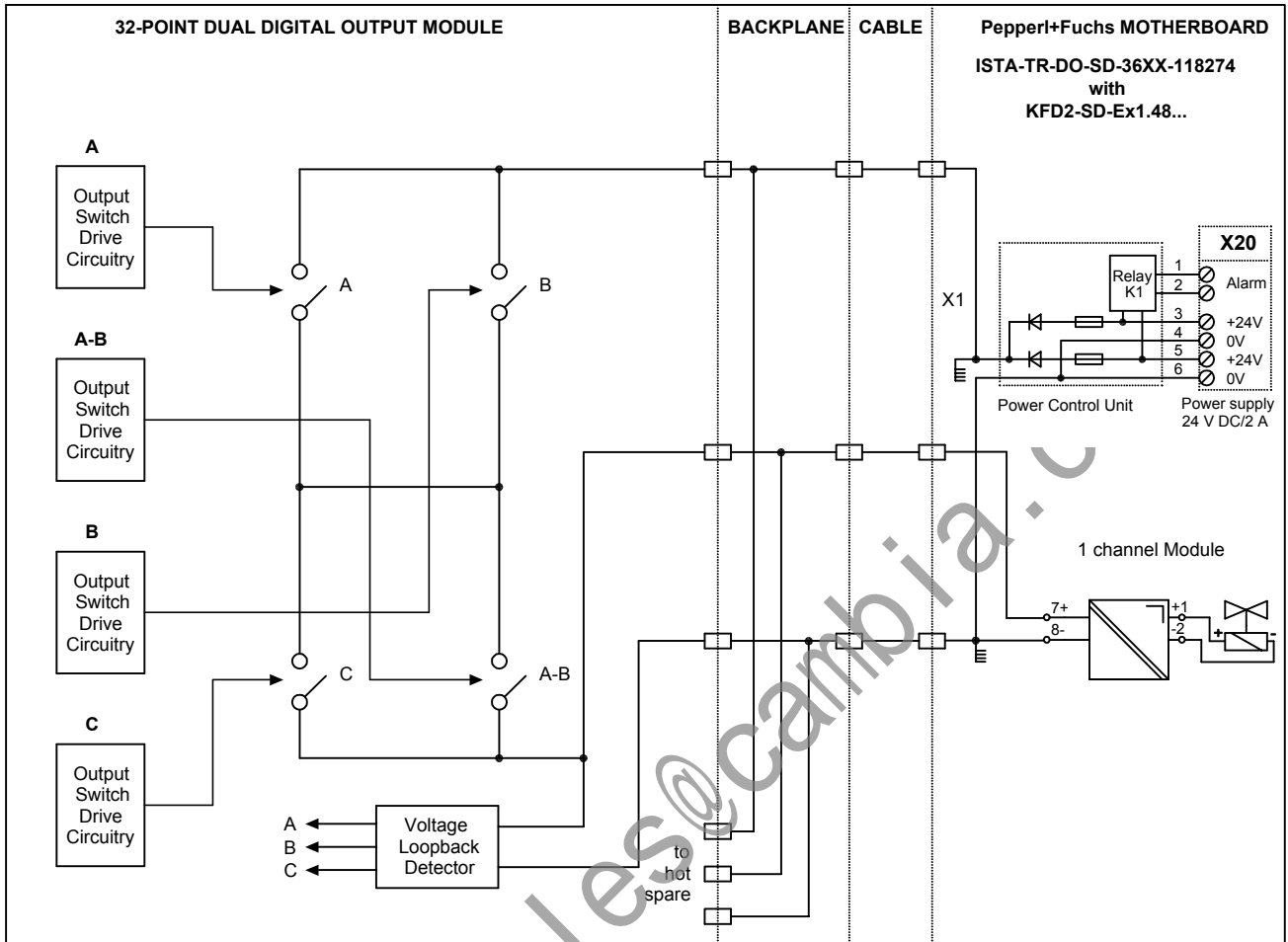

Pin assignment of connector #A (56 pin ELCO female)

Pin	AA	KK	LL	z	DD	EE	p	u	v	h	k	l	e	a
Signal	PWR1	LOAD1	RTN1	PWR2	LOAD2	RTN2	PWR3	LOAD3	RTN3	PWR4	LOAD4	RTN4	PWR5	LOAD5
Pin	b	W	R	S	L	E	F	M	A	B	BB	NN	MM	CC
Signal	RTN5	PWR6	LOAD6	RTN6	PWR7	LOAD7	RTN7	PWR8	LOAD8	RTN8	PWR9	LOAD9	RTN9	PWR10
Pin	JJ	HH	t	y	x	j	n	m	f	d	c	Z	V	U
Signal	LOAD10	RTN10	PWR11	LOAD11	RTN11	PWR12	LOAD12	RTN12	PWR13	LOAD13	RTN13	PWR14	LOAD14	RTN14
Pin	P	K	J	N	D	C	T	H	w	FF	r	s	X	Y
Signal	PWR15	LOAD15	RTN15	PWR16	LOAD16	RTN16	CGND	CGND	CGND	CGND	**	**	**	**

** not used	CGND is the chassis ground	02.03.99	AJ	AJ	--	
		Date	S TZ	Off. in ch.	contr. techn.	contr. Norm

PEPPERL+FUCHS Mannheim-Schönau	D-TR-3604E	Dept.: PA-VP	Nr. 36-9284
		vB/Bro	Replaces: XXXXX / 36-XXXX
		Up date: 22.03.04	Sheet 1
		Scale: - : -	of 1

copyright according to DIN34
unauthorized distribution and reproduction prohibited

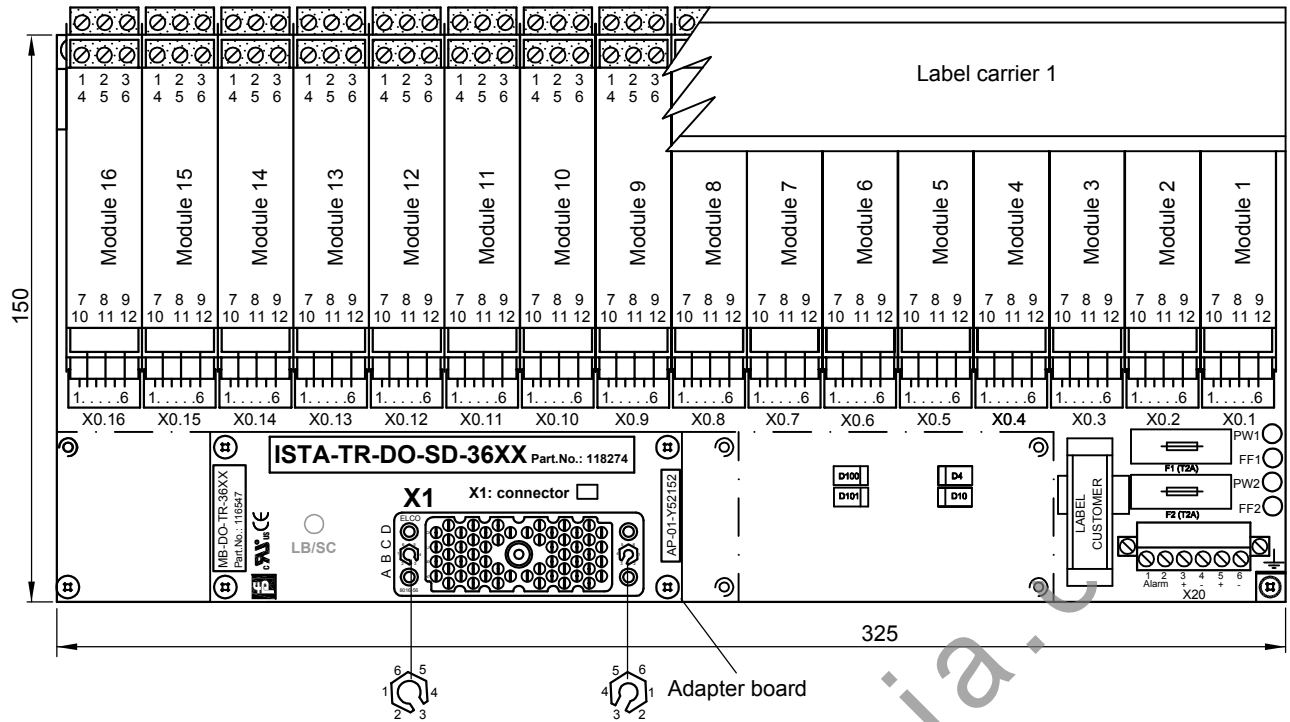

APPLICATION:
TRICONEX I/O card 3604E:
 16 points, non commoned

Motherboard 1: connected with connector #A
 Module 1 ... 16, channels 1 ... 16

APPLICATION:
TRICONEX I/O card 3664: will be required 2 x ISTA-TR-DO-SD-36XX-118274
 16 + 16 points, non commoned, diff., DC coupled

Motherboard 2: connected with connector #B
 Module 1 ... 16, channels 1 ... 16

Motherboard 1: connected with connector #A
 Module 1 ... 16, channels 1 ... 16

Name	Note
X1	56 pin female system connector ELCO (small key: 3, large key: 3)
----	----
X0.1 16	6 pin male terminals for cable tree FSY....
X20.3 6	Power supply screw terminals
X20.1, X20.2	Alarm screw terminal
F1, F2	Fuse
PW1, PW2, FF1, FF2	LEDs for power and power failure

Ordering information: ISTA-TR-DO-SD-36XX-118274		
Basic components:	Description	
16 pieces:	KFD2-SD-Ex1.48... (DO)	KF-Module type (function)
1 piece:	MB-DO-TR-36XX-116547	Motherboard without modules
composed by:		
1 piece:	MB-16U5L-103681	Motherboard without modules, adapter board, FSY cable tree and Label carrier
1 piece:	AP-01-Y52152	Adapter board
1 piece:	KFD0-LC1-16M-99144	Label carrier 1
16 pieces:	FSY-L450-98833	Cable tree connection KF-Module-Motherboard

copyright according to DIN34 unauthorized distribution and reproduction prohibited

	PEPPERL+FUCHS Mannheim-Schönau	Motherboard unit Digital Output 16 channels ISTA-TR-DO-SD-36XX	21.03.02	KT	vB	vB/Sb		
			Date	S	TZ	Off. in ch.	contr. techn.	contr. Norm
			Dept.:	PA-VP	Nr. 36-7430			
			Up date:	vB/Bro 22.03.04	Replaces:	116547 / 36-7621	Sheet	1
	MB-16U5L	Scale:	1 : 2 (1 : 8)	of	3			

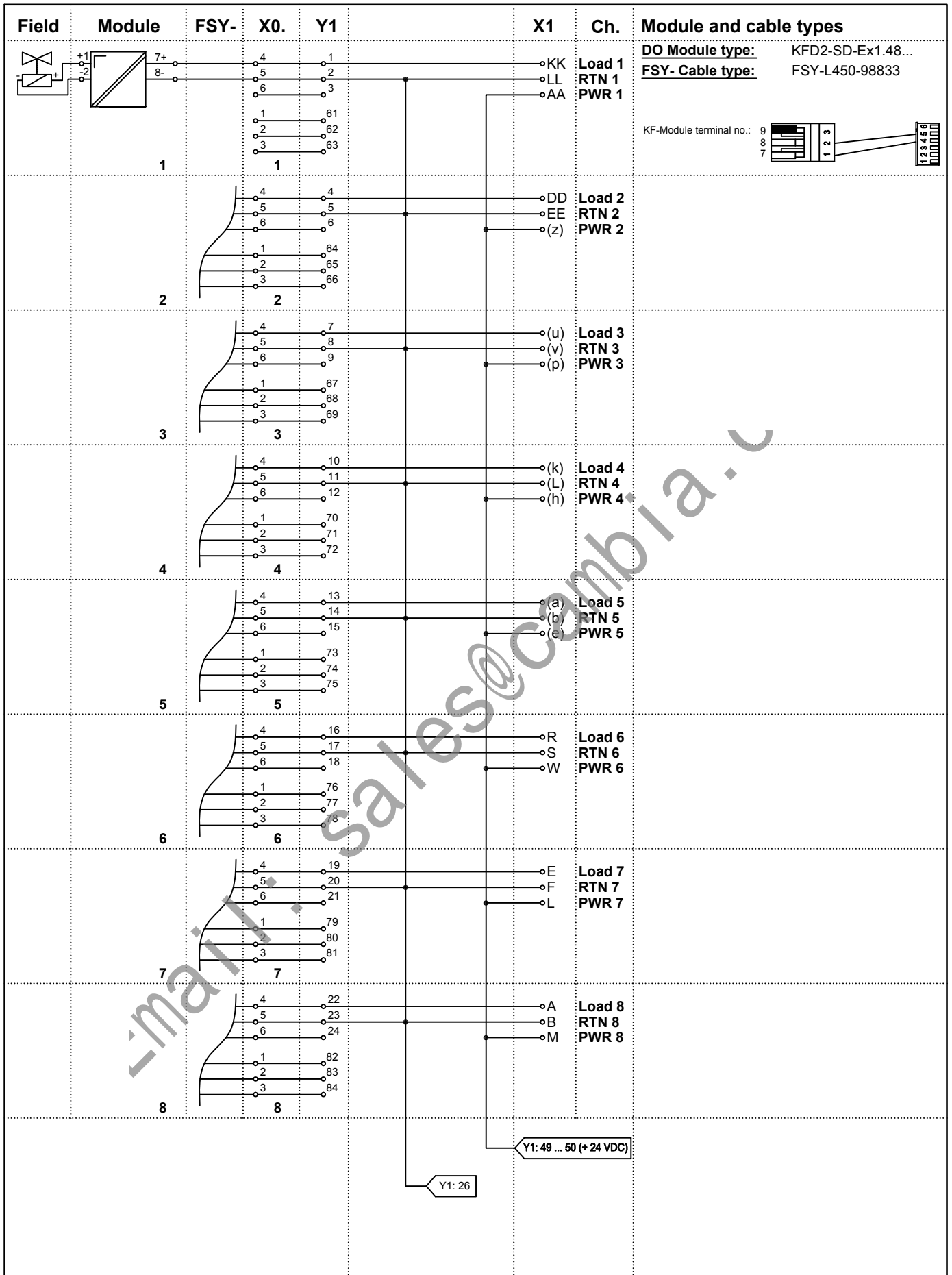

copyright according to DIN34
 unauthorized distribution and reproduction prohibited

	PEPPERL+FUCHS Mannheim-Schönau	Motherboard unit Digital Output 16 channels ISTA-TR-DO-SD-36XX	21.03.02		KT	vB	vB/Sb			
			Date	S	TZ	Off. in ch.	contr. techn.	contr. Norm		
			Dept.:	PA-VP		Nr. 36-7430				
			Up date:	vB/Bro 22.03.04		Replaces: 116547 / 36-7621		Sheet 2		
		MB-16U5L	Scale:			of 3				

copyright according to DIN34
 unauthorized distribution and reproduction prohibited

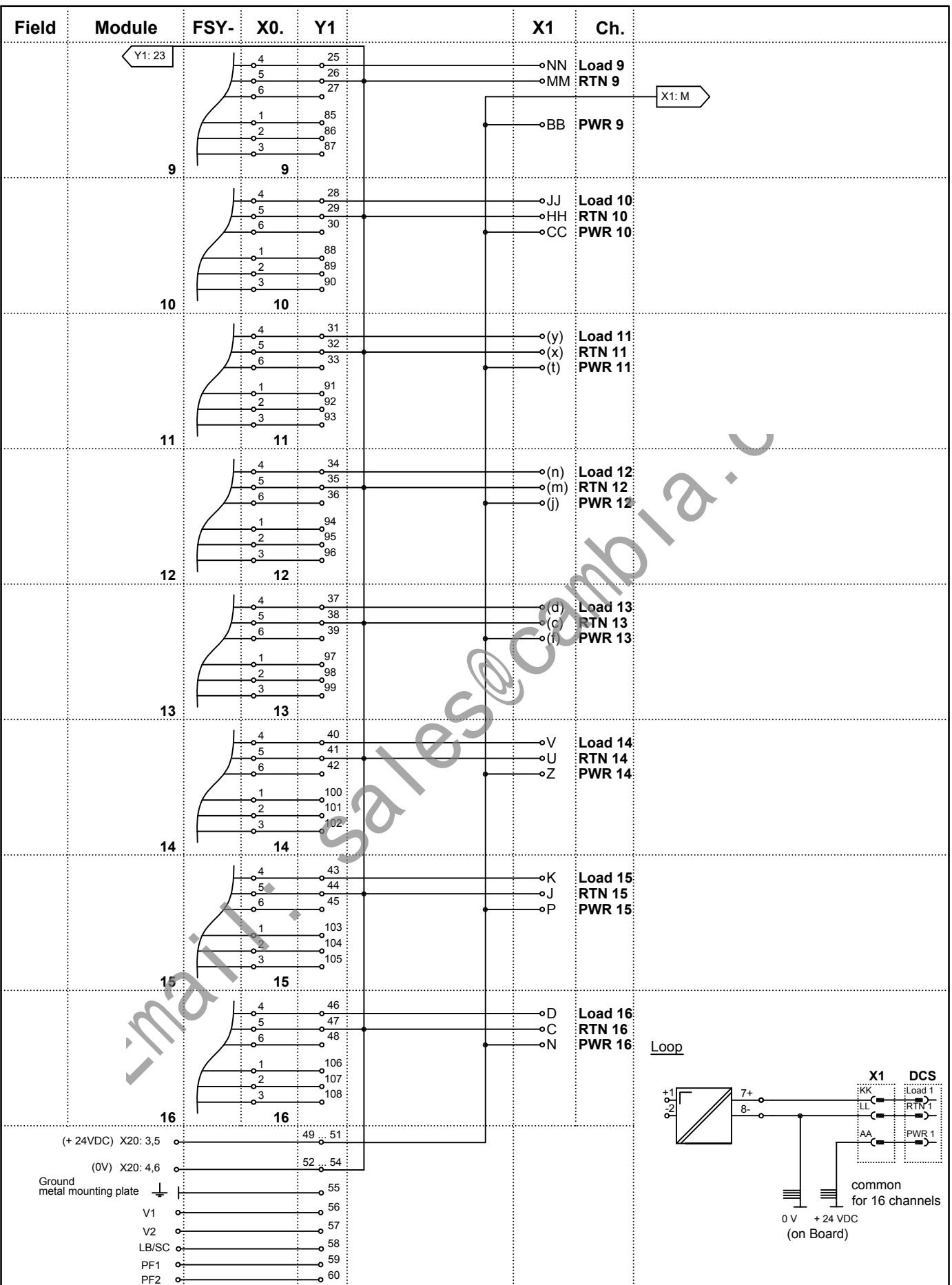

Note: Letters in brackets are small letters



Motherboard unit
 Digital Output
 16 channels
 ISTA-TR-DO-SD-36XX

21.03.02		KT	vB	vB/Sb	
Date	S	TZ	Off. in ch.	contr. techn.	contr. Norm
Dept.: PA-VP	vB/Bro		Nr. 36-7430		
Up date: 22.03.04	Replaces: 116547 / 36-7621				Sheet 3
MB-16U5L	Scale:				of 3

3604E DIGITAL OUTPUT MODULE

Simplified schematic of a typical 16-point digital output module
(1 of 16 points shown)

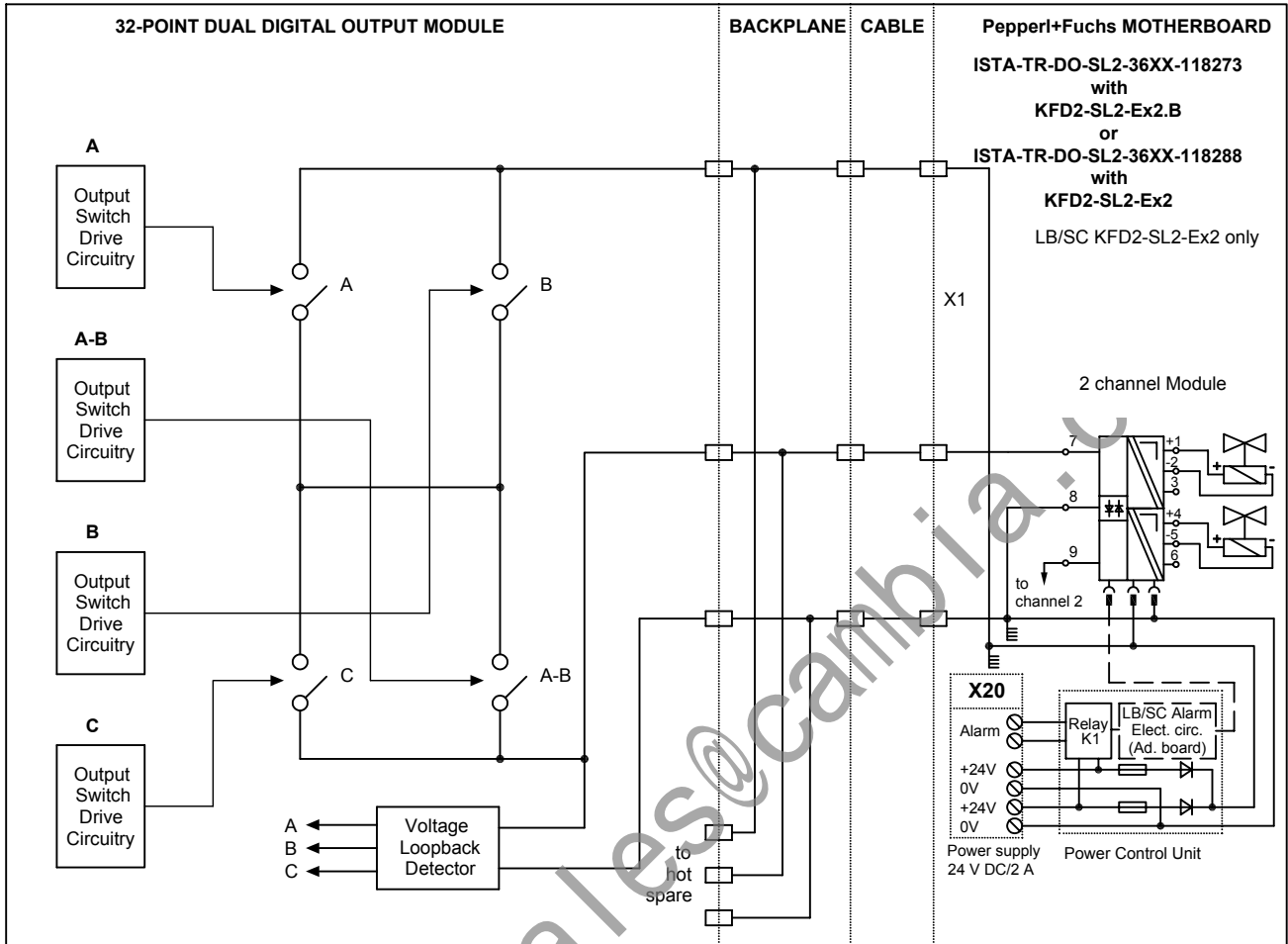

Pin assignment of connector #A (56 pin ELCO female)

Pin	AA	KK	LL	z	DD	EE	p	u	v	h	k	l	e	a
Signal	PWR1	LOAD1	RTN1	PWR2	LOAD2	RTN2	PWR3	LOAD3	RTN3	PWR4	LOAD4	RTN4	PWR5	LOAD5
Pin	b	W	R	S	L	E	F	M	A	B	BB	NN	MM	CC
Signal	RTN5	PWR6	LOAD6	RTN6	PWR7	LOAD7	RTN7	PWR8	LOAD8	RTN8	PWR9	LOAD9	RTN9	PWR10
Pin	JJ	HH	t	y	x	j	n	m	f	d	c	Z	V	U
Signal	LOAD10	RTN10	PWR11	LOAD11	RTN11	PWR12	LOAD12	RTN12	PWR13	LOAD13	RTN13	PWR14	LOAD14	RTN14
Pin	P	K	J	N	D	C	T	H	w	FF	r	s	X	Y
Signal	PWR15	LOAD15	RTN15	PWR16	LOAD16	RTN16	CGND	CGND	CGND	CGND	**	**	**	**

** not used

CGND is the chassis ground

02.03.99	AJ	AJ	- -	
Date	S	TZ	Off. in ch.	contr. techn.

PF
PEPPERL+FUCHS
Mannheim-Schönau

D-TR-3604E

Dept.: PA-VP	Nr. 36-9285A
vB Up date: 07.05.07	Replaces: XXXXX / 36-XXXX
Scale: - : -	Sheet 1 of 1

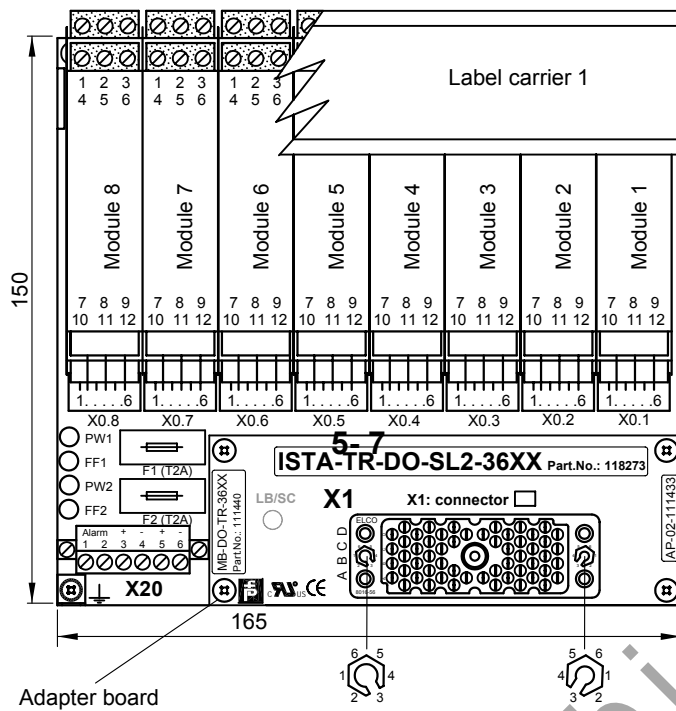

APPLICATION:

TRICONEX I/O card 3604E
16 points, non commoned

Motherboard 1: connected with connector #A
Module 1 ... 8, channels 1 ... 16

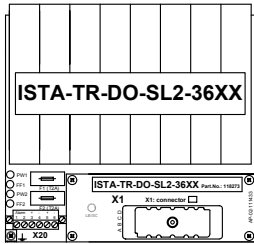

connector #A

APPLICATION:

TRICONEX I/O card 3664: will be required 2 x ISTA-TR-DO-SL2-36XX-118273
32 points, non commoned

Motherboard 2: connected with connector #B
Module 1 ... 8, channels 17 ... 32

Motherboard 1: connected with connector #A
Module 1 ... 8, channels 1 ... 16

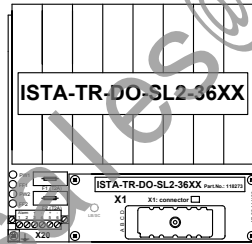

connector #B

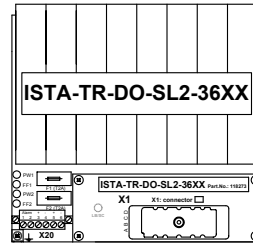

connector #A

Name	Note
X1	56 pin female system connector ELCO (small key: 3, large key: 3)
----	----
X0.1 16	6 pin male terminals for cable tree FSY....
X20.3 6	Power supply screw terminals
X20.1, X20.2	Alarm screw terminal
F1, F2	Fuse
PW1, PW2, FF1, FF2	LEDs for power and power failure

Ordering information: ISTA-TR-DO-SL2-36XX-118273

Basic components:	Description
8 pieces: KFD2-SL2-Ex2.B (DO)	KF-Module type (function)
1 piece: MB-DO-TR-36XX-111440	Motherboard without modules
composed by:	
1 piece: MB-8U2-Y97680	Motherboard without modules, adapter board, FSY cable tree and Label carrier
1 piece: AP-02-111433	Adapter board
1 piece: KFD0-LC1-8M-99143	Label carrier 1
8 pieces: FSY-L456-98837	Cable tree connection KF-Module-Motherboard

copyright according to DIN34
unauthorized distribution and reproduction prohibited

	Motherboard unit Digital Output 16 channels ISTA-TR-DO-SL2-36XX	21.03.02	KT	vB	vB/Sb	
		Date	S TZ	Off. in ch.	contr. techn.	contr. Norm
		Dept.: PA-VP	Nr. 36-7363B			
		Up date: 04.05.07	Replaces: XXXXXX/ 36-XXXX		Sheet 1	
		MB-8U2	Scale: 1 : 2 (1 : 5)		of 2	

copyright according to DIN34
 unauthorized distribution and reproduction prohibited

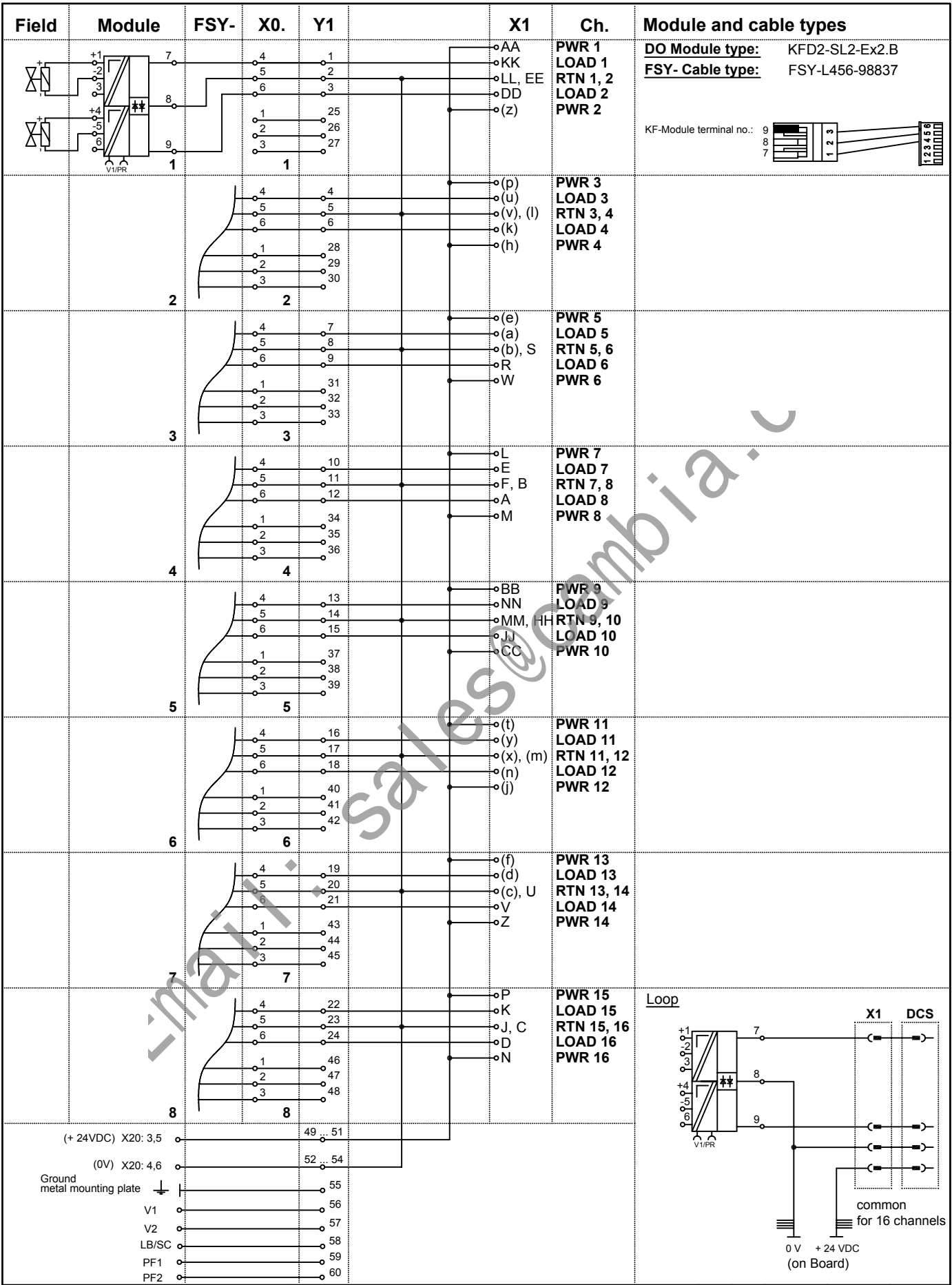

Note: Letters in brackets are small letters

PEPPERL+FUCHS
 Mannheim-Schönau

Motherboard unit
 Digital Output
 16 channels
ISTA-TR-DO-SL2-36XX

21.03.02		KT	vB	vB/Sb	
Date	S	TZ	Off. in ch.	contr. techn.	contr. Norm
Dept.: PA-007	vB		Nr. 36-7363B		
Up date:	Replaces: XXXXXX/ 36-XXXX		Sheet 2		
MB-8U2	Scale: - - -		of 2		

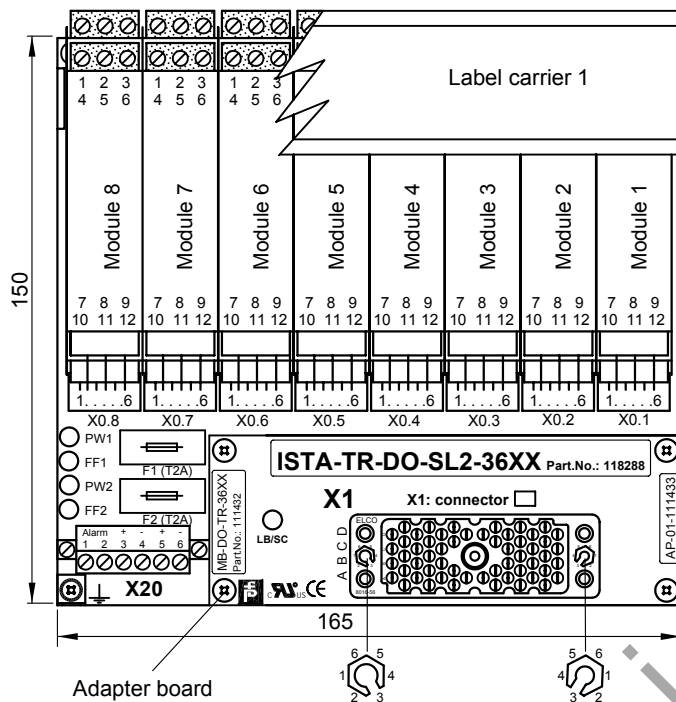

APPLICATION:

TRICONEX I/O card 3604E
16 points, non commoned

Motherboard 1: connected with connector #A
Module 1 ... 8, channels 1 ... 16

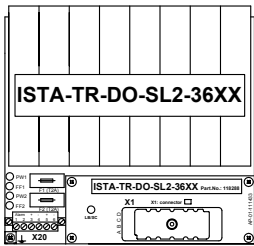

connector #A

APPLICATION:

TRICONEX I/O card 3664: will be required 2 x ISTA-TR-DO-SL2-36XX-118288
32 points, non commoned

Motherboard 2: connected with connector #B
Module 1 ... 8, channels 17 ... 32

Motherboard 1: connected with connector #A
Module 1 ... 8, channels 1 ... 16

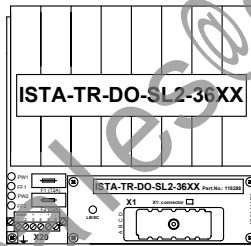

connector #B

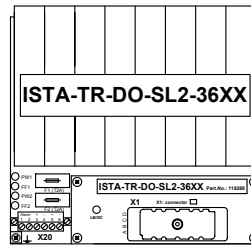

connector #A

Name	Note
X1	56 pin female system connector ELCO (small key: 3, large key: 3)
-----	-----
X0.1 16	6 pin male terminals for cable tree FSY....
X20.3 6	Power supply screw terminals
X20.1, X20.2	Alarm screw terminal
F1, F2	Fuse
PW1, PW2, FF1, FF2	LEDs for power and power failure
Power Rail	PR-03 (with 3 conductors)

Ordering information: ISTA-TR-DO-SL2-36XX-118288

Basic components:	Description
8 pieces:	KFD2-SL2-Ex2 (DO) KF-Module type (function)
1 piece:	MB-DO-TR-36XX-111432 Motherboard without modules
composed by:	
1 piece:	MB-8U2-Y97680 Motherboard without modules, adapter board, FSY cable tree and Label carrier
1 piece:	AP-01-111433 Adapter board
1 piece:	KFD0-LC1-8M-99143 Label carrier 1
8 pieces:	FSY-L456-98837 Cable tree connection KF-Module-Motherboard

copyright according to DIN34
unauthorized distribution and reproduction prohibited

	Motherboard unit Digital Output 16 channels - LB/SC monitoring ISTA-TR-DO-SL2-36XX	21.03.02	KT	vB	vB/Sb		
		Date	S	TZ	Off. in ch.	contr. techn.	contr. Norm
		Dept.: PA-VP	Nr. 36-7358A				
	Up date: 04.05.07	Replaces: XXXXXX/ 36-XXXX		Sheet 1			
	MB-8U2	Scale: 1 : 2, 1 : 5		of 2			

copyright according to DIN34
 unauthorized distribution and reproduction prohibited

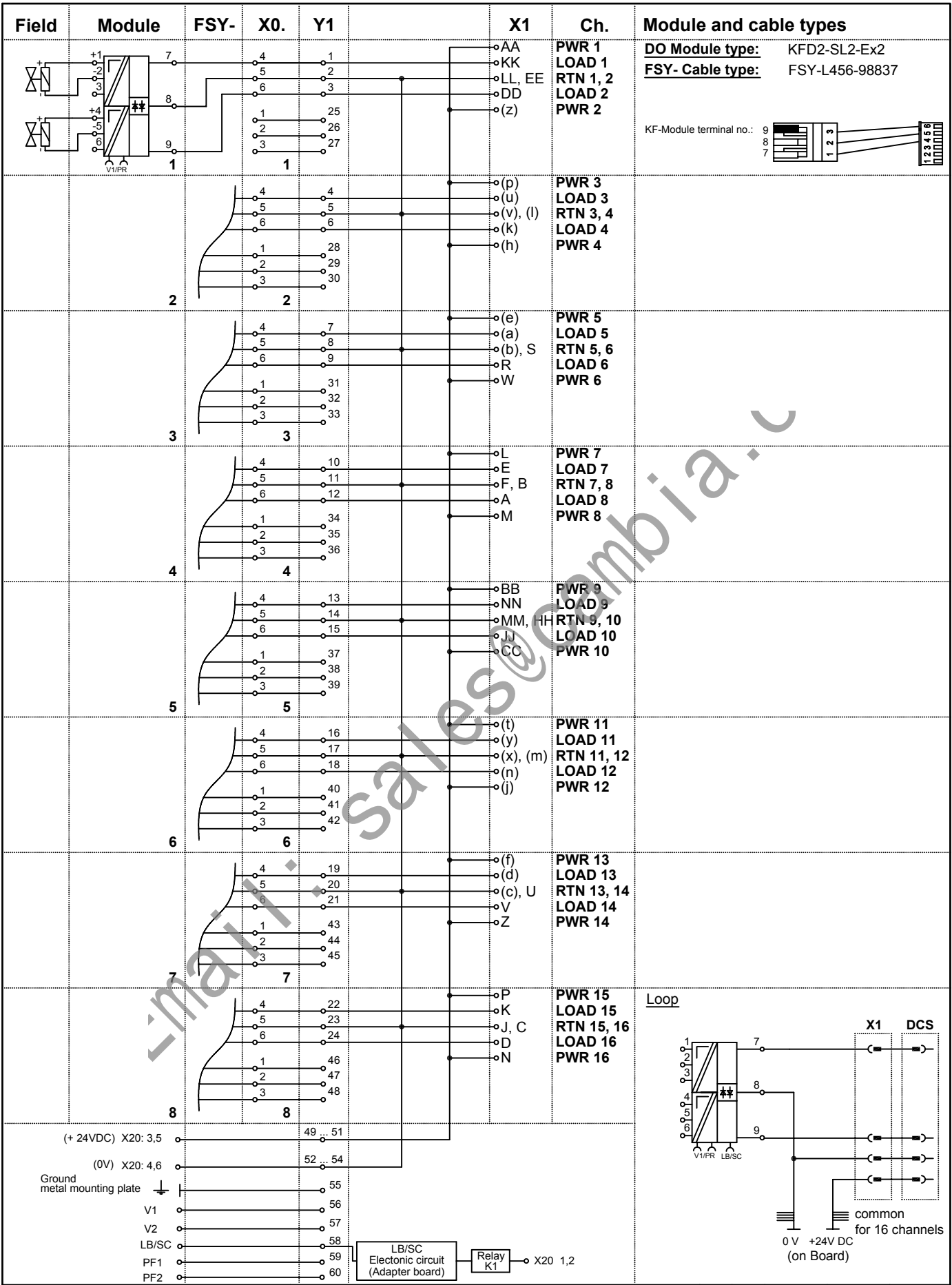

Note: Letters in brackets are small letters

PEPPERL+FUCHS
 Mannheim-Schönau

Motherboard unit
 Digital Output
 16 channels - LB/SC monitoring
ISTA-TR-DO-SL2-36XX

21.03.02		KT	vB	vB/Sb	
Date	S	TZ	Off. in ch.	contr. techn.	contr. Norm
Dept.: PA-VP	Nr. 36-7358A		Replaces: XXXXXX/ 36-XXXX		
Up date: 04.05.07	Scale: - - -		Sheet 2 of 2		

6. 3664 Application

(16 + 16 channels DO)

	Page
Simplified schematic 3664	6- 1
2 x Motherboard ISTA-TR-DO-SD-36XX-118274	6- 2
Part No.:	118274
Function:	Digital Output
Channels:	16
System cable:	(ELCO connector)
KF- Module:	KFD2-SD-Ex1.48... (single channel)
Simplified schematic:	drawing no. 36-9286
Wiring Diagram:	drawing no. 36-7430
Simplified schematic 3664	6- 5
2 x Motherboard ISTA-TR-DO-SL2-36XX-118273	6- 6
Part No.:	118273
Function:	Digital Output
Channels:	16
System cable:	(ELCO connector)
KF- Module:	KFD2-SL2-Ex2.B (dual channel)
Simplified schematic:	drawing no. 36-9287
Wiring Diagram:	drawing no. 36-7363
2 x Motherboard ISTA-TR-DO-SL2-36XX-118288	6- 8
Part No.:	118288
Function:	Digital Output
Channels:	16
System cable:	(ELCO connector)
KF- Module:	KFD2-SL2-Ex2 (dual channel)
Simplified schematic:	drawing no. 36-9287
Wiring Diagram:	drawing no. 36-7358

3664 DIGITAL OUTPUT MODULE

Simplified schematic of a typical 32-point commoned dual DC digital output module with self protection (1 of 32 points shown)

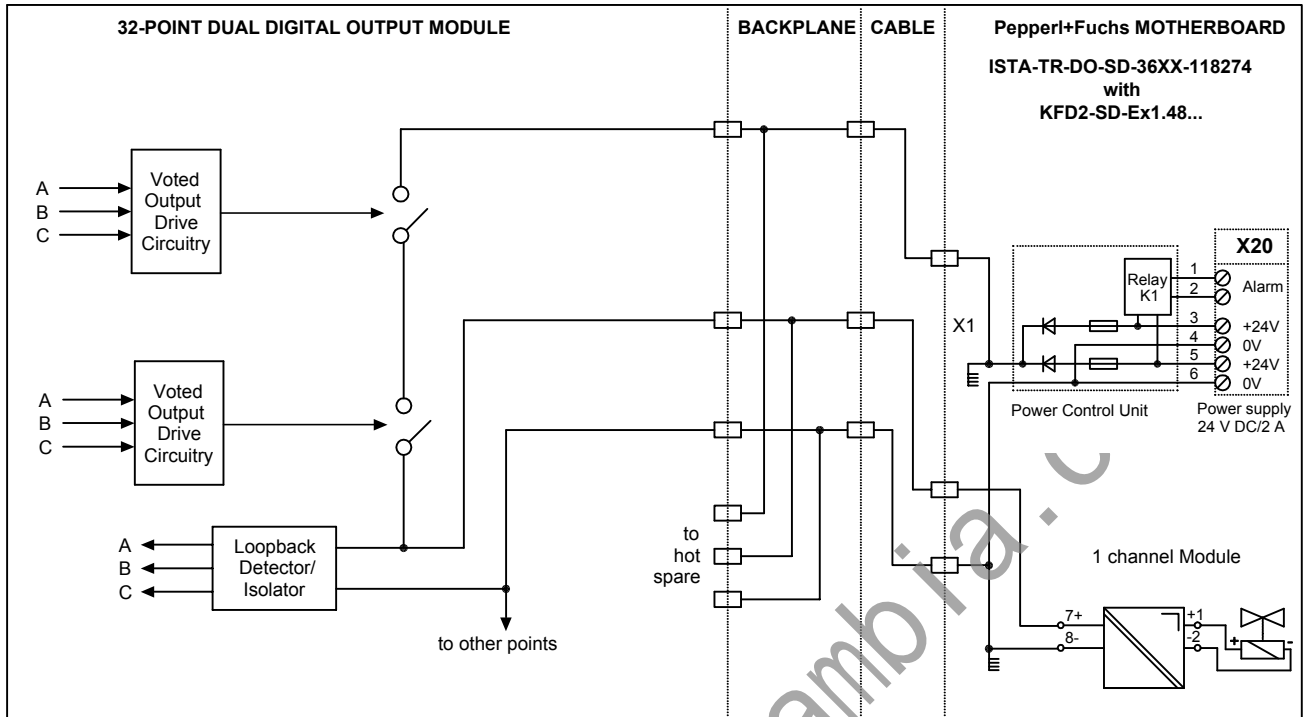

Pin assignment of connector #A (56 pin ELCO female)

Pin	AA	KK	LL	z	DD	EE	p	u	v	h	k	l	e	a
Signal	PWR1	LOAD1	RTN1	PWR2	LOAD2	RTN2	PWR3	LOAD3	RTN3	PWR4	LOAD4	RTN4	PWR5	LOAD5
Pin	b	W	R	S	L	E	F	M	A	B	BB	NN	MM	CC
Signal	RTN5	PWR6	LOAD6	RTN6	PWR7	LOAD7	RTN7	PWR8	LOAD8	RTN8	PWR9	LOAD9	RTN9	PWR10
Pin	JJ	HH	t	y	x	j	n	m	f	d	c	Z	V	U
Signal	LOAD10	RTN10	PWR11	LOAD11	RTN11	PWR12	LOAD12	RTN12	PWR13	LOAD13	RTN13	PWR14	LOAD14	RTN14
Pin	P	K	J	N	D	C	T	H	w	FF	r	s	X	Y
Signal	PWR15	LOAD15	RTN15	PWR16	LOAD16	RTN16	CGND	CGND	CGND	CGND	**	**	**	**

Pin assignment of connector #B (56 pin ELCO female)

Pin	AA	KK	LL	z	DD	EE	p	u	v	h	k	l	e	a
Signal	PWR17	LOAD17	RTN17	PWR18	LOAD18	RTN18	PWR19	LOAD19	RTN19	PWR20	LOAD20	RTN20	PWR21	LOAD21
Pin	b	W	R	S	L	E	F	M	A	B	BB	NN	MM	CC
Signal	RTN21	PWR22	LOAD22	RTN22	PWR23	LOAD23	RTN23	PWR24	LOAD24	RTN24	PWR25	LOAD25	RTN25	PWR26
Pin	JJ	HH	t	y	x	j	n	m	f	d	c	Z	V	U
Signal	LOAD26	RTN26	PWR27	LOAD27	RTN27	PWR28	LOAD28	RTN28	PWR29	LOAD29	RTN29	PWR30	LOAD30	RTN30
Pin	P	K	J	N	D	C	T	H	w	FF	r	s	X	Y
Signal	PWR31	LOAD31	RTN31	PWR32	LOAD32	RTN32	CGND	CGND	CGND	CGND	**	**	**	**

** not used

CGND is the chassis ground

21.07.99	AJ	AJ	--	
Date	S TZ	Off. in ch.	contr. techn.	contr. Norm



D-TR-3664

Dept.: PA-VP	Nr. 36-9286
vB/Bro	Replaces: XXXXXX / 36-XXXX
Up date: 23.03.04	Sheet 1
Scale: - : -	of 1

copyright according to DIN34
unauthorized distribution and reproduction prohibited

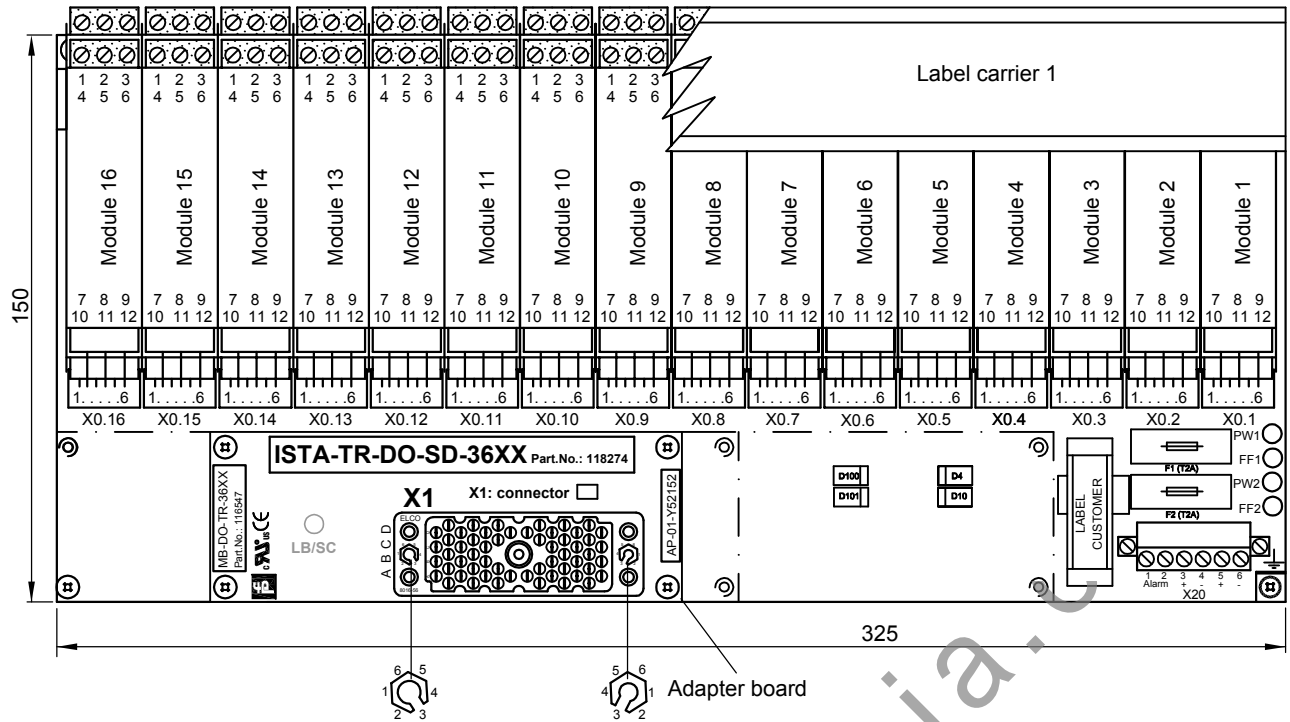

APPLICATION:
TRICONEX I/O card 3604E:
 16 points, non commoned

Motherboard 1: connected with connector #A
 Module 1 ... 16, channels 1 ... 16

APPLICATION:
TRICONEX I/O card 3664: will be required 2 x ISTA-TR-DO-SD-36XX-118274
 16 + 16 points, non commoned, diff., DC coupled

Motherboard 2: connected with connector #B
 Module 1 ... 16, channels 1 ... 16

Motherboard 1: connected with connector #A
 Module 1 ... 16, channels 1 ... 16

Name	Note
X1	56 pin female system connector ELCO (small key: 3, large key: 3)
----	----
X0.1 16	6 pin male terminals for cable tree FSY....
X20.3 6	Power supply screw terminals
X20.1, X20.2	Alarm screw terminal
F1, F2	Fuse
PW1, PW2, FF1, FF2	LEDs for power and power failure

Ordering information: ISTA-TR-DO-SD-36XX-118274		
Basic components:	Description	
16 pieces:	KFD2-SD-Ex1.48... (DO)	KF-Module type (function)
1 piece:	MB-DO-TR-36XX-116547	Motherboard without modules
composed by:		
1 piece:	MB-16U5L-103681	Motherboard without modules, adapter board, FSY cable tree and Label carrier
1 piece:	AP-01-Y52152	Adapter board
1 piece:	KFD0-LC1-16M-99144	Label carrier 1
16 pieces:	FSY-L450-98833	Cable tree connection KF-Module-Motherboard

copyright according to DIN34 unauthorized distribution and reproduction prohibited

	PEPPERL+FUCHS Mannheim-Schönau	Motherboard unit Digital Output 16 channels ISTA-TR-DO-SD-36XX	21.03.02	KT	vB	vB/Sb		
			Date	S	TZ	Off. in ch.	contr. techn.	contr. Norm
			Dept.:	PA-VP	Nr. 36-7430			
			Up date:	vB/Bro 22.03.04	Replaces:	116547 / 36-7621	Sheet	1
	MB-16U5L		Scale:	1 : 2 (1 : 8)	of	3		

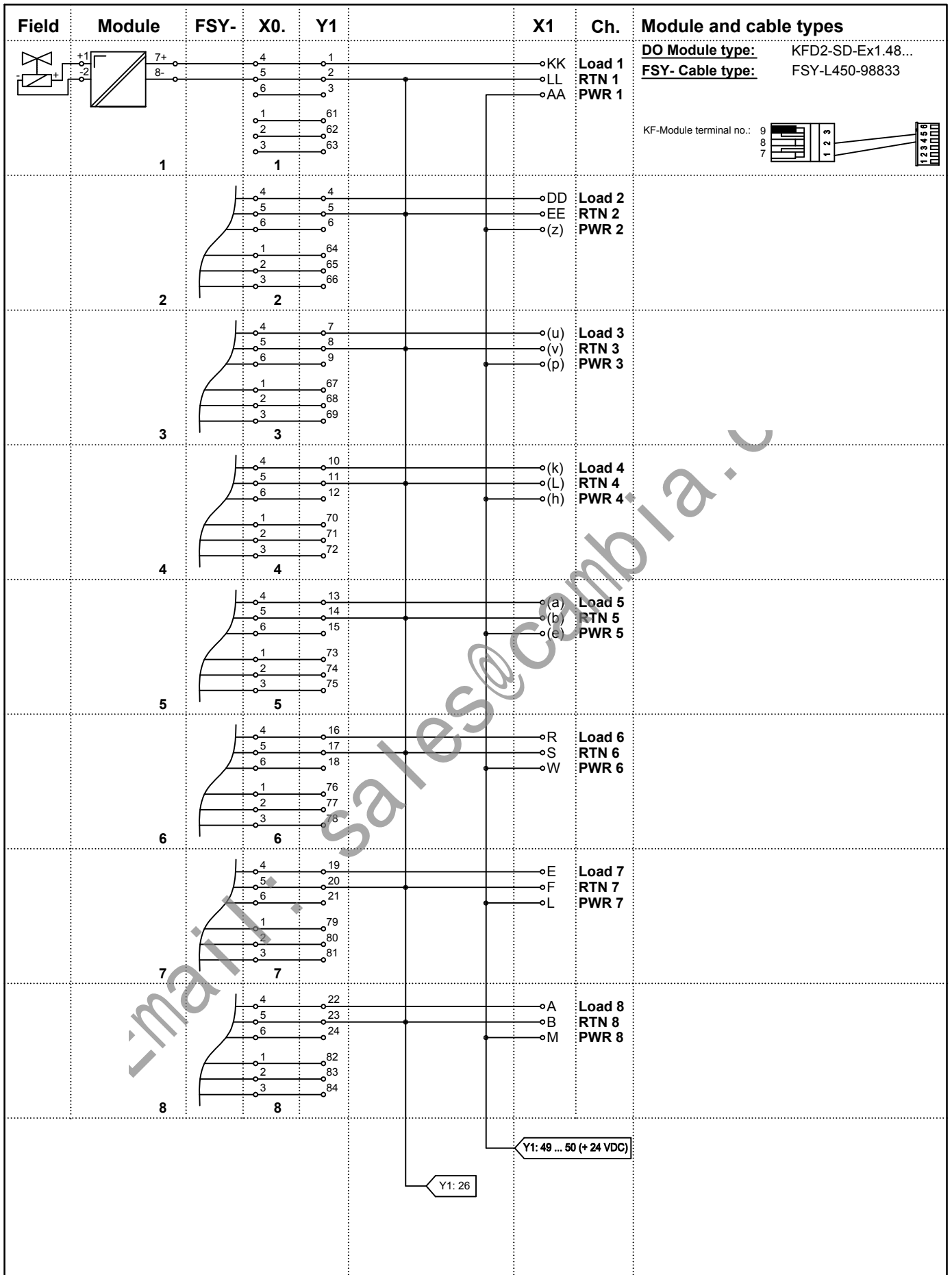

copyright according to DIN34
 unauthorized distribution and reproduction prohibited

	Note: Letters in brackets are small letters				
	21.03.02		KT	vB	vB/Sb
	Date	S	TZ	Off. in ch.	contr. techn.
	Dept.: PA-VP	Nr. 36-7430			
Up date: 22.03.04	vB/Bro		Replaces: 116547 / 36-7621		Sheet 2
MB-16U5L	Scale:				of 3

copyright according to DIN34
 unauthorized distribution and reproduction prohibited

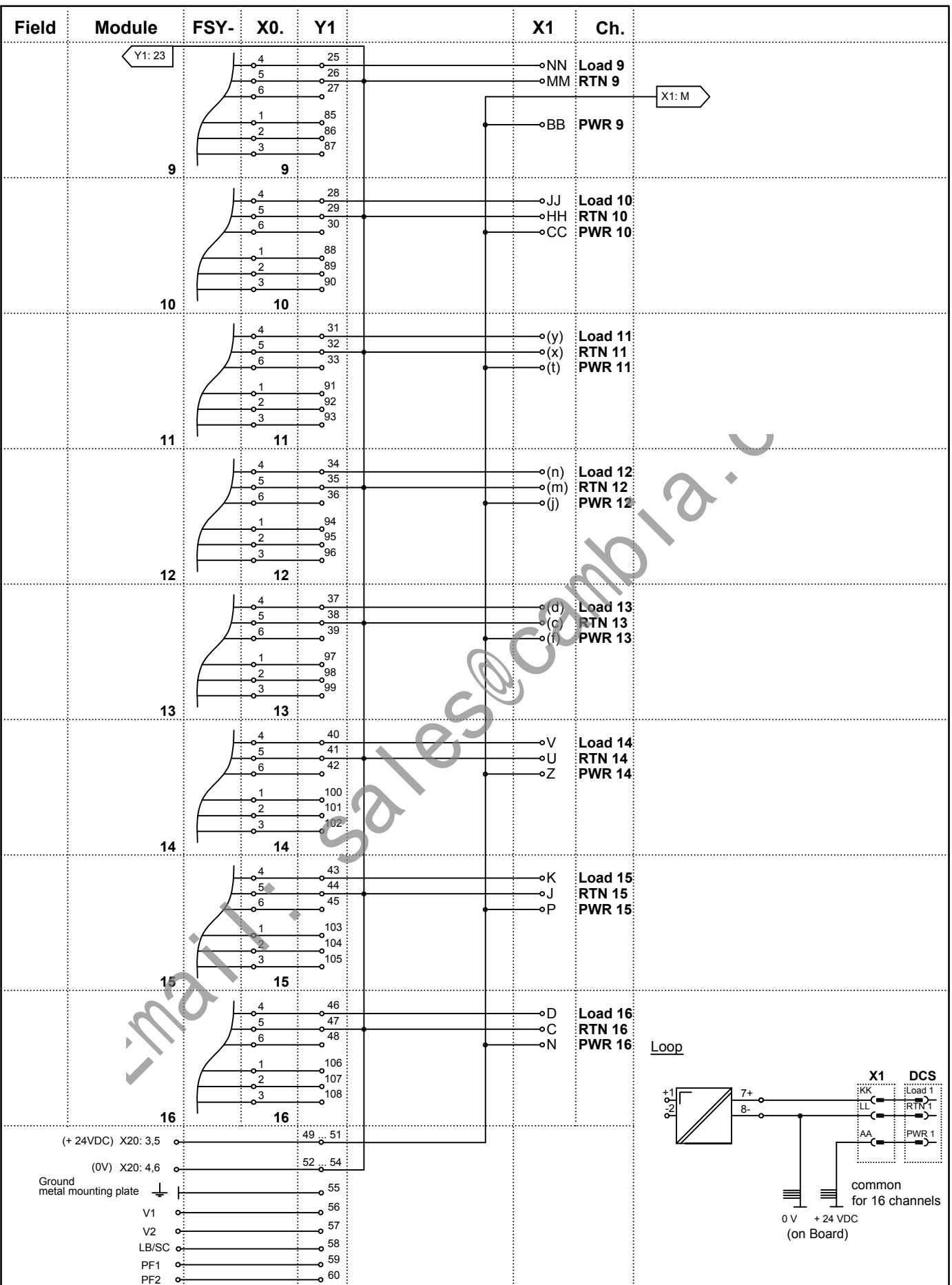

	Note: Letters in brackets are small letters				
	21.03.02		KT	vB	vB/Sb
	Date	S	TZ	Off. in ch.	contr. techn.
	Dept.: PA-VP		Nr. 36-7430		
Up date: vB/Bro 22.03.04		Replaces: 116547 / 36-7621		Sheet 3	
MB-16U5L		Scale:		of 3	

3664 DIGITAL OUTPUT MODULE

Simplified schematic of a typical 32-point commoned dual DC digital output module with self protection (1 of 32 points shown)

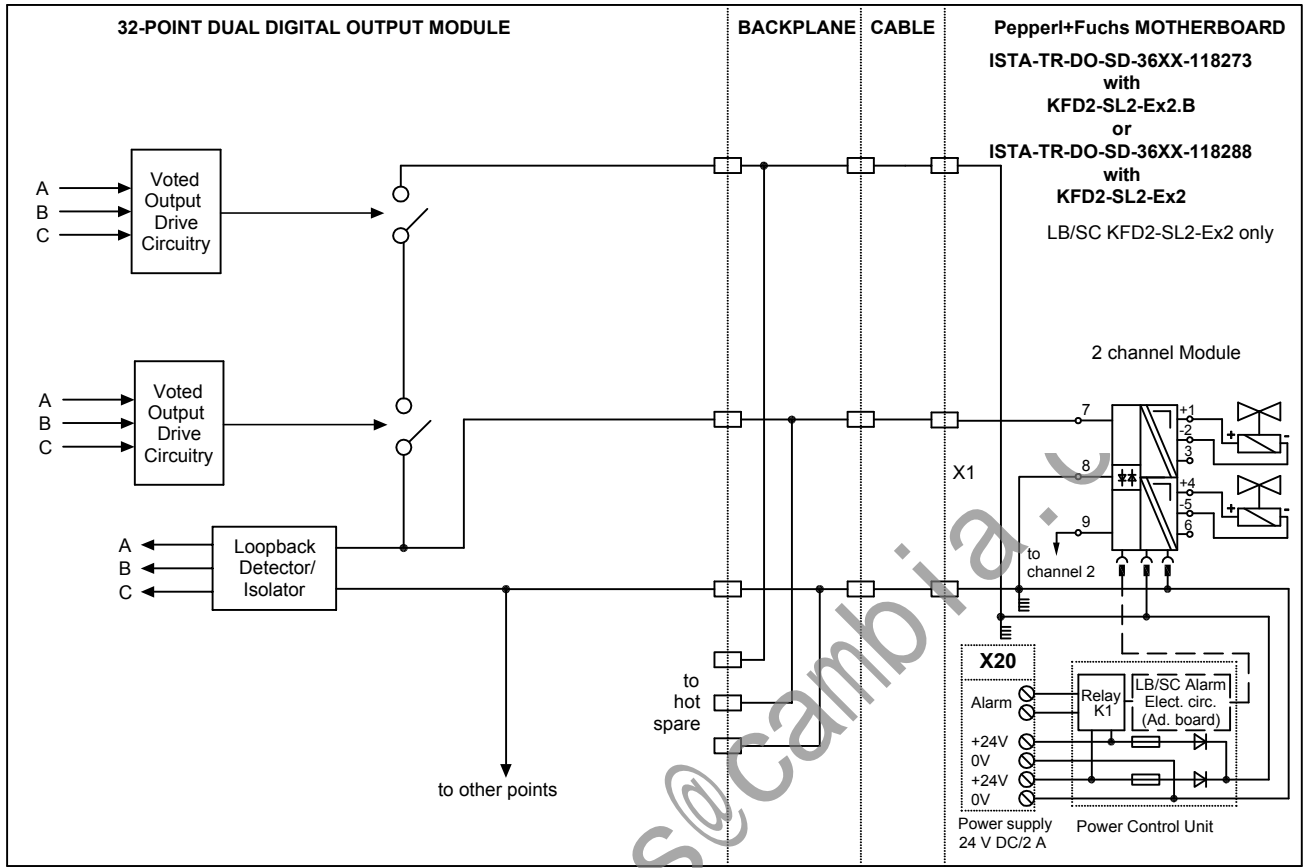

Pin assignment of connector #A (56 pin ELCO female)

Pin	AA	KK	LL	z	DD	EE	p	u	v	h	k	l	e	a
Signal	PWR1	LOAD1	RTN1	PWR2	LOAD2	RTN2	PWR3	LOAD3	RTN3	PWR4	LOAD4	RTN4	PWR5	LOAD5
Pin	b	W	R	S	L	E	F	M	A	B	BB	NN	MM	CC
Signal	RTN5	PWR6	LOAD6	RTN6	PWR7	LOAD7	RTN7	PWR8	LOAD8	RTN8	PWR9	LOAD9	RTN9	PWR10
Pin	JJ	HH	t	y	x	j	n	m	f	d	c	Z	V	U
Signal	LOAD10	RTN10	PWR11	LOAD11	RTN11	PWR12	LOAD12	RTN12	PWR13	LOAD13	RTN13	PWR14	LOAD14	RTN14
Pin	P	K	J	N	D	C	T	H	w	FF	r	s	X	Y
Signal	PWR15	LOAD15	RTN15	PWR16	LOAD16	RTN16	CGND	CGND	CGND	CGND	**	**	**	**

Pin assignment of connector #B (56 pin ELCO female)

Pin	AA	KK	LL	z	DD	EE	p	u	v	h	k	l	e	a
Signal	PWR17	LOAD17	RTN17	PWR18	LOAD18	RTN18	PWR19	LOAD19	RTN19	PWR20	LOAD20	RTN20	PWR21	LOAD21
Pin	b	W	R	S	L	E	F	M	A	B	BB	NN	MM	CC
Signal	RTN21	PWR22	LOAD22	RTN22	PWR23	LOAD23	RTN23	PWR24	LOAD24	RTN24	PWR25	LOAD25	RTN25	PWR26
Pin	JJ	HH	t	y	x	j	n	m	f	d	c	Z	V	U
Signal	LOAD26	RTN26	PWR27	LOAD27	RTN27	PWR28	LOAD28	RTN28	PWR29	LOAD29	RTN29	PWR30	LOAD30	RTN30
Pin	P	K	J	N	D	C	T	H	w	FF	r	s	X	Y
Signal	PWR31	LOAD31	RTN31	PWR32	LOAD32	RTN32	CGND	CGND	CGND	CGND	**	**	**	**

** not used	CGND is the chassis ground	21.07.99		AJ	AJ	--	
		Date	S	TZ	Off. in ch.	contr. techn.	contr. Norm

 PEPPERL+FUCHS Mannheim-Schönau	D-TR-3664	Dept.: PA-VP	Nr. 36-9287	
		vB/Bro	Replaces:	
		Up date: 23.03.04	XXXXX / 36-XXXX	Sheet 1
		Scale:	- : -	of 1

copyright according to DIN34 unauthorized distribution and reproduction prohibited

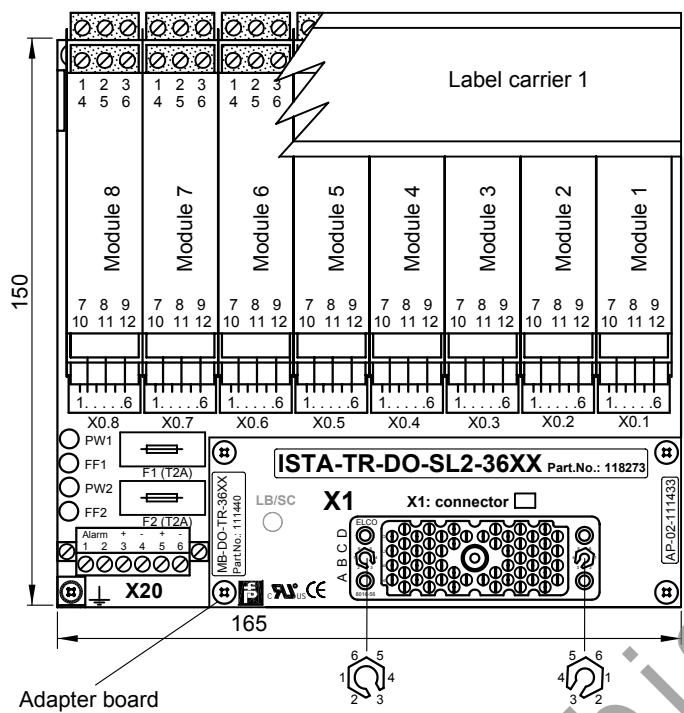

APPLICATION:

TRICONEX I/O card 3604E
16 points, non commoned

Motherboard 1: connected with connector #A
Module 1 ... 8, channels 1 ... 16

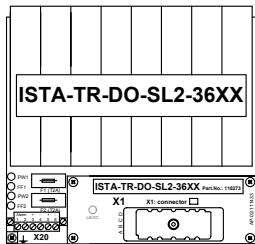

connector #A

APPLICATION:

TRICONEX I/O card 3664: will be required 2 x ISTA-TR-DO-SL2-36XX-118273
32 points, non commoned

Motherboard 2: connected with connector #B
Module 1 ... 8, channels 17 ... 32
Motherboard 1: connected with connector #A
Module 1 ... 8, channels 1 ... 16

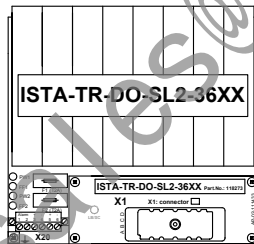

connector #B

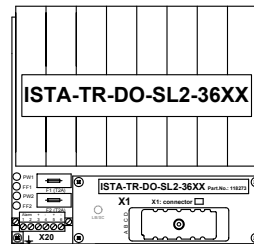

connector #A

Name	Note
X1	56 pin female system connector ELCO (small key: 3, large key: 3)
----	----
X0.1 16	6 pin male terminals for cable tree FSY....
X20.3 6	Power supply screw terminals
X20.1, X20.2	Alarm screw terminal
F1, F2	Fuse
PW1, PW2, FF1, FF2	LEDs for power and power failure

Ordering information: ISTA-TR-DO-SL2-36XX-118273

Basic components:	Description
8 pieces: KFD2-SL2-Ex2.B (DO)	KF-Module type (function)
1 piece: MB-DO-TR-36XX-111440	Motherboard without modules
composed by:	
1 piece: MB-8U2-Y97680	Motherboard without modules, adapter board, FSY cable tree and Label carrier
1 piece: AP-02-111433	Adapter board
1 piece: KFD0-LC1-8M-99143	Label carrier 1
8 pieces: FSY-L456-98837	Cable tree connection KF-Module-Motherboard

copyright according to DIN34
unauthorized distribution and reproduction prohibited

	PEPPERL+FUCHS Mannheim-Schönau	Motherboard unit Digital Output 16 channels ISTA-TR-DO-SL2-36XX	21.03.02	KT	vB	vB/Sb	
			Date	S TZ	Off. in ch.	contr. techn.	contr. Norm
			Dept.: PA-VP	Nr. 36-7363B			
Up date: 04.05.07	Replaces: XXXXXX/ 36-XXXX		Sheet 1				
MB-8U2	Scale: 1 : 2 (1 : 5)		of 2				

copyright according to DIN34
unauthorized distribution and reproduction prohibited

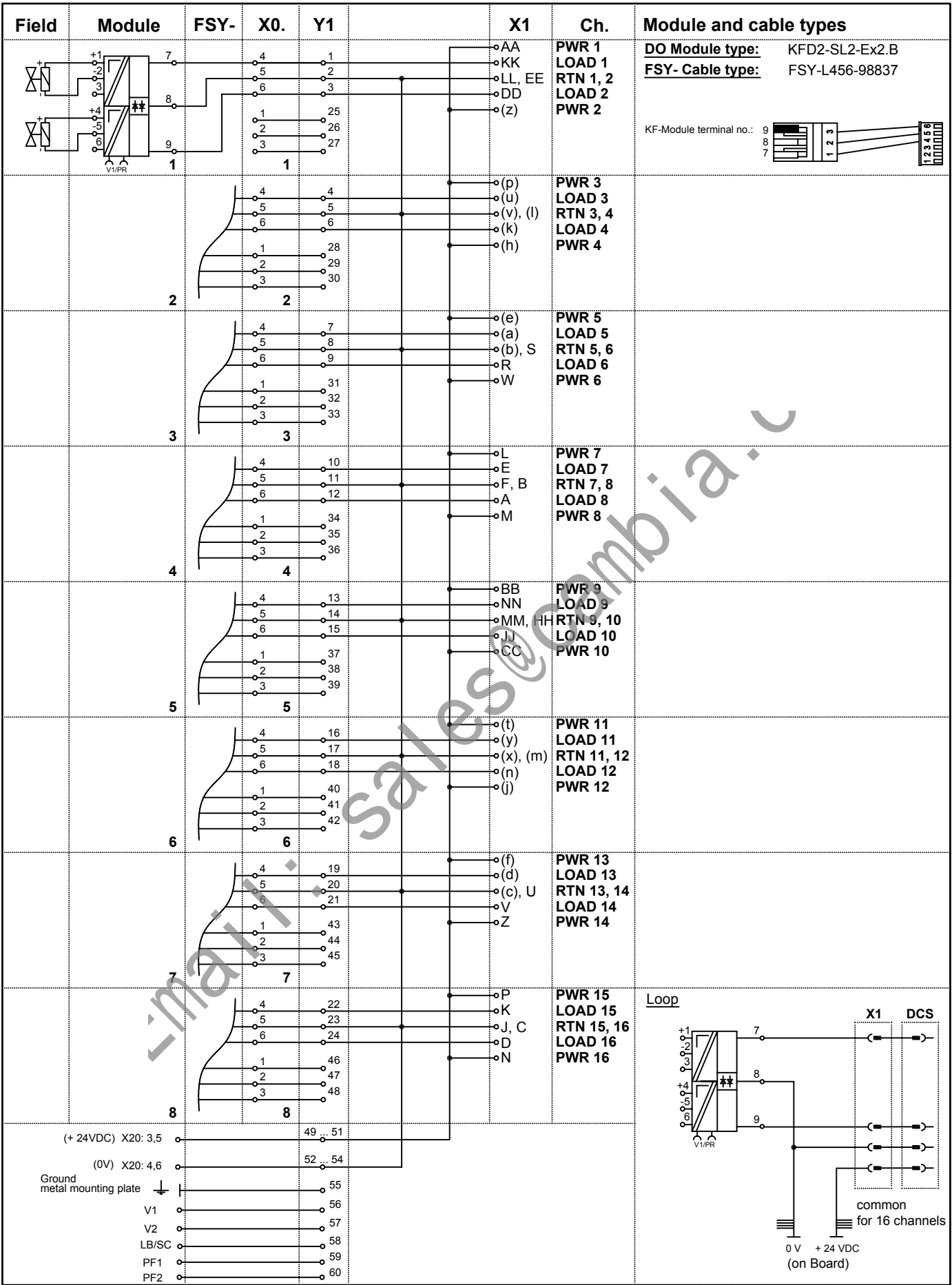

Note: Letters in brackets are small letters

PEPPERL+FUCHS
Mannheim-Schönau

Motherboard unit
Digital Output
16 channels
ISTA-TR-DO-SL2-36XX

21.03.02		KT	vB	vB/Sb	
Date	S	TZ	Off. in ch.	contr. techn.	contr. Norm
Dept.: PA-007	vB		Nr. 36-7363B		
Up date:	XXXXXX/ 36-XXXX		Replaces: XXXXXX/ 36-XXXX		
MB-8U2	Scale: - - -		Sheet 2 of 2		

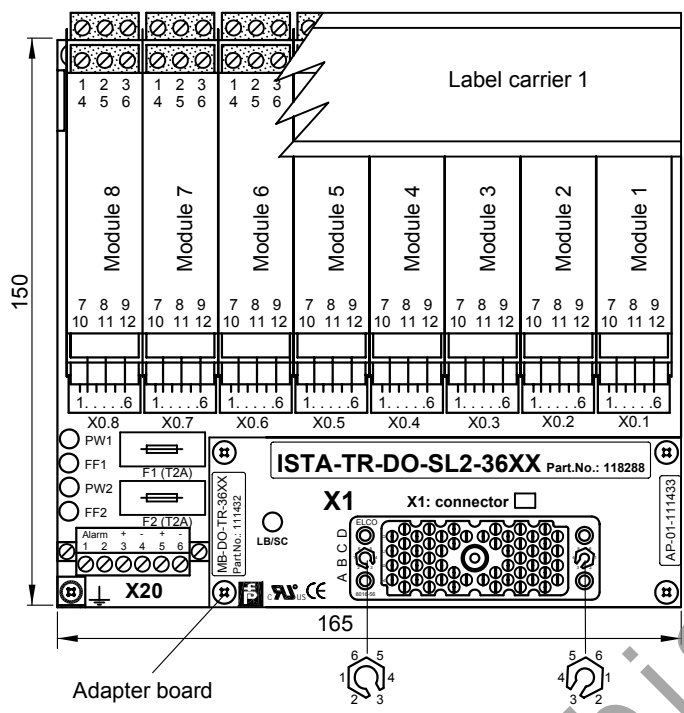

APPLICATION:

TRICONEX I/O card 3604E
16 points, non commoned

Motherboard 1: connected with connector #A
Module 1 ... 8, channels 1 ... 16

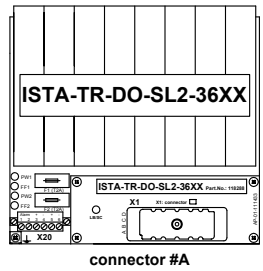

connector #A

APPLICATION:

TRICONEX I/O card 3664: will be required 2 x ISTA-TR-DO-SL2-36XX-118288
32 points, non commoned

Motherboard 2: connected with connector #B
Module 1 ... 8, channels 17 ... 32

Motherboard 1: connected with connector #A
Module 1 ... 8, channels 1 ... 16

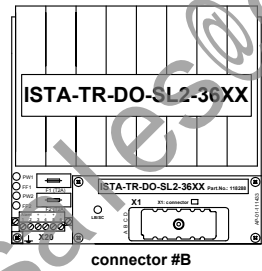

connector #B

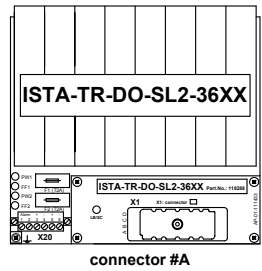

connector #A

Name	Note
X1	56 pin female system connector ELCO (small key: 3, large key: 3)
-----	-----
X0.1 16	6 pin male terminals for cable tree FSY....
X20.3 6	Power supply screw terminals
X20.1, X20.2	Alarm screw terminal
F1, F2	Fuse
PW1, PW2, FF1, FF2	LEDs for power and power failure
Power Rail	PR-03 (with 3 conductors)

Ordering information: ISTA-TR-DO-SL2-36XX-118288

Basic components:	Description
8 pieces:	KFD2-SL2-Ex2 (DO) KF-Module type (function)
1 piece:	MB-DO-TR-36XX-111432 Motherboard without modules
composed by:	
1 piece:	MB-8U2-Y97680 Motherboard without modules, adapter board, FSY cable tree and Label carrier
1 piece:	AP-01-111433 Adapter board
1 piece:	KFD0-LC1-8M-99143 Label carrier 1
8 pieces:	FSY-L456-98837 Cable tree connection KF-Module-Motherboard

copyright according to DIN34 unauthorized distribution and reproduction prohibited

	Motherboard unit Digital Output 16 channels - LB/SC monitoring ISTA-TR-DO-SL2-36XX	21.03.02	KT	vB	vB/Sb	
		Date	S TZ	Off. in ch.	contr. techn.	contr. Norm
		Dept.: PA-VP	Nr. 36-7358A			
		Up date: 04.05.07	Replaces: XXXXXX/ 36-XXXX		Sheet 1	
		MB-8U2	Scale: 1 : 2, 1 : 5		of 2	

copyright according to DIN34
unauthorized distribution and reproduction prohibited

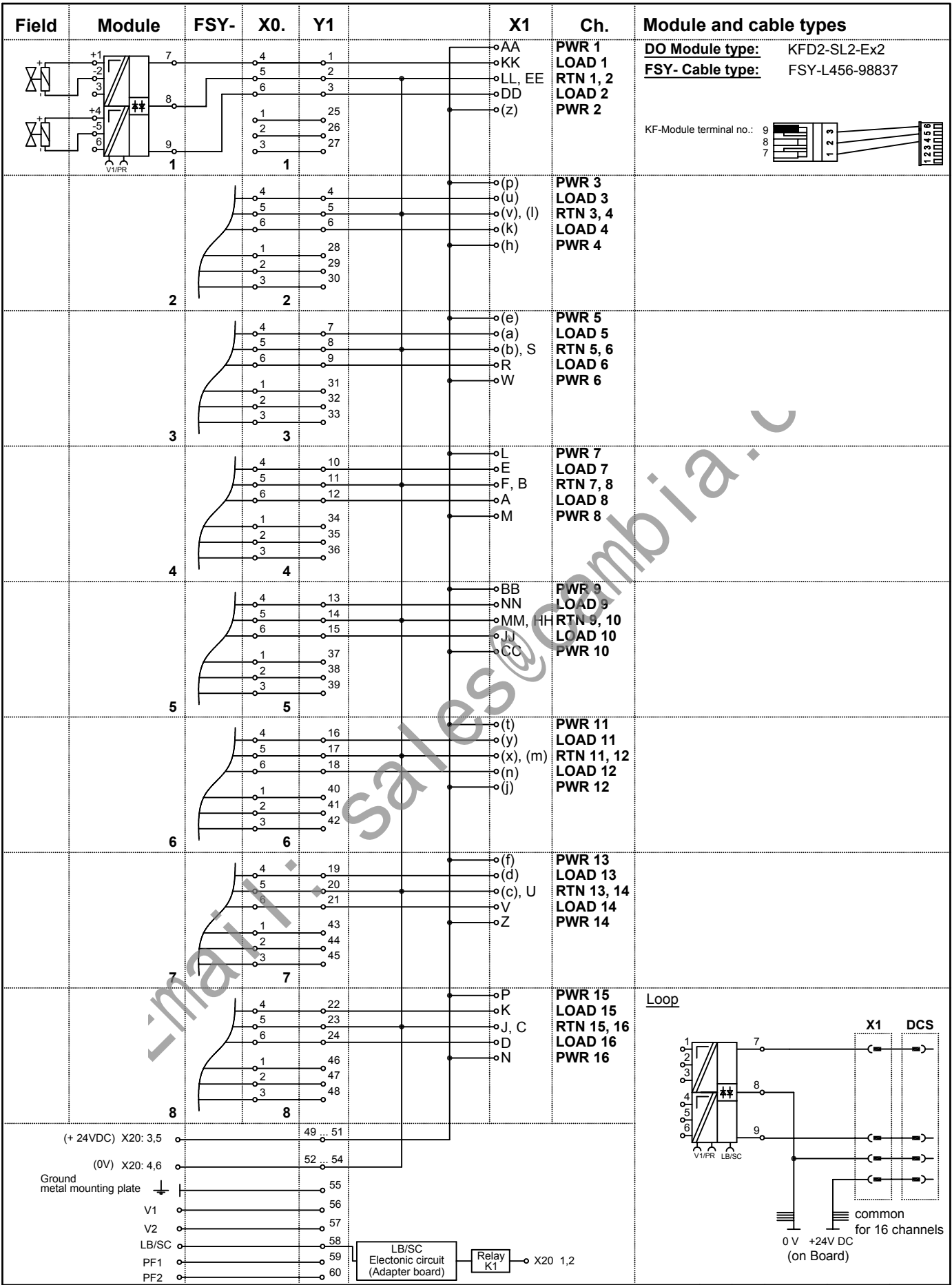

Note: Letters in brackets are small letters

PEPPERL+FUCHS
Mannheim-Schönau

Motherboard unit
Digital Output
16 channels - LB/SC monitoring
ISTA-TR-DO-SL2-36XX

21.03.02		KT	vB	vB/Sb	
Date	S	TZ	Off. in ch.	contr. techn.	contr. Norm
Dept.: PA-VP	vB		Nr. 36-7358A		
Up date: 04.05.07	Replaces: XXXXXX/ 36-XXXX		Sheet 2		
MB-8U2	Scale: - : -		of 2		

7. 3703E Application

(16 channels AI)

	Page
Simplified schematic 3703E	7- 1
Motherboard ISTA-TR-AI-STC-370X-118275	7- 3
Part No.:	118275
Function:	Analog Input + HART
Channels:	16
System cable:	(ELCO connector)
KF- Module:	KFD2-STC4-Ex1 (single channel)
Simplified schematic:	drawing no. 36-9288
Wiring Diagram:	drawing no. 36-7463
Motherboard ISTA-TR-AI-UT-370X-118276	7- 6
Part No.:	118276
Function:	Analog Input + HART
Channels:	16
System cable:	(ELCO connector)
KF- Module:	KFD2-UT-Ex1 (single channel)
Simplified schematic:	drawing no. 36-9288
Wiring Diagram:	drawing no. 36-7175

3703E ANALOG INPUT MODULE

**Simplified schematic of a typical 16-point analog input module
(1 of 16 points shown)**

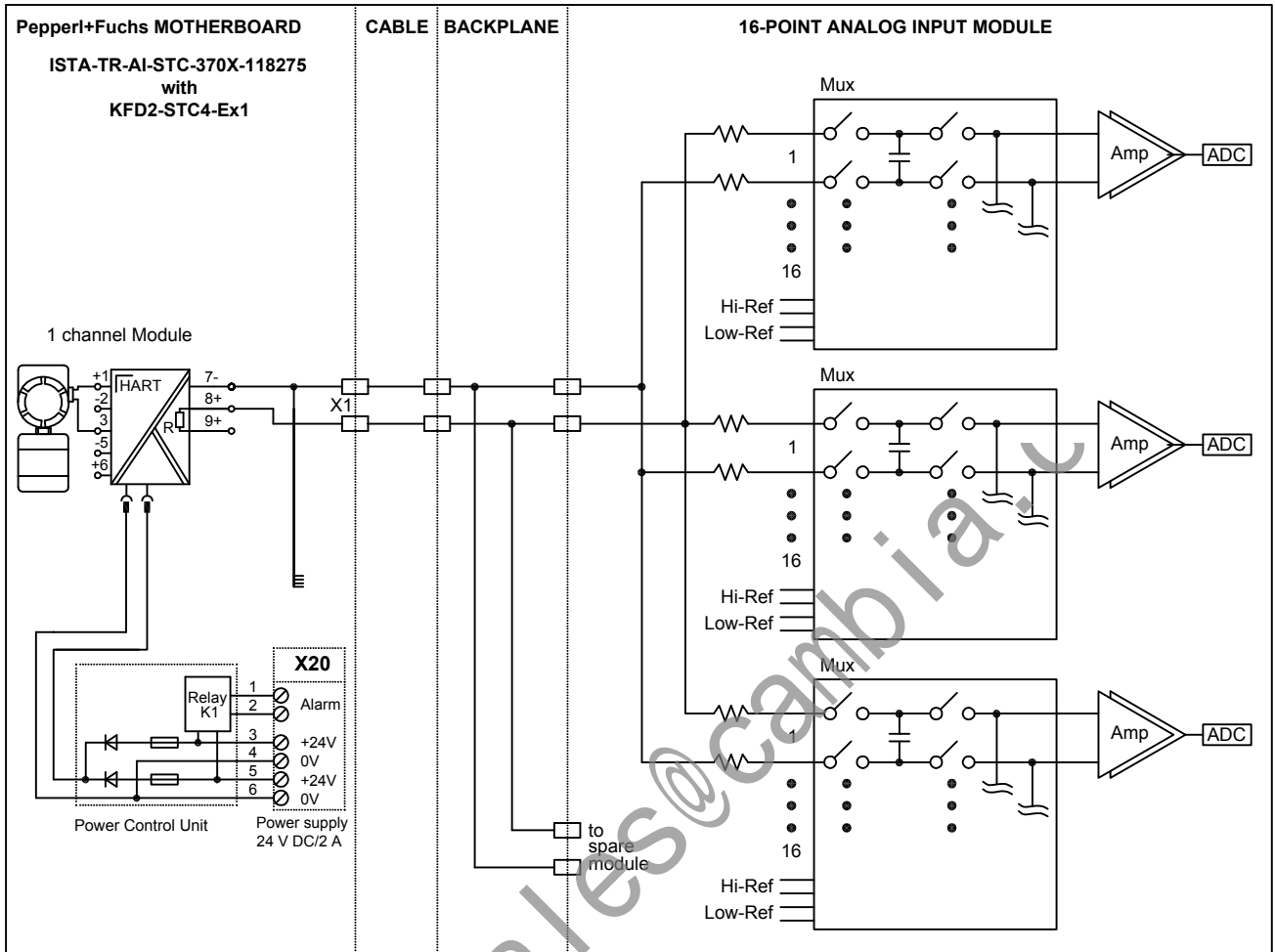

Pin assignment of connector #A (56 pin ELCO female)

Pin	AA	KK	LL	z	DD	EE	p	u	v	h	k	l	e	a
Signal	IN1+	*	IN1-	IN2+	*	IN2-	IN3+	*	IN3-	IN4+	*	IN4-	IN5+	*
Pin	b	W	R	S	L	E	F	M	A	B	BB	NN	MM	CC
Signal	IN5-	IN6+	*	IN6-	IN7+		IN7-	IN8+		IN8-	IN9+		IN9-	IN10+
Pin	JJ	HH	t	y	x	j	n	m	f	d	c	Z	V	U
Signal		IN10-	IN11+		IN11-	IN12+		IN12-	IN13+		IN13-	IN14+		IN14-
Pin	P	K	J	N	D	C	T	H	w	FF	r	s	X	Y
Signal	IN15+		IN15-	IN16+		IN16-	CGND	CGND	CGND	CGND	**	**	**	**

* Reserved for internal use. Do not connect for any purpose.

** not used

CGND is the chassis ground

02.03.99		AJ	AJ	--	
Date	S	TZ	Off. in ch.	contr. techn.	contr. Norm



D-TR-3703E

Dept.: PA-VP	Nr. 36-9288
vB/Bro	Replaces: XXXXX / 36-XXXX
Up date: 23.03.04	Sheet 1
Scale: - : -	of 2

3703E ANALOG INPUT MODULE

Simplified schematic of a typical 16-point analog input module
(1 of 16 points shown)

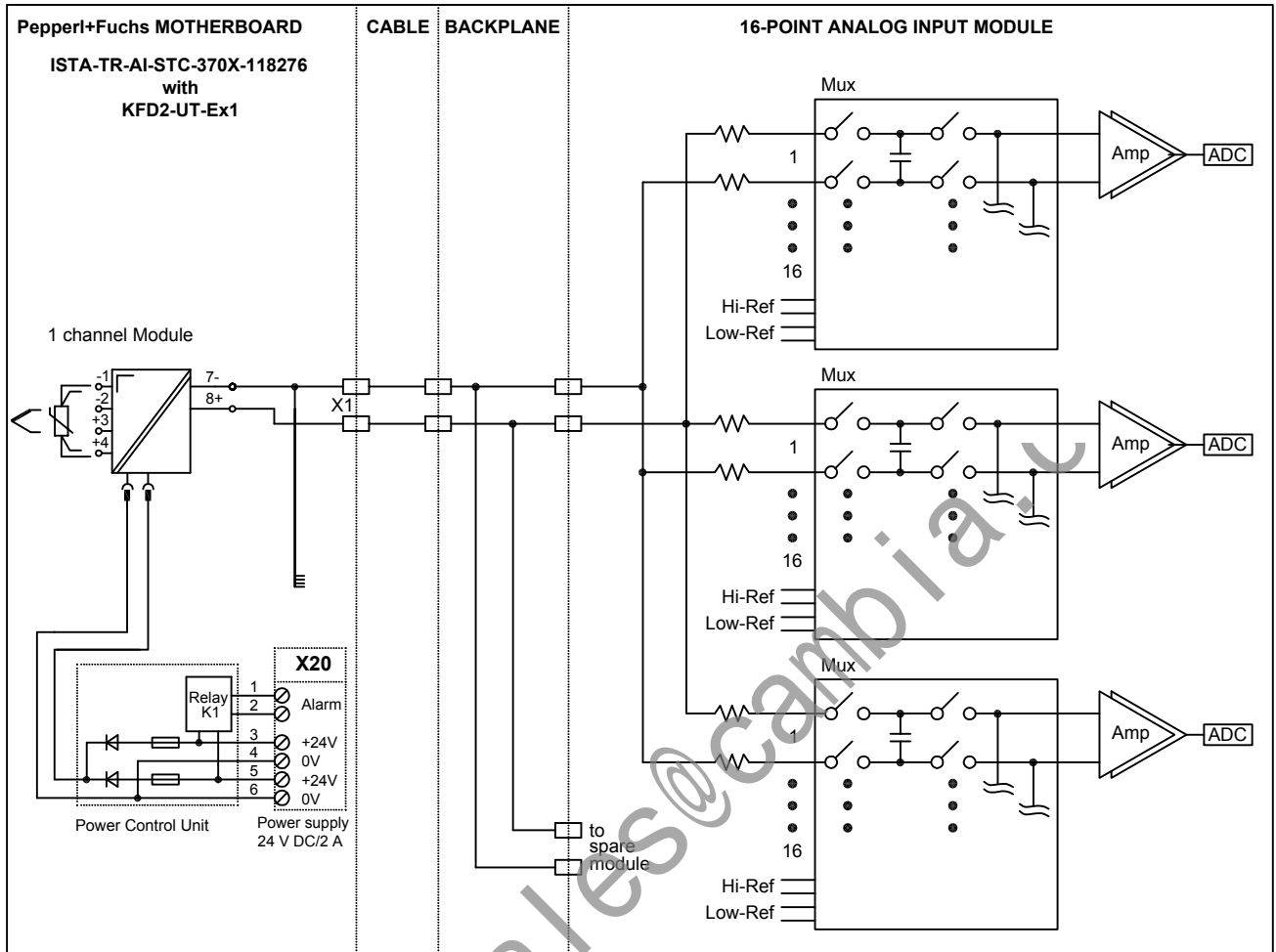

Pin assignment of connector #A (56 pin ELCO female)

Pin	AA	KK	LL	z	DD	EE	p	u	v	h	k	l	e	a
Signal	IN1+	*	IN1-	IN2+	*	IN2-	IN3+	*	IN3-	IN4+	*	IN4-	IN5+	*
Pin	b	W	R	S	L	E	F	M	A	B	BB	NN	MM	CC
Signal	IN5-	IN6+	*	IN6-	IN7+		IN7-	IN8+		IN8-	IN9+		IN9-	IN10+
Pin	JJ	HH	t	y	x	j	n	m	f	d	c	Z	V	U
Signal		IN10-	IN11+		IN11-	IN12+		IN12-	IN13+		IN13-	IN14+		IN14-
Pin	P	K	J	N	D	C	T	H	w	FF	r	s	X	Y
Signal	IN15+		IN15-	IN16+		IN16-	CGND	CGND	CGND	CGND	**	**	**	**

* Reserved for internal use. Do not connect for any purpose.

** not used

CGND is the chassis ground

12.05.03		KT	Sb	Sb	
Date	S	TZ	Off. in ch.	contr. techn.	contr. Norm
Dept.:	PA-VP		Nr. 36-9288		
Up date:	vB/Bro 23.03.04		Replaces: XXXXX / 36-XXXX		Sheet 2
Scale:			- : - of 2		



PEPPERL+FUCHS
Mannheim-Schönau

D-TR-3703E

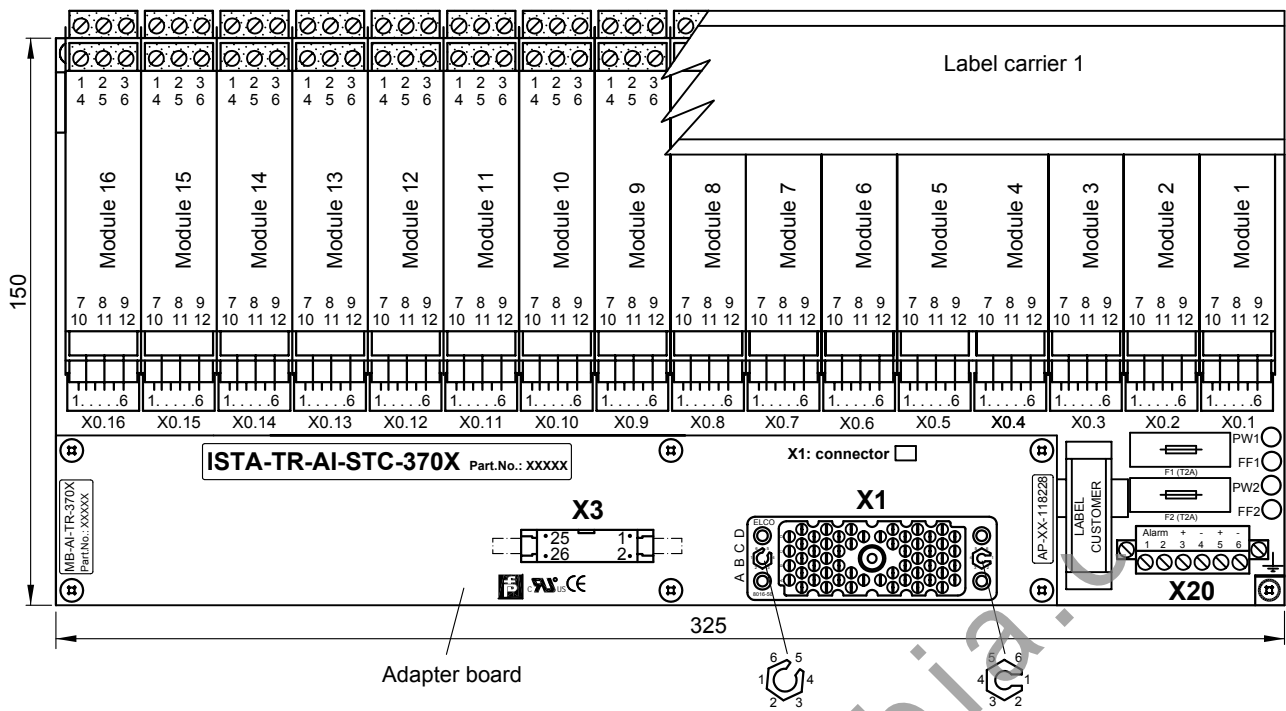

APPLICATION:
TRICONEX I/O card 3703E
 16 points, non commoned, diff., DC coupled

Module 1 ... 16, channels 1 ... 16

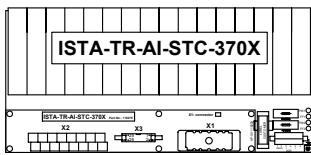

APPLICATION:
TRICONEX I/O card 3700 / 3700A / 3701 (2 x ISTA-TR-AI-STC-370X-XXXXX)
 16 + 16 points, non commoned, diff., DC coupled

Motherboard: connected with connector #B
 Module 1 ... 16, channels 1 ... 16

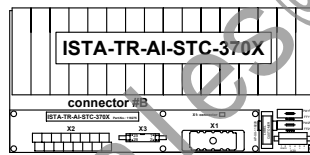

Motherboard: connected with connector #A
 Module 1 ... 16, channels 1 ... 16

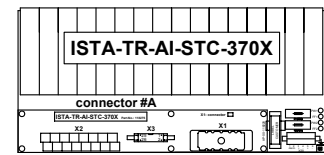

Name	Note
X1	56 pin female system connector ELCO (small key: 1, large key: 5)
X3	26 pin HART connector male
X0.1 ... 16	6 pin male terminals for cable tree FSY....
X20.3 ... 6	Power supply screw terminals
X20.1, X20.2	Alarm screw terminal
F1, F2	Fuse
PW1, PW2, FF1, FF2	LEDs for power and power failure

Ordering information:	ISTA-TR-AI-STC-370X-118275	ISTA-TR-AI-STC-370X-190081	Description
Basic components:			
16 pieces:	KFD2-STC4-Ex1 (AI)	KFD2-STC4-1 (AI)	KF-Module type (function)
1 piece:	MB-AI-TR-370X-118261	MB-AI-TR-370X-190082	Motherboard without modules
composed by:			
1 piece:	MB-16U5L-103681	MB-16U5L-103681	Basis Motherboard (*)
1 piece:	AP-11-118228	AP-12-118228	Adapter board
1 piece:	KFD0-LC1-16M-99144	KFD0-LC1-16M-99144	Label carrier 1
16 pieces:	FSY-L450-98833	FSY-L450-98833	FSY-Cable tree

(*) Basis Motherboard without modules, adapter board and FSY cable tree (connection between Motherboard and Modules)

Note:
 For application with module type KFD2-UT-EX1 see part nr. 118276 and 127703 drawing nr. 36-7175

21.03.02		KT	vB	Sb/vB	
Date	S	TZ	Off. in ch.	contr. techn.	contr. Norm
Dept.: PA-VP				Nr. 36-7463i	
Up date: 12.06.08				Replaces: 127672-127676 (36-7560)	Sheet 1
MB-16U5L				Scale: 1 : 2, 1 : 8	of 3

Field	Module	FSY-	X0.	Y1		X1	Ch.	Module and cable types
			4 5 6	1 2 3	R1	LL AA	IN1- IN1+	AI Module type: KFD2-STC4-Ex1 KFD2-STC4-1 FSY- Cable type: FSY-L450-98833 KF-Module terminal no.: 9 8 7
			4 5 6	4 5 6	R2	EE (z)	IN2- IN2+	
			4 5 6	7 8 9	R3	(v) (p)	IN3- IN3+	
			4 5 6	10 11 12	R4	(L) (h)	IN4- IN4+	
			4 5 6	13 14 15	R5	(b) (e)	IN5- IN5+	
			4 5 6	16 17 18	R6	S W	IN6- IN6+	
			4 5 6	19 20 21	R7	F L	IN7- IN7+	
			4 5 6	22 23 24	R8	B M	IN8- IN8+	
					Y1: 25			

 PEPPERL+FUCHS Mannheim-Schönau	Motherboard unit Analog Input - HART 16 channels ISTA-TR-AI-STC-370X				21.03.02 Date	S TZ	KT Off. in ch.	vB Replaces: 127672-127676 (36-7560)	Sb/vB contr. techn.	contr. Norm
	Dept.: PA-VP vB Up date: 12.06.08		Nr. 36-7463i			Sheet 2				
	MB-16U5L		Scale: - - - of 3							

Field	Module	FSY-	X0.	Y1		X1	Ch.
	9		9	25 26 27 85 86 87	R9	MM BB 16	IN9- IN9+
	10		10	28 29 30 88 89 90	R10	HH CC 17	IN10- IN10+
	11		11	31 32 33 91 92 93	R11	(x) (t) 18	IN11- IN11+
	12		12	34 35 36 94 95 96	R12	(m) (j) 19	IN12- IN12+
	13		13	37 38 39 97 98 99	R13	(c) (f) 20	IN13- IN13+
	14		14	40 41 42 100 101 102	R14	U Z 21	IN14- IN14+
	15		15	43 44 45 103 104 105	R15	J P 22	IN15- IN15+
	16		16	46 47 48 106 107 108	R16	C N 23	IN16- IN16+
				49 ... 51 52 ... 54 55 56 57 58 59 60		1 ... 5 14, 15 24 ... 26	
				(+ 24VDC) X20: 3,5 (0V) X20: 4,6 Ground metal mounting plate V1 V2 LB/SC PF1 PF2			

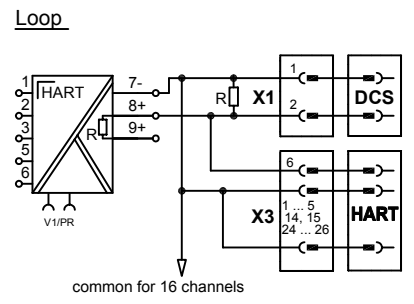

R= 250 ohm resistors 0.01%
 Note: Letters in brackets are small letters

22.03.02		KT	vB	Sb/vB	
Date	S	TZ	Off. in ch.	contr. techn.	contr. Norm
Dept.: PA-VP	Nr. 36-7463i				
Up date: 12.06.08	Replaces: 127672-127676 (36-7560)		Sheet 3		
MB-16U5L	Scale: - - -		of 3		

PEPPERL+FUCHS
 Mannheim-Schönau

Motherboard unit
 Analog Input - HART
 16 channels
ISTA-TR-AI-STC-370X

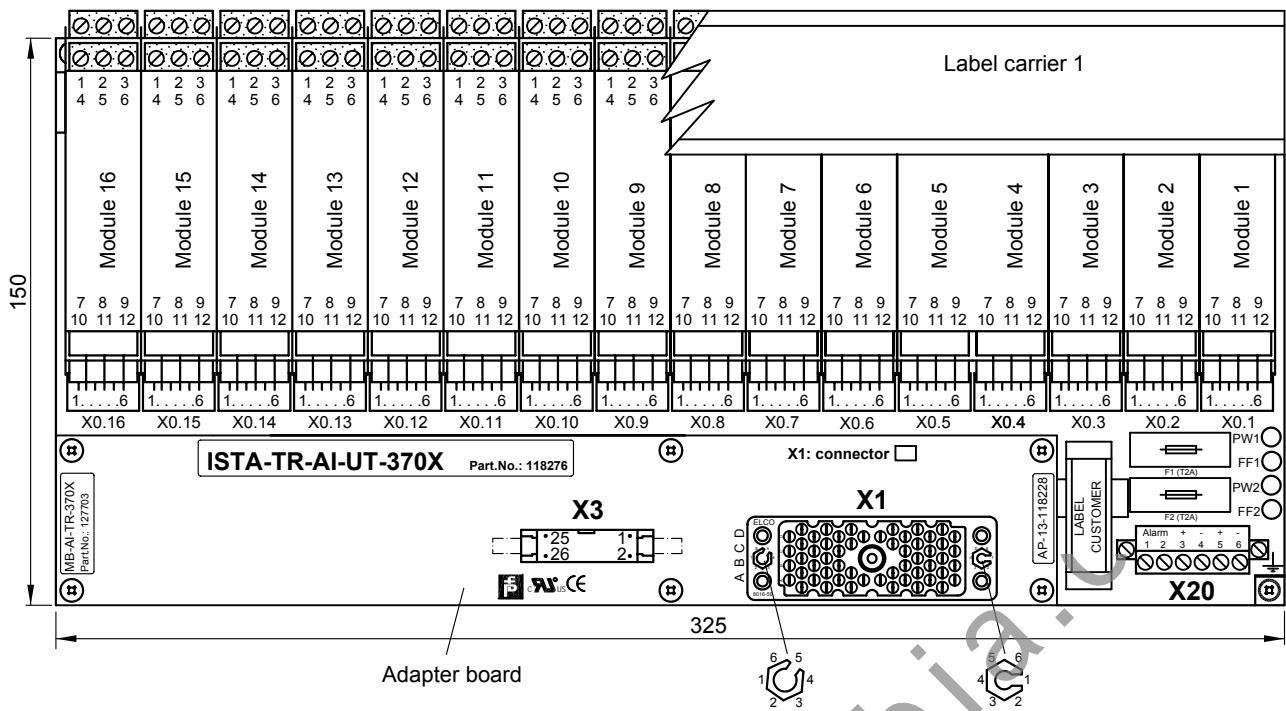

APPLICATION:

TRICONEX I/O card 3703E

16 points, non commoned, diff., DC coupled

Module 1 ... 16, channels 1 ... 16

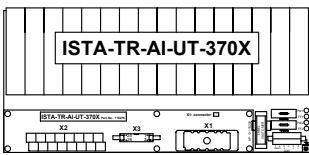

APPLICATION:

TRICONEX I/O card 3700 / 3700A / 3701 (2 x ISTA-TR-AI-UT-370X-118276)

16 + 16 points, non commoned, diff., DC coupled

Motherboard: connected with connector #B
Module 1 ... 16, channels 1 ... 16

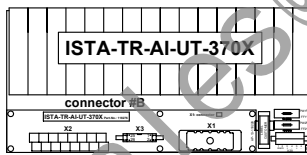

Motherboard: connected with connector #A
Module 1 ... 16, channels 1 ... 16

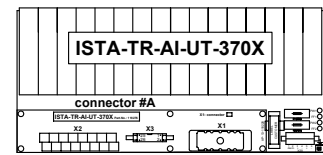

Name	Note
X1	56 pin female system connector ELCO (small key: 1, large key: 5)
X3	26 pin HART connector
X0.1 16	6 pin male terminals for cable tree FSY....
X20.3 6	Power supply screw terminals
X20.1, X20.2	Alarm screw terminal
F1, F2	Fuse
PW1, PW2, FF1, FF2	LEDs for power and power failure

Ordering information: ISTA-TR-AI-UT-370X-118276

Basic components:	Description
16 pieces: KFD2-UT-Ex1 *) (AI)	KF-Module type (function)
1 piece: MB-AI-TR-370X-127703	Motherboard without modules
composed by:	
1 piece: MB-16U5L-103681	Motherboard without modules, adapter board, FSY cable tree and Label carrier
1 piece: AP-13-118228	Adapter board
1 piece: KFD0-LC1-16M-99144	Label carrier 1
16 pieces: FSY-L450-98833	Cable tree connection KF-Module-Motherboard

*) No HART communication

Note:

For application with module type KFD2-STC4-EX1 see part nr. 118275 and 118261 drawing nr. 36-7463

22.03.02	KT	vB	Sb/vB	
Date	S TZ	Off. in ch.	contr. techn.	contr. Norm
Dept.: PA-VP	Nr. 36-7175e			
Up date: 17.06.08	vB	Replaces: 116534/ 36-7416	Sheet 1	
MB-16U5L	Scale: 1 : 2, 1 : 8	of 3		



PEPPERL+FUCHS
Mannheim-Schönau

Motherboard unit
Analog Input - HART
16 channels
ISTA-TR-AI-UT-370X

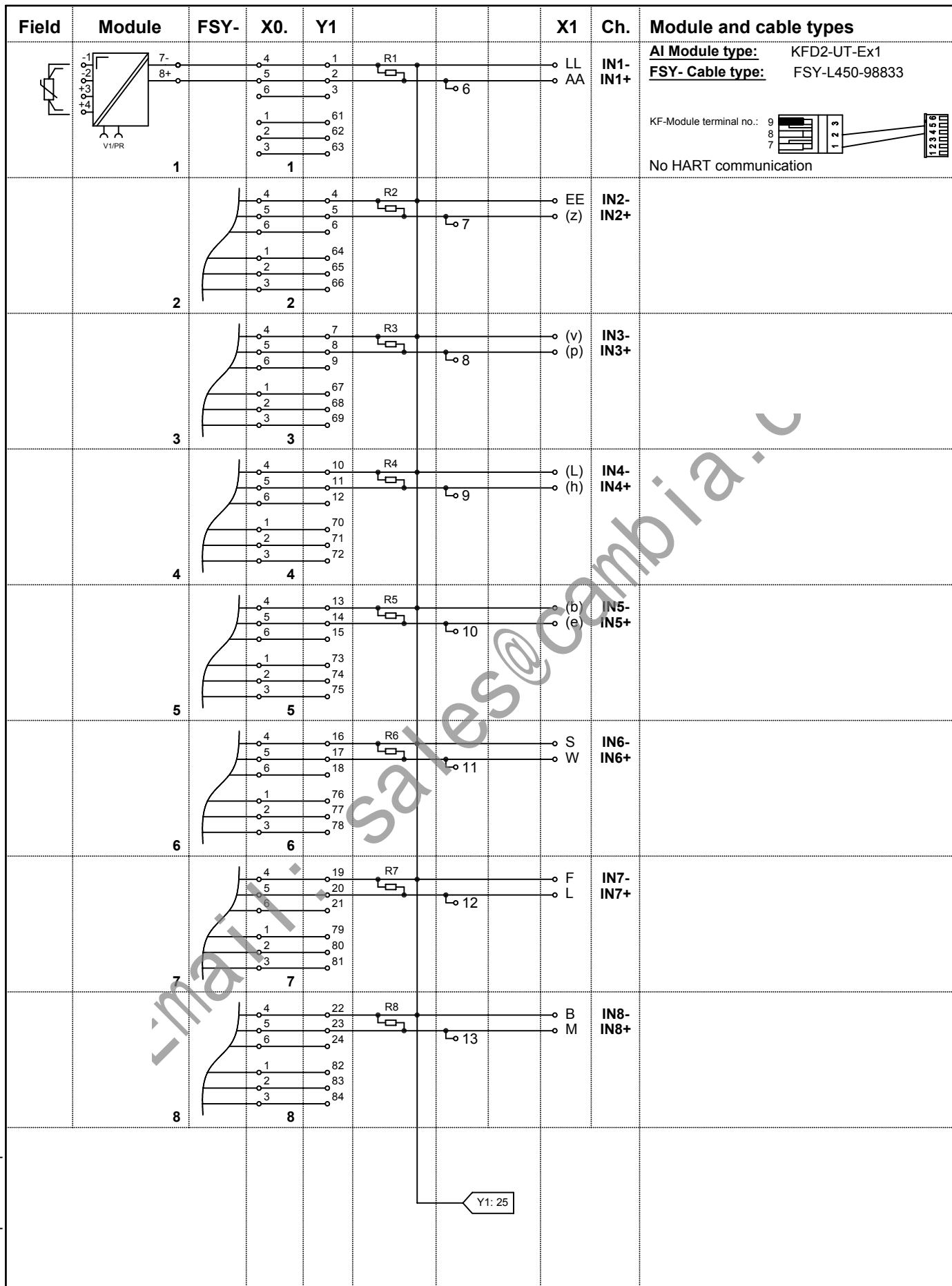

22.03.02		KT	vB	Sb/vB	
Date	S	TZ	Off. in ch.	contr. techn.	contr. Norm
Dept.: PA-VP	Nr. 36-7175e				
Up date: 17.06.08	Replaces: xxxx / 36-xxxx		Sheet 2		
MB-16U5L	Scale: - -		of 3		

PEPPERL+FUCHS
 Mannheim-Schönau

Motherboard unit
 Analog Input - HART
 16 channels
ISTA-TR-AI-UT-370X

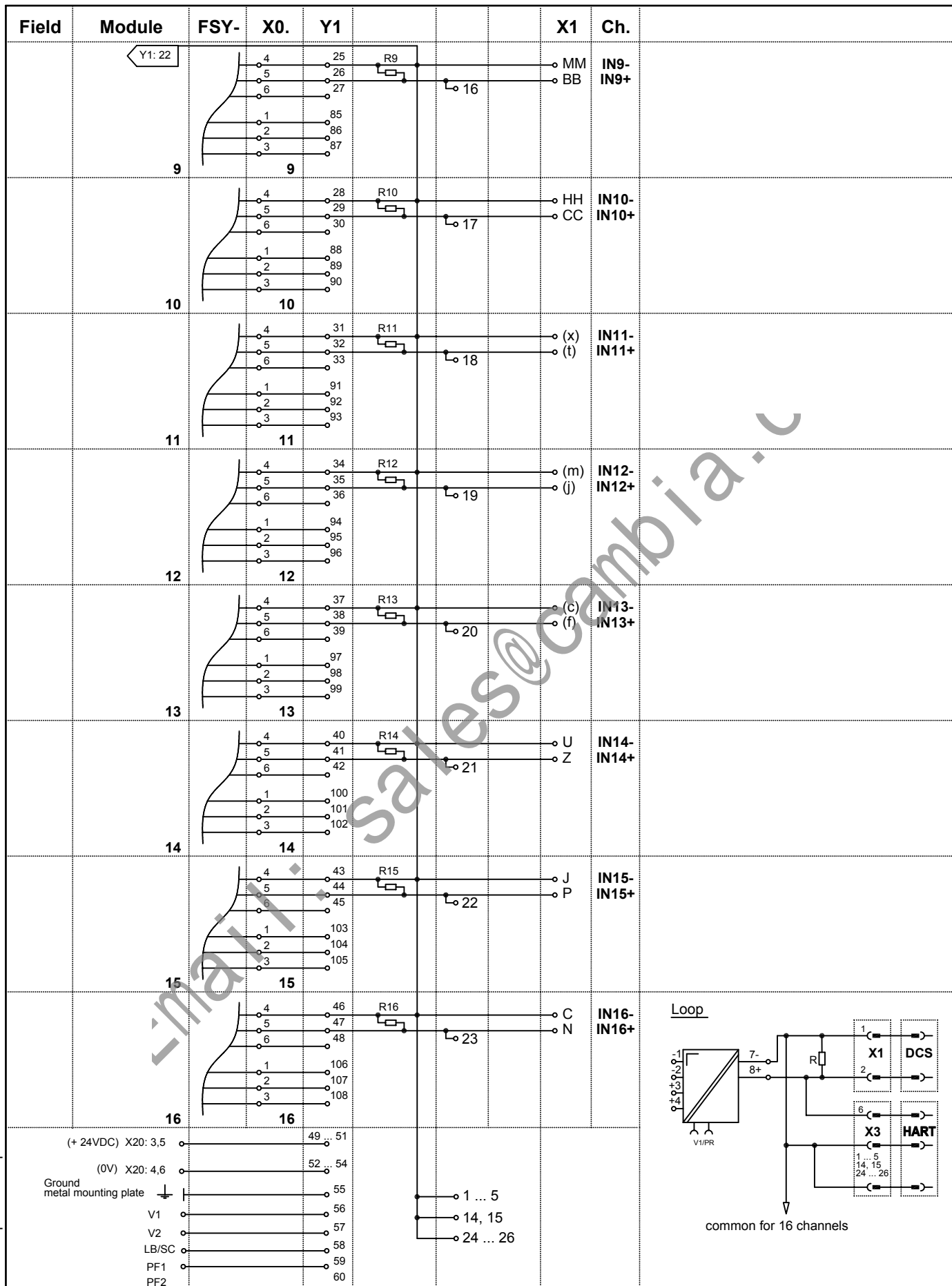

R= 250 ohm resistors 0.01%

Note: Letters in brackets are small letters

23.03.02		KT	vB	Sb/vB	
Date	S	TZ	Off. in ch.	contr. techn.	contr. Norm
Dept.: PA-VP	Nr. 36-7175e				
Up date: 17.06.08	Replaces: xxxxx / 36-xxxx		Sheet 3		
MB-16U5L	Scale: - : -		of 3		

PEPPERL+FUCHS
 Mannheim-Schönau

Motherboard unit
 Analog Input - HART
 16 channels
ISTA-TR-AI-UT-370X

8. 37000 / 3700A / 3701 / 3721 Application

(16 + 16 channels AI)

	Page
Simplified schematic 3700 / 3700A / 3701 / 3721	8- 1
2 x Motherboard ISTA-TR-AI-STC-370X-118275	8- 3
Part No.:	118275
Function:	Analog Input + HART
Channels:	16
System cable:	(ELCO connector)
KF- Module:	KFD2-STC4-Ex1 (single channel)
Simplified schematic:	drawing no. 36-9289
Wiring Diagram:	drawing no. 36-7463
2 x Motherboard ISTA-TR-AI-UT-370X-118276	8- 6
Part No.:	118276
Function:	Analog Input + HART
Channels:	16
System cable:	(ELCO connector)
KF- Module:	KFD2-UT-Ex1 (single channel)
Simplified schematic:	drawing no. 36-9289
Wiring Diagram:	drawing no. 36-7175

3700 / 3700A / 3701 ANALOG INPUT MODULE

**Simplified schematic of a typical analog input module
(1 of 32 points shown)**

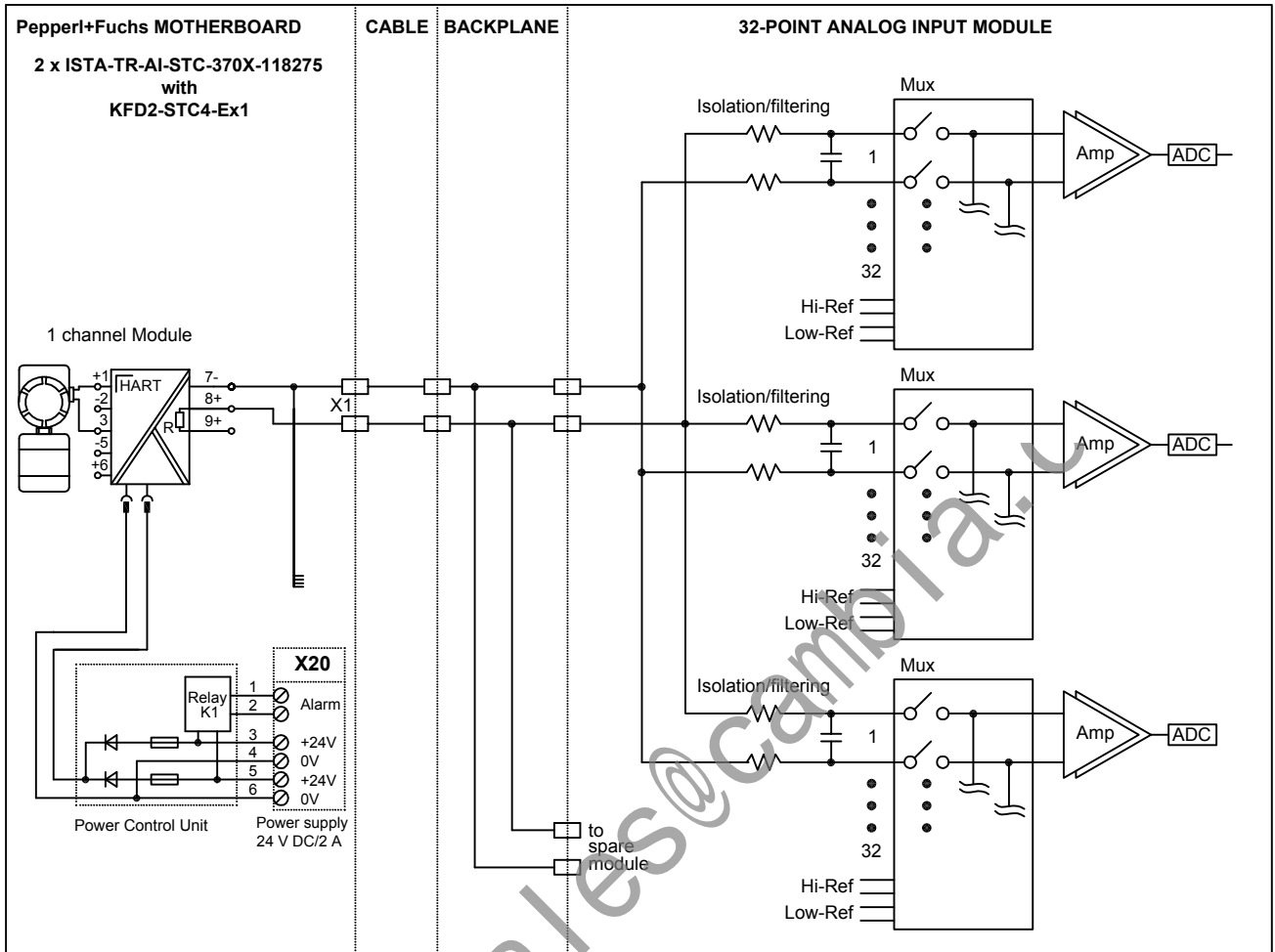

Pin assignment of connector #A (56 pin ELCO female)

Pin	AA	KK	LL	z	DD	EE	p	u	v	h	k	l	e	a
Signal	IN1+	*	IN1-	IN2+	*	IN2-	IN3+	*	IN3-	IN4+	*	IN4-	IN5+	*
Pin	b	W	R	S	L	E	F	M	A	B	BB	NN	MM	CC
Signal	IN5-	IN6+	*	IN6-	IN7+		IN7-	IN8+		IN8-	IN9+		IN9-	IN10+
Pin	JJ	HH	t	y	x	j	n	m	f	d	c	Z	V	U
Signal		IN10-	IN11+		IN11-	IN12+		IN12-	IN13+		IN13-	IN14+		IN14-
Pin	P	K	J	N	D	C	T	H	w	FF	r	s	X	Y
Signal	IN15+		IN15-	IN16+		IN16-	CGND	CGND	CGND	CGND	**	**	**	**

Pin assignment of connector #B (56 pin ELCO female)

Pin	AA	KK	LL	z	DD	EE	p	u	v	h	k	l	e	a
Signal	IN17+		IN17-	IN18+		IN18-	IN19+		IN19-	IN20+		IN20-	IN21+	
Pin	b	W	R	S	L	E	F	M	A	B	BB	NN	MM	CC
Signal	IN21-	IN22+		IN22-	IN23+		IN23-	IN24+		IN24-	IN25+		IN25-	IN26+
Pin	JJ	HH	t	y	x	j	n	m	f	d	c	Z	V	U
Signal		IN26-	IN27+		IN27-	IN28+		IN28-	IN29+		IN29-	IN30+		IN30-
Pin	P	K	J	N	D	C	T	H	w	FF	r	s	X	Y
Signal	IN31+		IN31-	IN32+		IN32-	CGND	CGND	CGND	CGND	**	**	**	**

* Reserved for internal use. Do not connect for any purpose.
** not used
CGND is the chassis ground

02.03.99	AJ	AJ	--	
Date	S	TZ	Off. in ch.	contr. techn.
			contr. Norm	



D-TR-3700 / 3700A / 3701

Dept.: PA-VP	Nr. 36-9289
B: Sb/KT	Replaces: XXXXX / 36-XXXX
Up date: 12.05.03	Sheet 1
Scale: - : -	of 2

copyright according to DIN34 unauthorized distribution and reproduction prohibited

3700 / 3700A / 3701 ANALOG INPUT MODULE

**Simplified schematic of a typical analog input module
(1 of 32 points shown)**

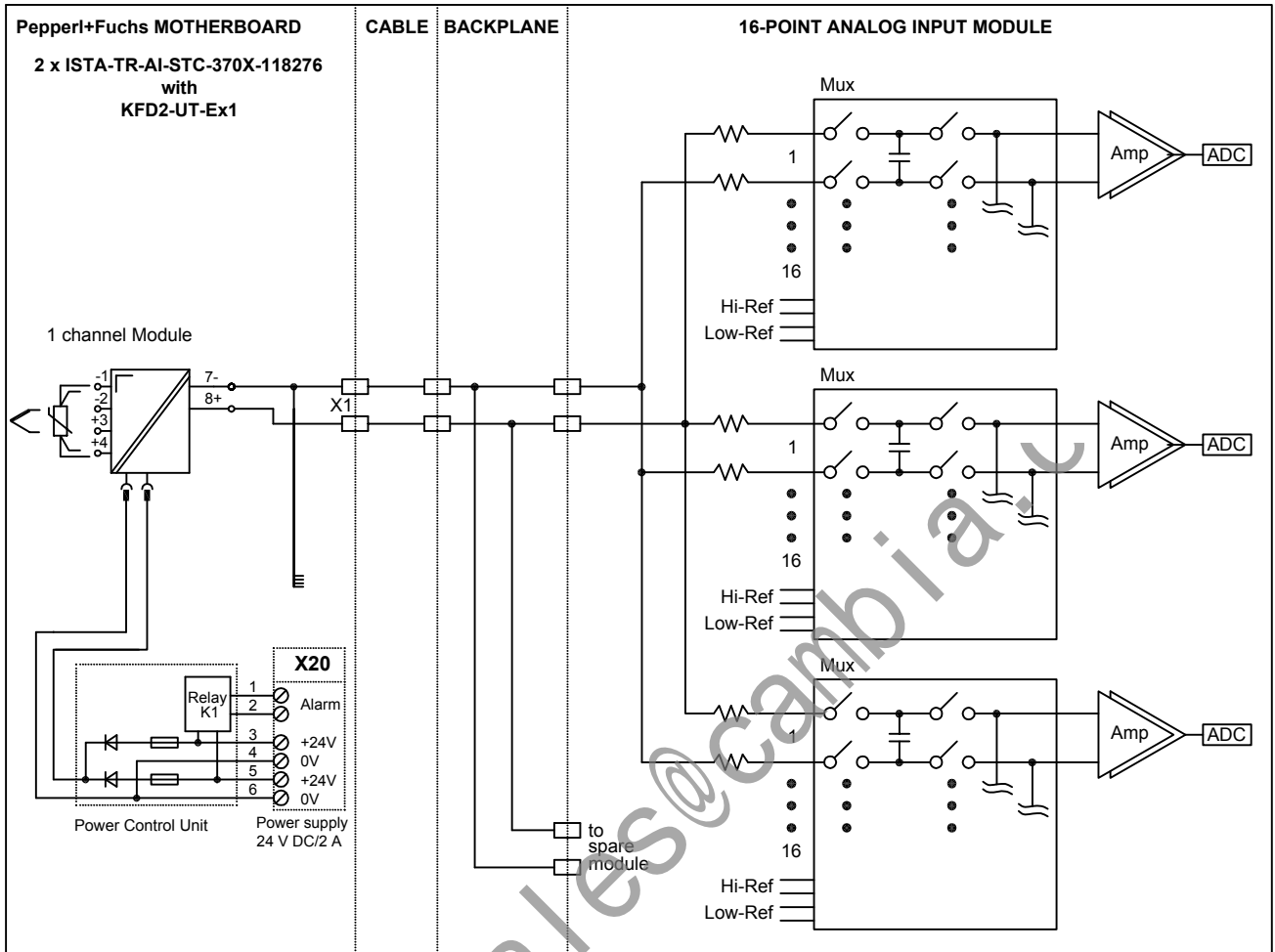

Pin assignment of connector #A (56 pin ELCO female)

Pin	AA	KK	LL	z	DD	EE	p	u	v	h	k	l	e	a
Signal	IN1+	*	IN1-	IN2+	*	IN2-	IN3+	*	IN3-	IN4+	*	IN4-	IN5+	*
Pin	b	W	R	S	L	E	F	M	A	B	BB	NN	MM	CC
Signal	IN5-	IN6+	*	IN6-	IN7+		IN7-	IN8+		IN8-	IN9+		IN9-	IN10+
Pin	JJ	HH	t	y	x	j	n	m	f	d	c	Z	V	U
Signal		IN10-	IN11+		IN11-	IN12+		IN12-	IN13+		IN13-	IN14+		IN14-
Pin	P	K	J	N	D	C	T	H	w	FF	r	s	X	Y
Signal	IN15+		IN15-	IN16+		IN16-	CGND	CGND	CGND	CGND	**	**	**	**

Pin assignment of connector #B (56 pin ELCO female)

Pin	AA	KK	LL	z	DD	EE	p	u	v	h	k	l	e	a
Signal	IN17+		IN17-	IN18+		IN18-	IN19+		IN19-	IN20+		IN20-	IN21+	
Pin	b	W	R	S	L	E	F	M	A	B	BB	NN	MM	CC
Signal	IN21-	IN22+		IN22-	IN23+		IN23-	IN24+		IN24-	IN25+		IN25-	IN26+
Pin	JJ	HH	t	y	x	j	n	m	f	d	c	Z	V	U
Signal		IN26-	IN27+		IN27-	IN28+		IN28-	IN29+		IN29-	IN30+		IN30-
Pin	P	K	J	N	D	C	T	H	w	FF	r	s	X	Y
Signal	IN31+		IN31-	IN32+		IN32-	CGND	CGND	CGND	CGND	**	**	**	**

* Reserved for internal use. Do not connect for any purpose.
** not used
CGND is the chassis ground

12.05.03	KT	Sb	Sb	
Date	S	TZ	Off. in ch.	contr. techn.
			contr. Norm	



3700 / 3700A / 3701

Dept.: PA-VP	Nr. 36-9289
vB/Bro	Replaces: XXXXX / 36-XXXX
Up date: 23.03.04	Sheet 2
Scale: - : -	of 2

copyright according to DIN34
unauthorized distribution and reproduction prohibited

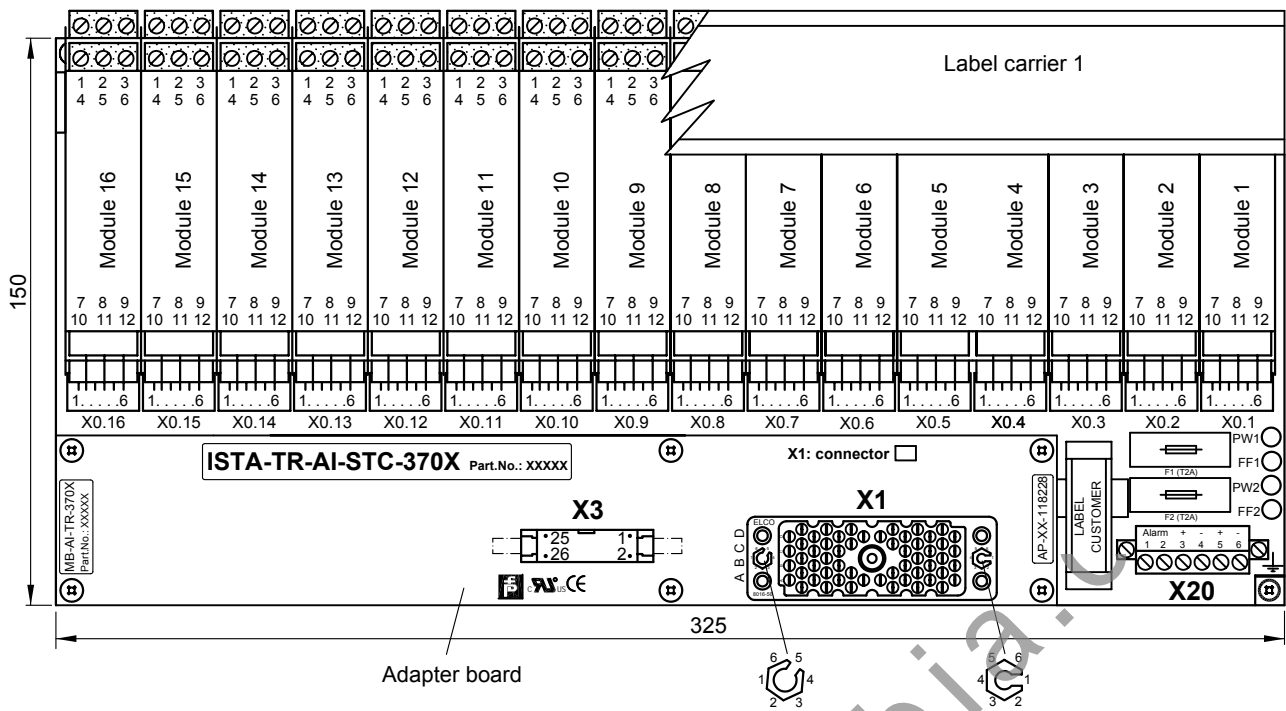

APPLICATION:
TRICONEX I/O card 3703E
 16 points, non commoned, diff., DC coupled

Module 1 ... 16, channels 1 ... 16

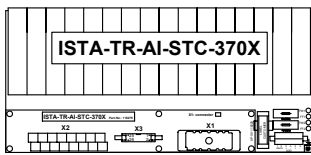

APPLICATION:
TRICONEX I/O card 3700 / 3700A / 3701 (2 x ISTA-TR-AI-STC-370X-XXXXX)
 16 + 16 points, non commoned, diff., DC coupled

Motherboard: connected with connector #B
 Module 1 ... 16, channels 1 ... 16

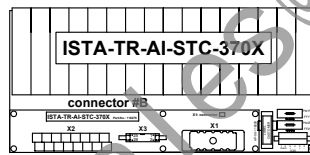

Motherboard: connected with connector #A
 Module 1 ... 16, channels 1 ... 16

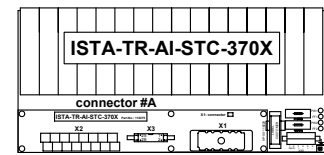

Name	Note
X1	56 pin female system connector ELCO (small key: 1, large key: 5)
X3	26 pin HART connector male
X0.1 ... 16	6 pin male terminals for cable tree FSY....
X20.3 ... 6	Power supply screw terminals
X20.1, X20.2	Alarm screw terminal
F1, F2	Fuse
PW1, PW2, FF1, FF2	LEDs for power and power failure

Ordering information:	ISTA-TR-AI-STC-370X-118275	ISTA-TR-AI-STC-370X-190081	Description
Basic components:			
16 pieces:	KFD2-STC4-Ex1 (AI)	KFD2-STC4-1 (AI)	KF-Module type (function)
1 piece:	MB-AI-TR-370X-118261	MB-AI-TR-370X-190082	Motherboard without modules
composed by:			
1 piece:	MB-16U5L-103681	MB-16U5L-103681	Basis Motherboard (*)
1 piece:	AP-11-118228	AP-12-118228	Adapter board
1 piece:	KFD0-LC1-16M-99144	KFD0-LC1-16M-99144	Label carrier 1
16 pieces:	FSY-L450-98833	FSY-L450-98833	FSY-Cable tree

(*) Basis Motherboard without modules, adapter board and FSY cable tree (connection between Motherboard and Modules)

Note:
 For application with module type KFD2-UT-EX1 see part nr. 118276 and 127703 drawing nr. 36-7175

21.03.02		KT	vB	Sb/vB	
Date	S	TZ	Off. in ch.	contr. techn.	contr. Norm
Dept.: PA-VP	vB		Nr. 36-7463i		
Up date: 12.06.08	Replaces: 127672-127676 (36-7560)		Sheet 1		
MB-16U5L	Scale: 1 : 2, 1 : 8		of 3		



PEPPERL+FUCHS
 Mannheim-Schönau

Motherboard unit
 Analog Input - HART
 16 channels
ISTA-TR-AI-STC-370X

Field	Module	FSY-	X0.	Y1		X1	Ch.
	9		4 5 6 1 2 3	25 26 27 85 86 87	R9 	MM BB 16	IN9- IN9+ Y1: 22
	10		4 5 6 1 2 3	28 29 30 88 89 90	R10 	HH CC 17	IN10- IN10+
	11		4 5 6 1 2 3	31 32 33 91 92 93	R11 	(x) (t) 18	IN11- IN11+
	12		4 5 6 1 2 3	34 35 36 94 95 96	R12 	(m) (j) 19	IN12- IN12+
	13		4 5 6 1 2 3	37 38 39 97 98 99	R13 	(c) (f) 20	IN13- IN13+
	14		4 5 6 1 2 3	40 41 42 100 101 102	R14 	U Z 21	IN14- IN14+
	15		4 5 6 1 2 3	43 44 45 103 104 105	R15 	J P 22	IN15- IN15+
	16		4 5 6 1 2 3	46 47 48 106 107 108	R16 	C N 23	IN16- IN16+
				49 ... 51 52 ... 54 55 56 57 58 59 60		1 ... 5 14, 15 24 ... 26	
			(+ 24VDC) X20: 3,5 (0V) X20: 4,6 Ground metal mounting plate V1 V2 LB/SC PF1 PF2				

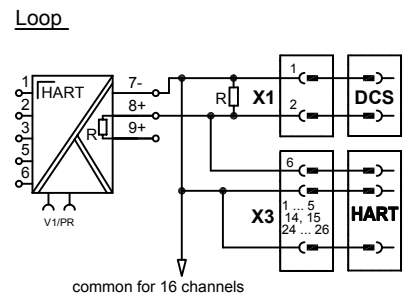

R= 250 ohm resistors 0.01%
 Note: Letters in brackets are small letters

22.03.02		KT	vB	Sb/vB	
Date	S	TZ	Off. in ch.	contr. techn.	contr. Norm
Dept.: PA-VP	vB		Nr. 36-7463i		
Up date: 12.06.08	Replaces: 127672-127676 (36-7560)		Sheet 3		
MB-16U5L	Scale: - - -		of 3		

PEPPERL+FUCHS
 Mannheim-Schönau

Motherboard unit
 Analog Input - HART
 16 channels
ISTA-TR-AI-STC-370X

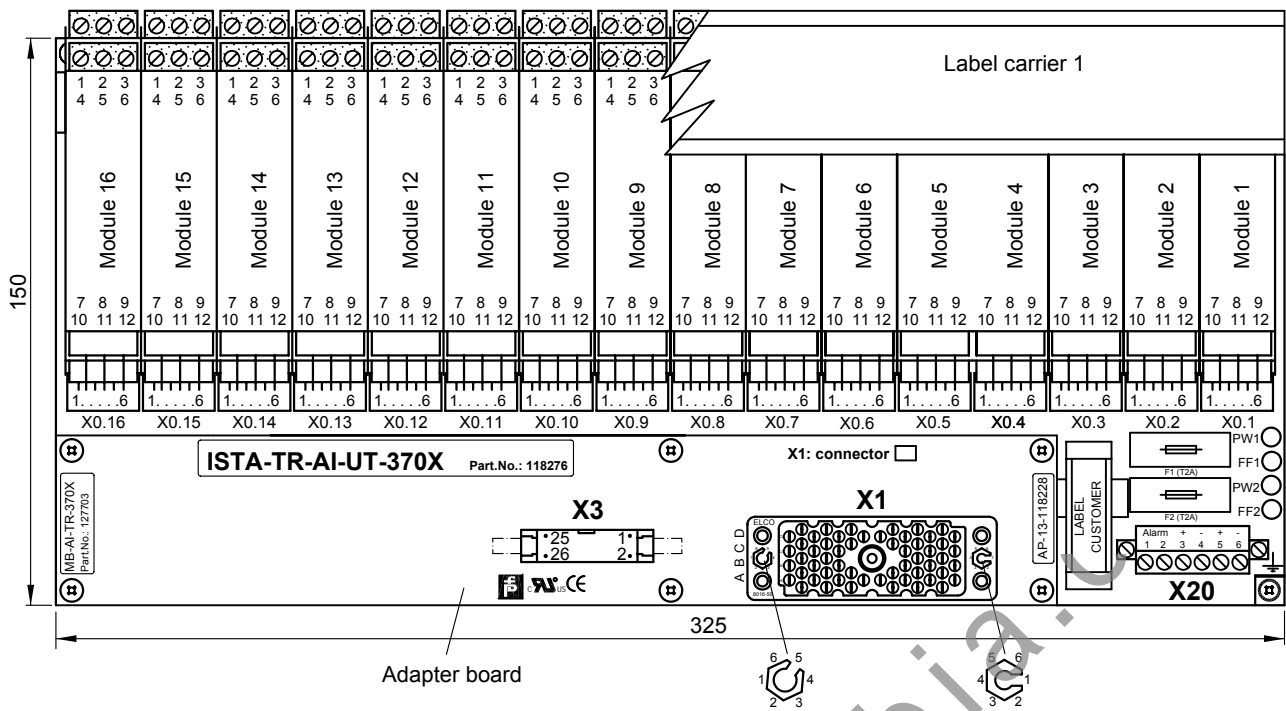

APPLICATION:

TRICONEX I/O card 3703E
16 points, non commoned, diff., DC coupled

Module 1 ... 16, channels 1 ... 16

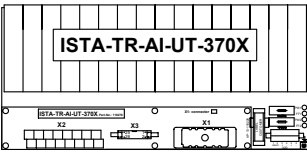

APPLICATION:

TRICONEX I/O card 3700 / 3700A / 3701 (2 x ISTA-TR-AI-UT-370X-118276)
16 + 16 points, non commoned, diff., DC coupled

Motherboard: connected with connector #B
Module 1 ... 16, channels 1 ... 16

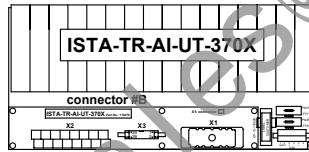

Motherboard: connected with connector #A
Module 1 ... 16, channels 1 ... 16

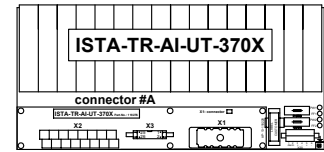

Name	Note
X1	56 pin female system connector ELCO (small key: 1, large key: 5)
X3	26 pin HART connector
X0.1 16	6 pin male terminals for cable tree FSY....
X20.3 6	Power supply screw terminals
X20.1, X20.2	Alarm screw terminal
F1, F2	Fuse
PW1, PW2, FF1, FF2	LEDs for power and power failure

Ordering information: ISTA-TR-AI-UT-370X-118276

Basic components:	Description
16 pieces: KFD2-UT-Ex1 *) (AI)	KF-Module type (function)
1 piece: MB-AI-TR-370X-127703	Motherboard without modules
composed by:	
1 piece: MB-16U5L-103681	Motherboard without modules, adapter board, FSY cable tree and Label carrier
1 piece: AP-13-118228	Adapter board
1 piece: KFD0-LC1-16M-99144	Label carrier 1
16 pieces: FSY-L450-98833	Cable tree connection KF-Module-Motherboard

*) No HART communication

Note:

For application with module type KFD2-STC4-EX1 see part nr. 118275 and 118261 drawing nr. 36-7463

22.03.02	KT	vB	Sb/vB	
Date	S TZ	Off. in ch.	contr. techn.	contr. Norm
Dept.: PA-VP	Nr. 36-7175e			
Up date: 17.06.08	vB	Replaces: 116534/ 36-7416	Sheet 1	
MB-16U5L	Scale: 1 : 2, 1 : 8	of 3		



PEPPERL+FUCHS
Mannheim-Schönau

Motherboard unit
Analog Input - HART
16 channels
ISTA-TR-AI-UT-370X

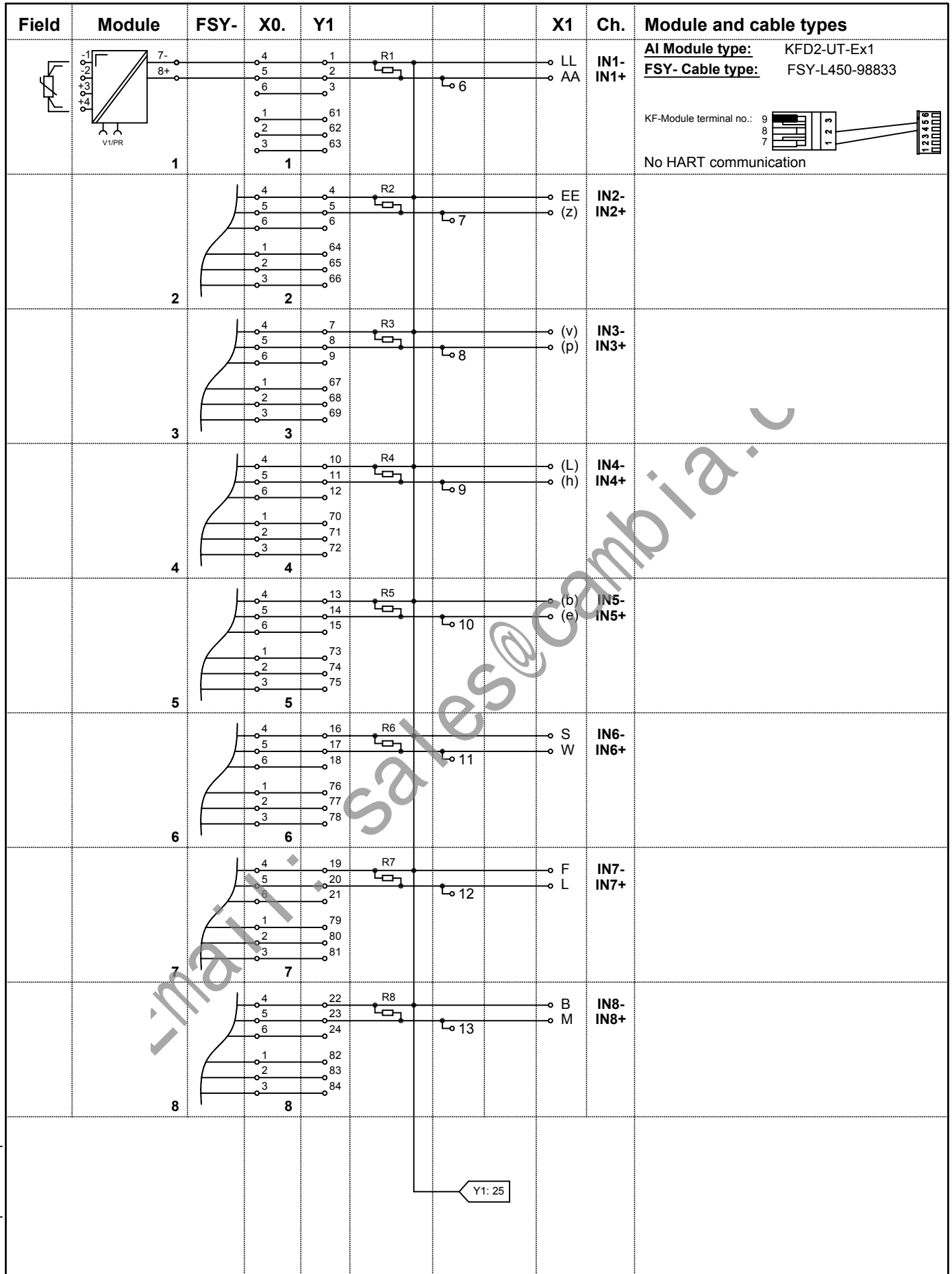

	Motherboard unit Analog Input - HART 16 channels ISTA-TR-AI-UT-370X		22.03.02	KT	vB	Sb/vB	
	Date	S TZ	Off. in ch.	contr. techn.	contr. Norm		
	Dept.: PA-VP	vB		Nr. 36-7175e			
	Up date: 17.06.08	Replaces: xxxx / 36-xxxx		Sheet 2			
MB-16U5L	Scale: - -		of 3				

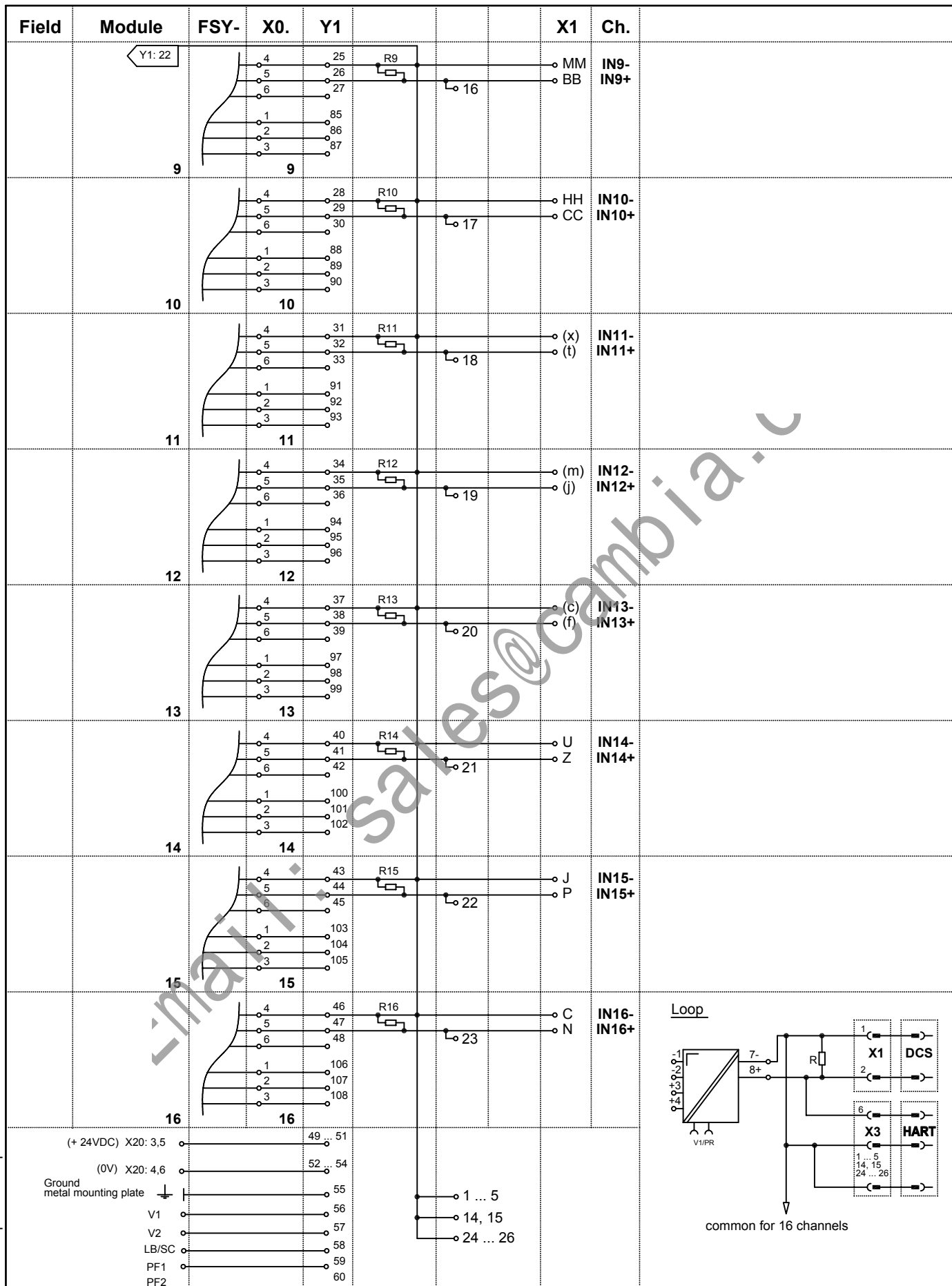

	Motherboard unit Analog Input - HART 16 channels ISTA-TR-AI-UT-370X		23.03.02	KT	vB	Sb/vB		
			Date	S TZ	Off. in ch.	contr. techn.	contr. Norm	
			Dept.: PA-VP	Nr. 36-7175e		Replaces:		
			Up date: 17.06.08	xxxx / 36-xxxx				Sheet 3
		MB-16U5L	Scale: - - -				of 3	

9. 3704E / 3720 Application

(32 + 32 channels AI)

	Page
Simplified schematic 3704E / 3720	9- 1
2 x Motherboard ISTA-TR-AI-STC-370X-118290	9- 2
Part No.:	118290
Function:	Analog Input + HART
Channels:	32
System cable:	(ELCO connector)
KF- Module:	KFD2-STC4-Ex1 (single channel)
Simplified schematic:	drawing no. 36-9290
Wiring Diagram:	drawing no. 36-7468

email: sales@cambia.a.c

3704E ANALOG INPUT MODULE

Simplified schematic of a typical 64-point analog input module (1 of 64 points shown)

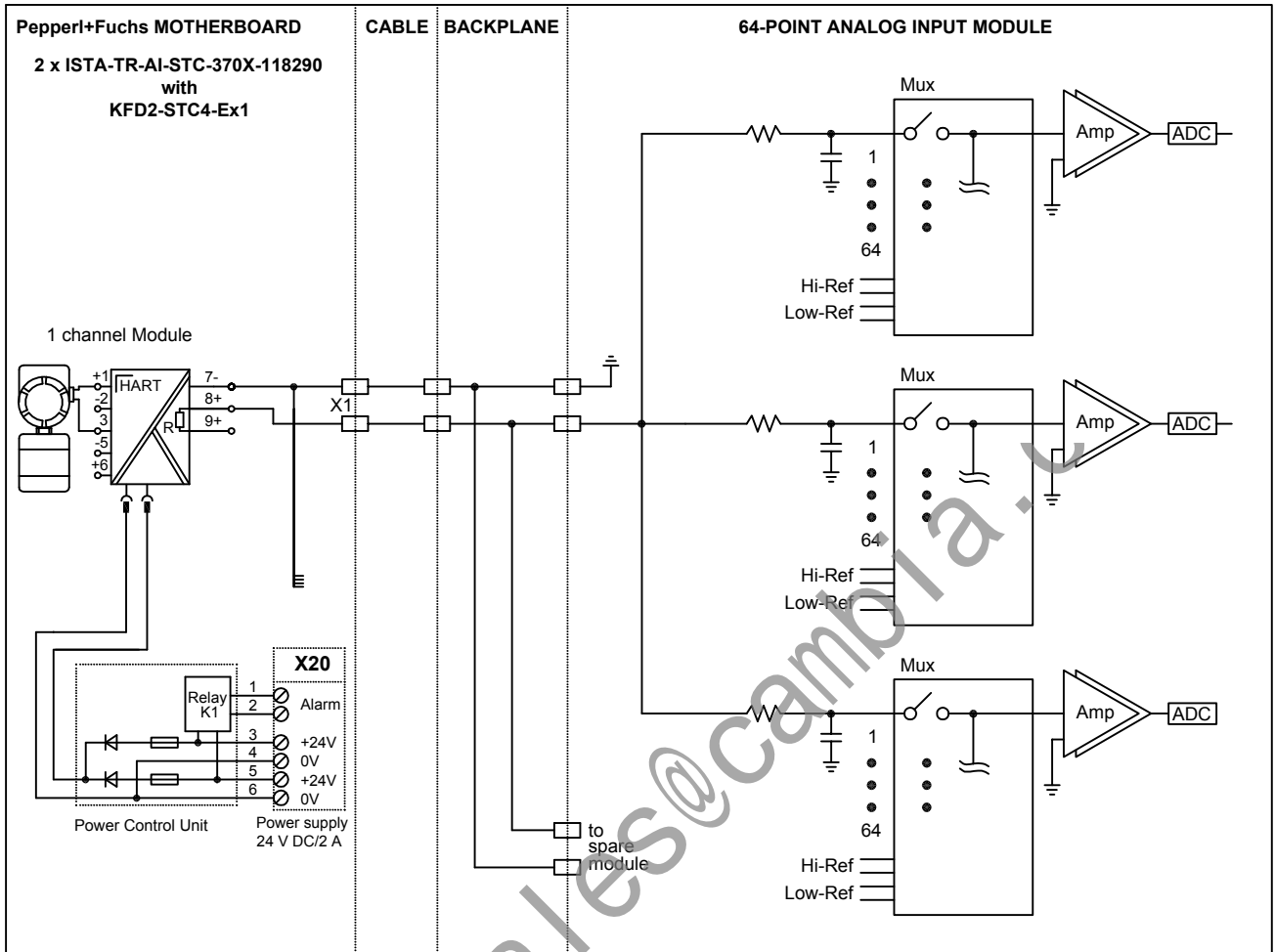

Pin assignment of connector #A (56 pin ELCO female)

Pin	AA	KK	LL	z	DD	EE	p	u	v	h	k	l	e	a
Signal	IN1	*	IN2	IN3	PWR	IN4	IN5	*	IN6	IN7	PWR	IN8	IN9	*
Pin	b	W	R	S	L	E	F	M	A	B	BB	NN	MM	CC
Signal	IN10	IN11	PWR	IN12	IN13	RTN	IN14	IN15	RTN	IN16	IN17	RTN	IN18	IN19
Pin	JJ	HH	t	y	x	j	n	m	f	d	c	Z	V	U
Signal	RTN	IN20	IN21	RTN	IN22	IN23	RTN	IN24	IN25	RTN	IN26	IN27	RTN	IN28
Pin	P	K	J	N	D	C	T	H	w	FF	r	s	X	Y
Signal	IN29	RTN	IN30	IN31	RTN	IN32	CGND	CGND	CGND	CGND	**	**	**	**

Pin assignment of connector #B (56 pin ELCO female)

Pin	AA	KK	LL	z	DD	EE	p	u	v	h	k	l	e	a
Signal	IN33	RTN	IN34	IN35	RTN	IN36	IN37	RTN	IN38	IN39	RTN	IN40	IN41	RTN
Pin	b	W	R	S	L	E	F	M	A	B	BB	NN	MM	CC
Signal	IN42	IN43	RTN	IN44	IN45	RTN	IN46	IN47	RTN	IN48	IN49	RTN	IN50	IN51
Pin	JJ	HH	t	y	x	j	n	m	f	d	c	Z	V	U
Signal	RTN	IN52	IN53	RTN	IN54	IN55	RTN	IN56	IN57	RTN	IN58	IN59	RTN	IN60
Pin	P	K	J	N	D	C	T	H	w	FF	r	s	X	Y
Signal	IN61	RTN	IN62	IN63	RTN	IN64	CGND	CGND	CGND	CGND	**	**	**	**

* Reserved for internal use. Do not connect for any purpose.
** not used
CGND is the chassis ground

19.08.99		AJ	AJ	--	
Date	S	TZ	Off. in ch.	contr. techn.	contr. Norm



D-TR-3704E

Dept.: PA-VP	Nr. 36-9290
vB/Bro	Replaces: XXXXX / 36-XXXX
Up date: 23.03.04	Sheet 1
Scale: - : -	of 1

copyright according to DIN34 unauthorized distribution and reproduction prohibited

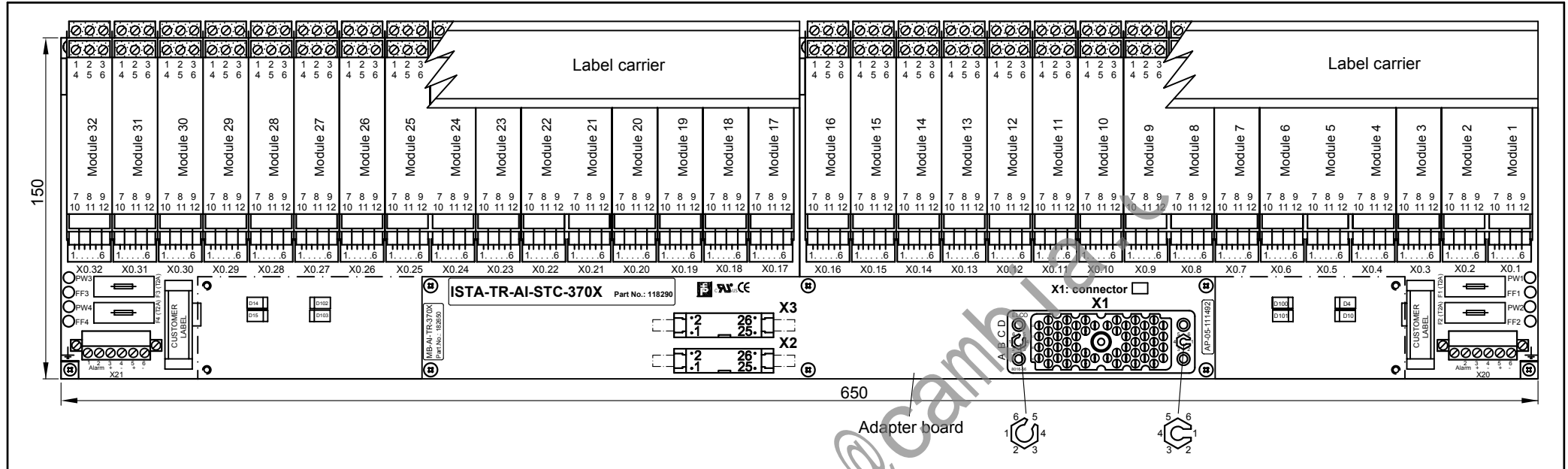

APPLICATION:

TRICONEX I/O card 3704E: will be required 2 x ISTA-TR-AI-STC-370X-118290; 64 points, commoned

Motherboard 2: connected with connector #B
 Module 1 ... 32, channels 33 ... 64

Motherboard 1: connected with connector #A
 Module 1 ... 32, channels 1 ... 32



Both power supplies (X20, X21) have to be connected

Name	Note
X1	56 pin female system connector ELCO (small key: 1, large key: 5)
X2, X3	26 pin male HART connector
X0.1 .. 32	6 pin male terminals for cable tree FSY-.....
X20, X21	Screw terminals (Power feed on X20 and X21 must be same)
X20, 1, 2 X21, 1, 2	Alarm screw terminal
F1, F2 F3, F4	Fuse
PW1,2,3,4 FF1,2,3,4	LEDs for power and power failure

Ordering information: ISTA-TR-AI-STC-370X-118290		Description
Basic components:		
32 pieces:	KFD2-STC4-Ex1 (AI)	KF-Module type (function)
1 piece:	MB-AI-TR-370X-182650	Motherboard without modules
composed by:		
1 piece:	MB-32U1-103678	Motherboard without modules, adapter board, FSY cable tree and Label carrier
1 piece:	AP-05-111492	Adapter board
2 pieces:	KFD0-LC1-16M-99144	2 x Label carrier 1
32 pieces:	FSY-L450-98833	Cable tree connection KF-Module-Motherboard



PEPPERL+FUCHS
 Mannheim-Schönau

Motherboard unit
 Analog Input - HART
 32 channels
ISTA-TR-AI-STC-370X

11.04.02		KT	vB	Sb/vB	
Date	S	TZ	Off. in ch.	contr. techn.	contr. Norm
Dept.: PA-VP	Up date: 18.06.08		Replaces: vB XXXXX / 36-XXXX		Sheet 1
MB-32U1	Scale: 1:2.5, 1:12.5		of 3		

Field	Module	FSY	X0.	Y1	X2	X1	Ch.	Field	Module	FSY	X0.	Y1	X2	X1	Ch.	
	1	1	4	1	R1	6	AA	IN1	9	9	4	25	R9	16	(e)	IN9
	2	2	4	4	R2	7	LL	IN2	10	10	4	28	R10	17	(b)	IN10
	3	3	4	7	R3	8	(z)	IN3	11	11	4	31	R11	18	W	IN11
	4	4	4	10	R4	9	EE	IN4	12	12	4	34	R12	19	S	IN12
	5	5	4	13	R5	10	(p)	IN5	13	13	4	37	R13	20	L	IN13
	6	6	4	16	R6	11	(v)	IN6	14	14	4	40	R14	21	F	IN14
	7	7	4	19	R7	12	(h)	IN7	15	15	4	43	R15	22	M	IN15
	8	8	4	22	R8	13	(L)	IN8	16	16	4	46	R16	23	B	IN16

Module and cable types

AI Module type:
 KFD2-STC4-Ex1

FSY - Cable type:

FSY-L450-98833

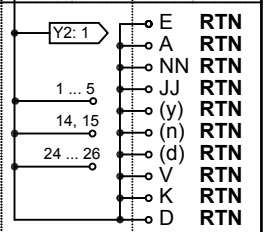
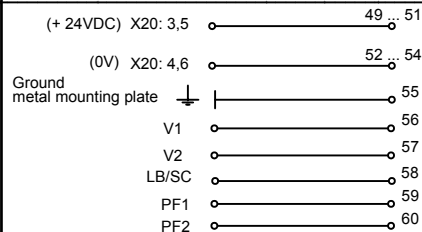

11.04.02	KT	vB	Sb/vB	
Date	S TZ	Off. in ch.	contr. techn.	contr. Norm
Dept.: PA-VP	Nr. 36-7468b			
Up date: 18.06.08	Replaces: XXXXX / 36-XXXX		Sheet 2	
MB-32U1	Scale: - : -		of 3	

Motherboard unit
 Analog Input - HART
 32 channels
ISTA-TR-AI-STC-370X

Field	Module	FSY	X0.	Y2	X3	X1	Ch.	Field	Module	FSY	X0.	Y2	X3	X1	Ch.
	17		4 5 6	1 2 3	R17	6	BB IN17		25		4 5 6	25 26 27	R25	16	(f) IN25
	18		4 5 6	4 5 6	R18	7	MM IN18		26		4 5 6	28 29 30	R26	17	(c) IN26
	19		4 5 6	7 8 9	R19	8	CC IN19		27		4 5 6	31 32 33	R27	18	Z IN27
	20		4 5 6	10 11 12	R20	9	HH IN20		28		4 5 6	34 35 36	R28	19	U IN28
	21		4 5 6	13 14 15	R21	10	(t) IN21		29		4 5 6	37 38 39	R29	20	P IN29
	22		4 5 6	16 17 18	R22	11	(x) IN22		30		4 5 6	40 41 42	R30	21	J IN30
	23		4 5 6	19 20 21	R23	12	(j) IN23		31		4 5 6	43 44 45	R31	22	N IN31
	24		4 5 6	22 23 24	R24	13	(m) IN24		32		4 5 6	46 47 48	R32	23	C IN32
								<p>(+ 24VDC) X21: 3,5 49... 51</p> <p>(0V) X21: 4,6 52... 54</p> <p>Ground metal mounting plate ↓</p> <p>V1 55</p> <p>V2 56</p> <p>LB/SC 57</p> <p>PF1 58</p> <p>PF2 59</p> <p>60</p> <p>DD } PWR,</p> <p>(k) } RTN</p> <p>R 5</p> <p>14, 15</p> <p>24... 26</p>							

R = resistor 250 Ohm 0,01%
 Note: Letters in brackets are small letters

11.04.02		KT	vB	Sb/vB	
Date	S	TZ	Off. in ch.	contr. techn.	contr. Norm
Dept.: PA-VP	vB		Nr. 36-7468b		
Up date: 18.06.08	Replaces: XXXXX / 36-XXXX		Sheet 3		
MB-32U1	Scale: - : -		of 3		

PEPPERL+FUCHS
 Mannheim-Schönau

Motherboard unit
 Analog Input - HART
 32 channels
ISTA-TR-AI-STC-370X

10. 3805E Application

(8 channels AO)

	Page
Simplified schematic 3805E	10- 1
Motherboard ISTA-TR-AO-SCD-380X-118277	10- 2
Part No.:	118277
Function:	Analog Output + HART
Channels:	8
System cable:	(ELCO connector)
KF- Module:	KFD2-SCD-Ex1.LK (single channel)
Simplified schematic:	drawing no. 36-9291
Wiring Diagram:	drawing no. 36-7464

email: sales@cambia.it

3805E ANALOG OUTPUT MODULE

Simplified schematic of a typical 8-point commoned-return analog output module
(1 of 8 points shown)

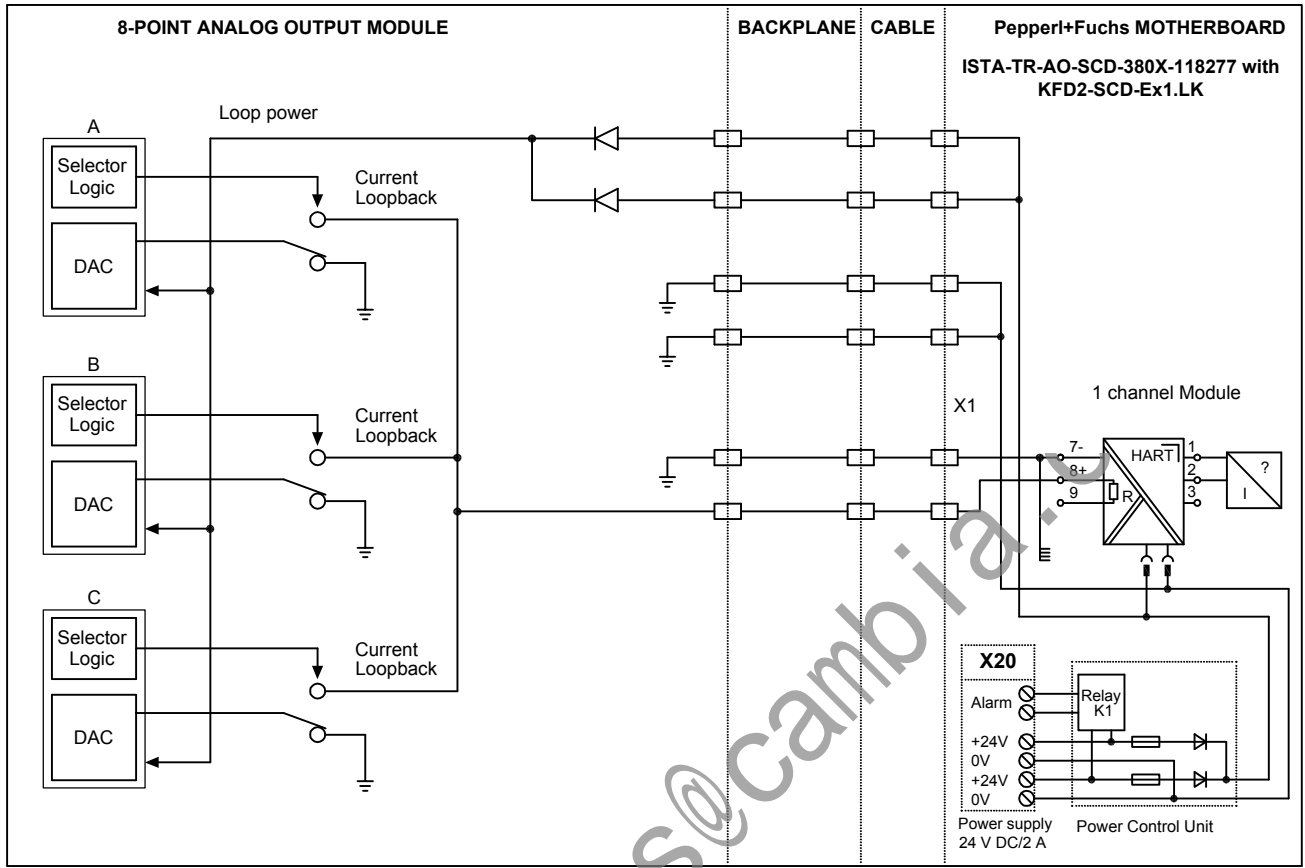

Pin assignment of connector #A (56 pin ELCO female)

Pin	AA	KK	LL	z	DD	EE	p	u	v	h	k	l	e	a
Signal	OUT1		RTN1	OUT2		RTN2	OUT3		RTN3	OUT4		RTN4	OUT5	
Pin	b	W	R	S	L	E	F	M	A	B	BB	NN	MM	CC
Signal	RTN5	OUT6		RTN6	OUT7		RTN7	OUT8		RTN8				
Pin	JJ	HH	t	y	x	j	n	m	f	d	c	Z	V	U
Signal			PWRA		RTN	PWRB		RTN						
Pin	P	K	J	N	D	C	T	H	w	FF	r	s	X	Y
Signal							CGND	CGND	CGND	CGND	**	**	**	**

** not used

CGND is the chassis ground

02.03.99	AJ	AJ	--	
Date	S	TZ	Off. in ch.	contr. techn.
Dept.: PA-VP	Nr. 36-9291			
Up date: 23.03.04	vB/Bro	Replaces: XXXXX / 36-XXXX		Sheet 1
	Scale:	- : -	of 1	



PEPPERL+FUCHS
Mannheim-Schönau

D-TR-3805E

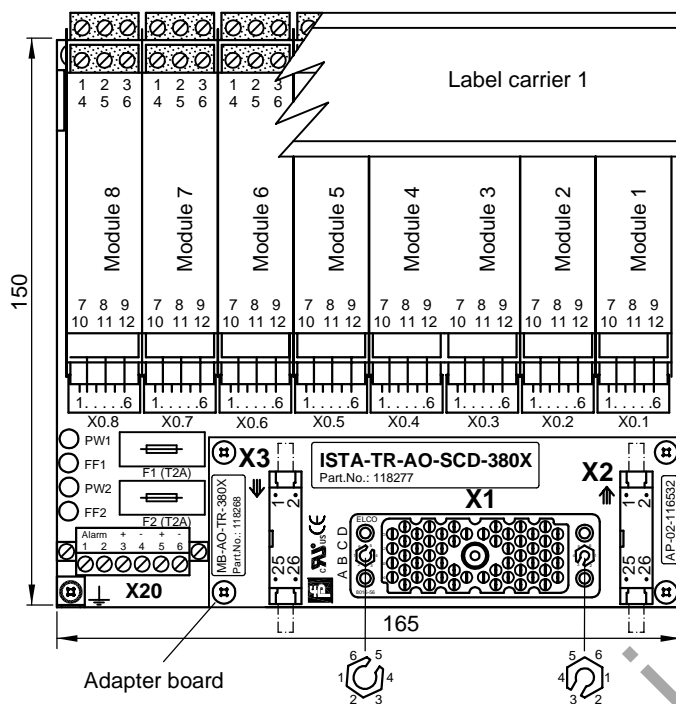

APPLICATION:

TRICONEX I/O card 3805E:
8 points

Name	Note
X1	56 pin female system connector ELCO (small key: 3, large key: 5)
X2, X3	26 pin HART connector male
X0.1 16	6 pin male terminals for cable tree FSY....
X20.3 6	Power supply screw terminals
X20.1, X20.2	Alarm screw terminal
F1, F2	Fuse
PW1, PW2, FF1, FF2	LEDs for power and power failure

Ordering information: ISTA-TR-AO-SCD-380X-118277

Basic components:	Description
8 pieces: KFD2-SCD-Ex1.LK (AO)	KF-Module type (function)
1 piece: MB-AO-TR-380X-118268	Motherboard without modules
composed by:	
1 piece: MB-8U2-Y97680	Motherboard without modules, adapter board, FSY cable tree and Label carrier
1 piece: AP-02-116532	Adapter board
1 piece: KFD0-LC1-8M-99143	Label carrier 1
16 pieces: FSY-L450-98833	Cable tree connection KF-Module-Motherboard

copyright according to DIN34
unauthorized distribution and reproduction prohibited

	PEPPERL+FUCHS Mannheim-Schönau	Motherboard unit Analog Output - HART 8 channels ISTA-TR-AO-SCD-380X	14.03.02	KT	vB	vB/Sb	
			Date	S TZ	Off. in ch.	contr. techn.	contr. Norm
		Dept.: PA-VP	Nr. 36-7464A				
		Up date: 23.03.04	Replaces: xxxxxx / 36-xxxx		Sheet 1		
		MB-8U2	Scale: 1 : 2		of 2		

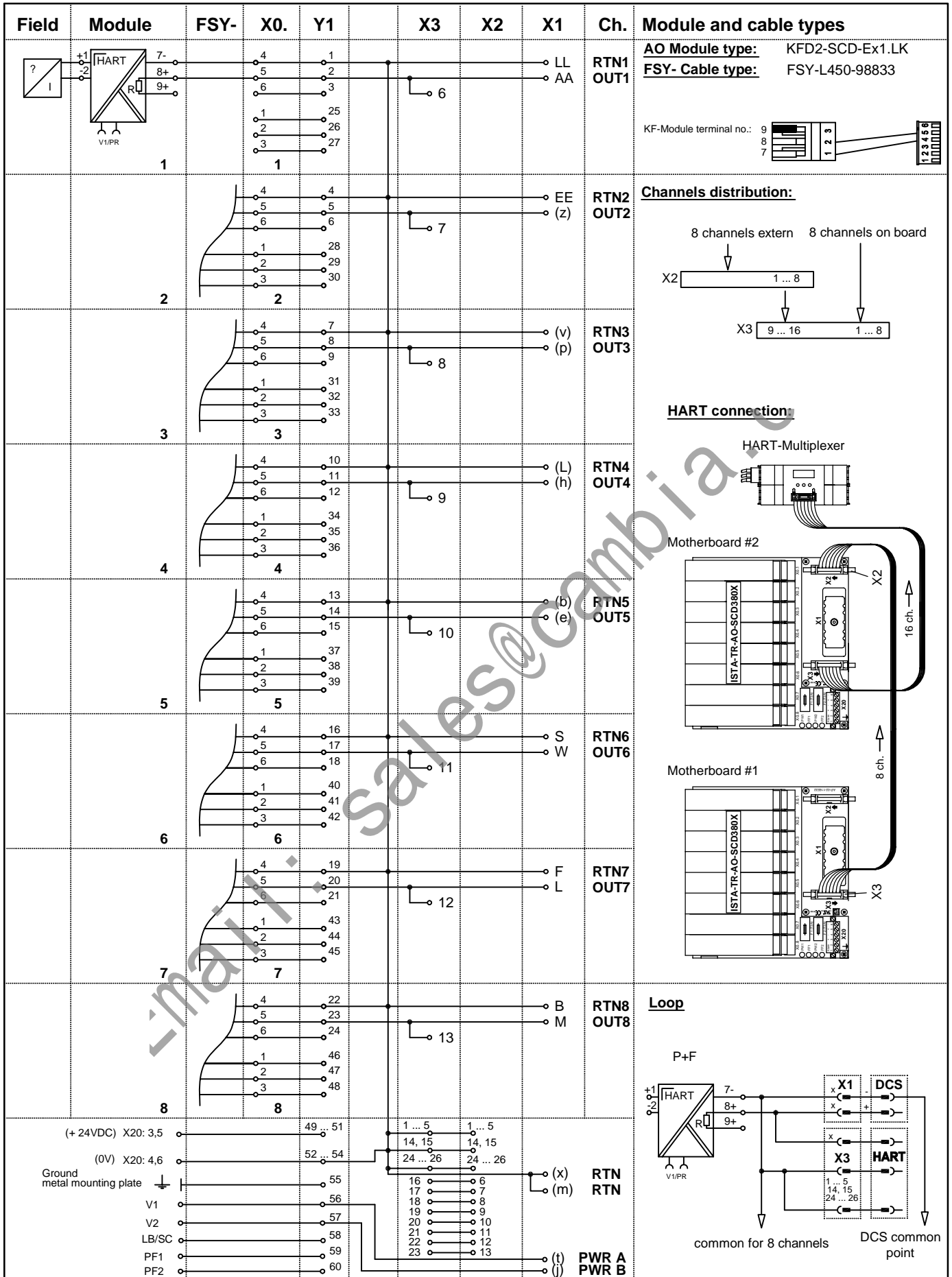

PEPPERL+FUCHS
Mannheim-Schönau

Motherboard unit
Analog Output - HART
8 channels
ISTA-TR-AO-SCD-380X

22.03.02	KT	vB	Sb/vB	
Date	S TZ	Off. in ch.	contr. techn.	contr. Norm
Dept.: PA-VP	Nr. 36-7464A			
Up date: 22.10.04	Sb	Replaces: xxxxx / 36-xxxx	Sheet 2	
	Scale:		of 2	

11. Cabinet assembly

	Page
Cabinet assembly with Motherboard and HART 320 I / O.....	11- 1
Cabinet assembly with Motherboard, marshalling and redundant power supply	11- 2

Email: sales@cambia.com

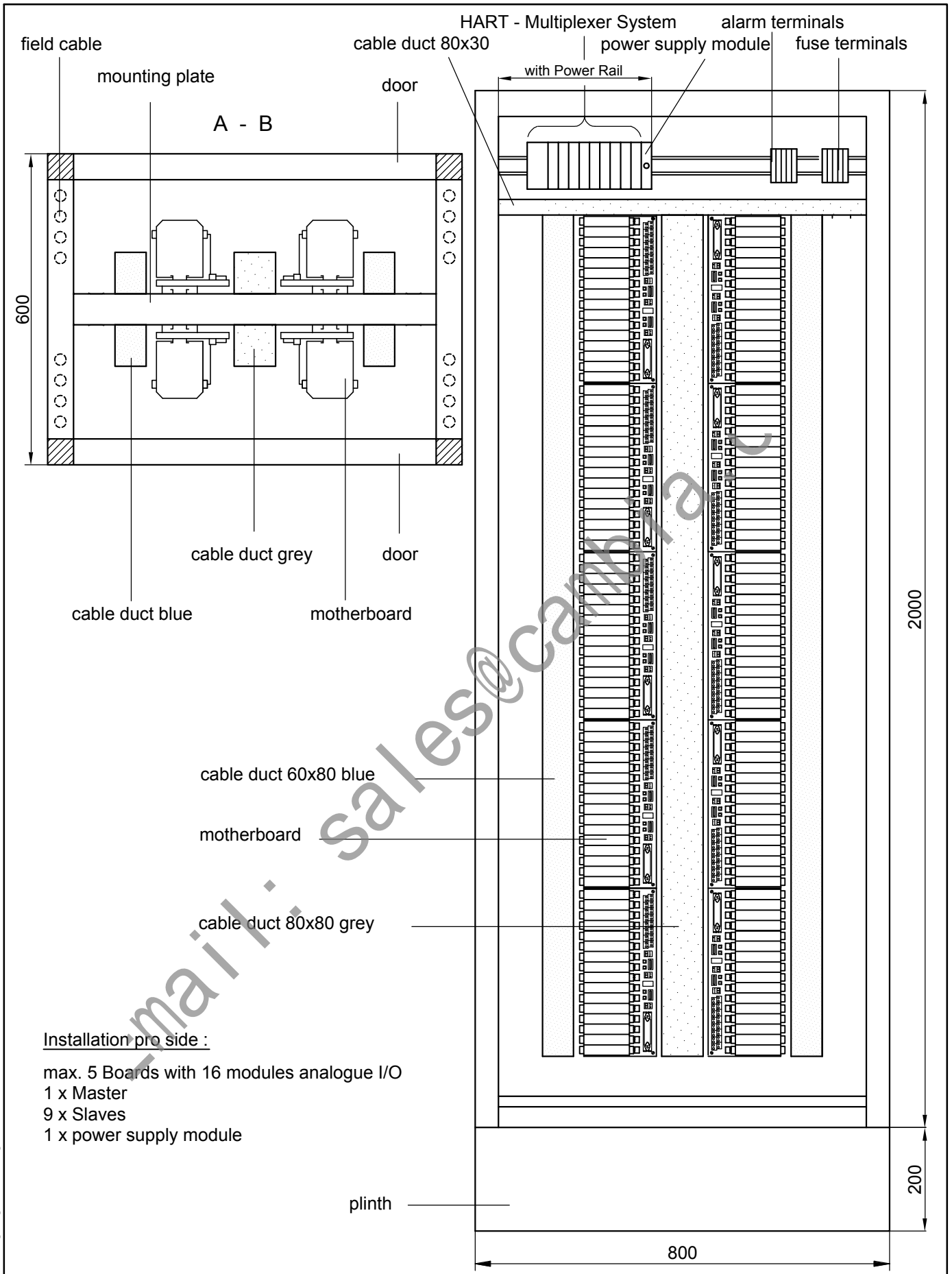

Installation pro side :

- max. 5 Boards with 16 modules analogue I/O
- 1 x Master
- 9 x Slaves
- 1 x power supply module

		14.09.98		AJ		vB	
Ind.	Änderung	Datum	S	TZ	Sachbearb.	gepr. techn.	gepr. Norm
 PEPPERL+FUCHS Mannheim-Schönau		cabinet assembly with motherboards and HART - Multiplexer for 320 Input / Output			Abt.:	Nr. TAB157	Ind. TR
		Part.Nr.:		Ersatz für:		Blatt	
					Maßstab: 1 : 10	von	

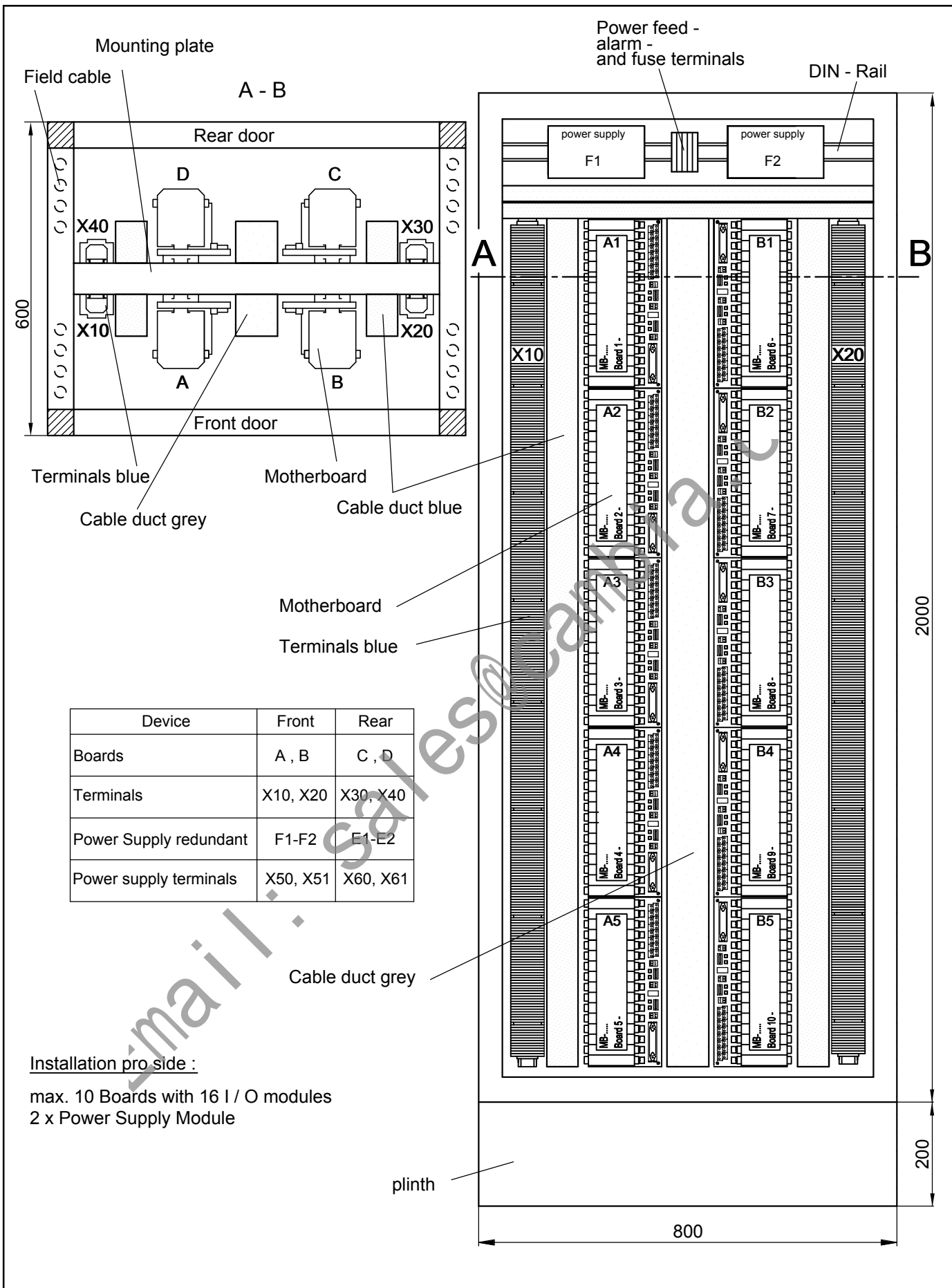

Device	Front	Rear
Boards	A , B	C , D
Terminals	X10, X20	X30, X40
Power Supply redundant	F1-F2	E1-E2
Power supply terminals	X50, X51	X60, X61

Installation pro side :

max. 10 Boards with 16 I / O modules
2 x Power Supply Module

Urheberschutz nach DIN 34
Weitergabe sowie Vervielfältigung ist nicht gestattet

PF	PEPPERL+FUCHS Mannheim-Schönau	Cabinet assembly for max. 320 I / O with motherboards , marshalling and redundant Power Supply	14.09.98		AJ	AJ	AJ	
			Datum	S	TZ	Sach- bearb.	gepr. techn.	gepr. Norm
			Abt.: PA-VP		Nr. TAB174		Ind. TR	
			Part.Nr.:		Ersatz für:		Blatt 1	
					Maßstab: 1 : 10		von 1	

12. Accessories

	Page
Label Carrier	12- 1
Sheidling busbar	12- 2

Email: sales@cambia.a.c

Label Carrier

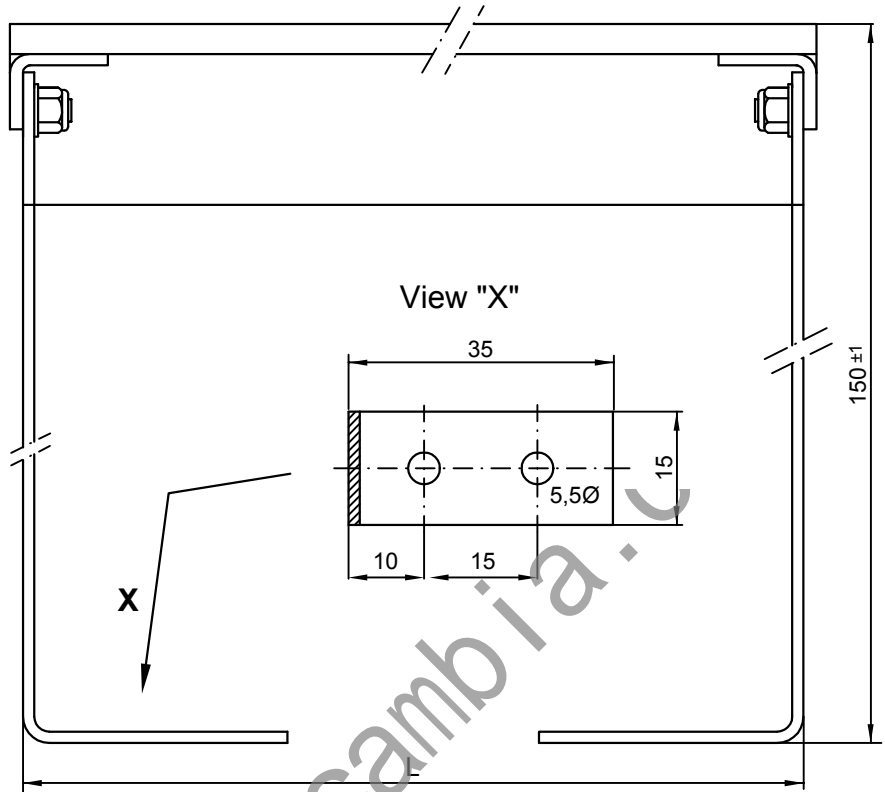
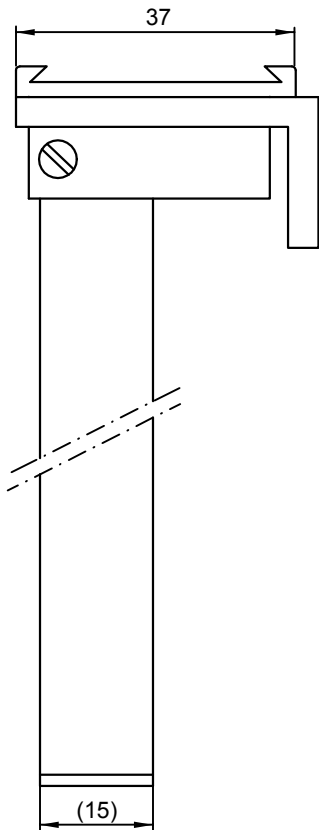

Customer marking area:
pro module 29mm x 20mm

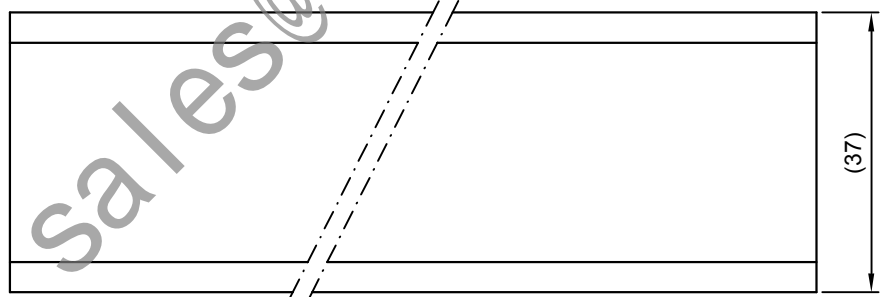

Label Carrier KFD0-LC-...			
L	Part.-No.	Name	Note
up to 50 cm	108878	KFD0-LC1-x-xxxxx	(*) customized (XXX = length in cm)
51 to 100 cm	108879	KFD0-LC1-x-xxxxx	(*) customized (XXX = length in cm)
(*) in case of order; delivery time 2-4 weeks			

copyright according to DIN34
unauthorized distribution and reproduction prohibited

		29.01.01		DN	vB	Sb/vB	
		Date	S	TD	Off. in ch.	contr. techn.	contr. Norm
 PEPPERL+FUCHS Mannheim-Schönau	Label Carrier	Dept.:	PA-VP		No. 36-9146		Ind. B
		Up date:	13.08.01		Replaces: xxxxxx / 36-xxxx		Sheet 1
					Scale: 1 : 1		of 1

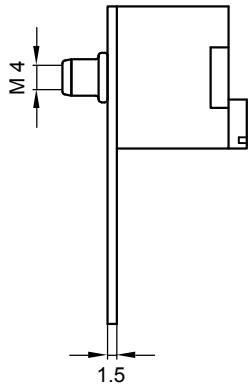
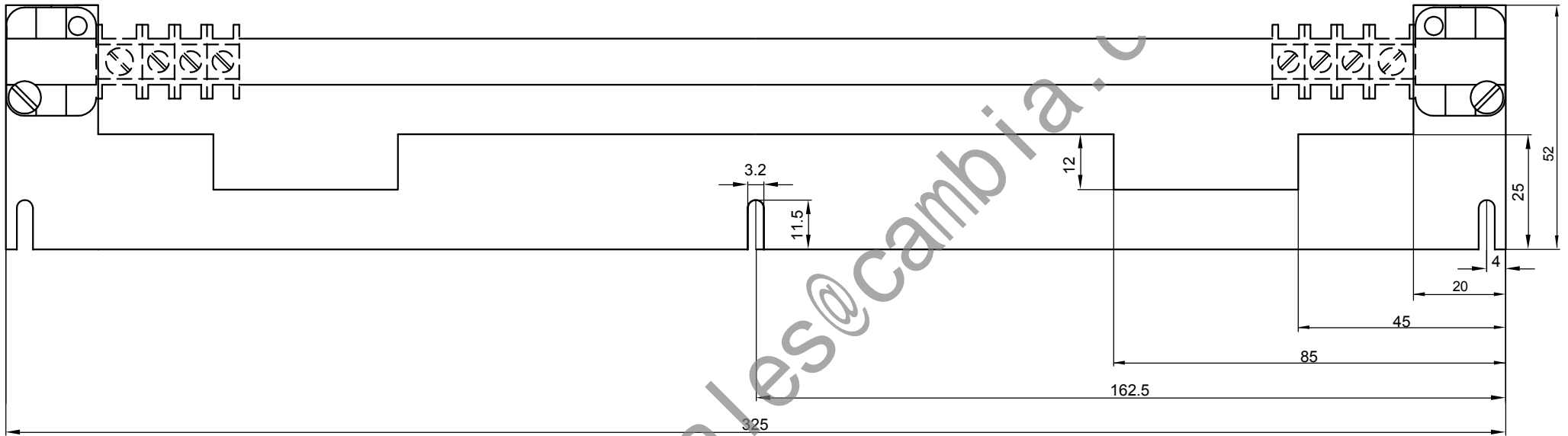

email: sales@cambia.com

12-2

A : vB		09.09.99		MB		MB	
Ind. Änd.		Date	S	TZ	Off. in ch.	contr. techn.	contr. Norm
 PEPPERL+FUCHS Mannheim-Schönau	Motherboard - Sheidling busbar for 16 Modules MBE-16-Y44009	Dept.: PA - VP	Nr. 36-9093		Ind. A		
		Part no.:	Replaces:		Sheet		
		MB U4	Scale:	1 : 1		of	

13. Test certificate

	Page
Test certificate.....	13- 1

Email: sales@cambia.a.c

Notes:

This catalogue contains only the Motherboards specified in the agreement with Invensys.

Further Motherboards with different functions are available on request.

Email: sales@cambia.a.c

(Proposal)

Test certificate

On June 15th 1999 have been tested succesfully the Pepperl+Fuchs Interface-Boards with Triconex I/O cards. Type names of each device see table below.

It was a 100 % test. Each channel was tested by connecting the accordingly signal to the field side of P+F modules and was shown by a test programme on Triconex system monitor.

Triconex I/O card	P+F Motherboard	P+F module	Signal
3503E / 3505E * ²⁾	ISTA-TR-DI-350X-118289	KFD2-SH-Ex1.T.OP (1-channel module)	32 point. Digital Input 24 V DC
	ISTA-TR-DI-SRLB-350X-122110	KFD2-SR2-Ex1.W.LB (1-channel module)	16 point. Digital Input 24 V DC
	ISTA-TR-DI-SR2-350X-118271* ¹⁾	KFD2-SR2-Ex2.2S (2-channel module)	16 + 16 point. Digital Input 24 V DC
	ISTA-TR-DI-SR2-350X-118272* ¹⁾	KFD2-SOT2-Ex2 (2-channel module)	16 + 16 point. Digital Input 24 V DC
3504E / 3564 * ²⁾	ISTA-TR-DI-SR2-35XX-118278	KFD2-SR2-Ex2.2S (2-channel module)	32 + 32 point. Digital Input 24 V DC
	ISTA-TR-DI-SOT2-35XX-118279	KFD2-SOT2-Ex2 (2-channel module)	32 + 32 point. Digital Input 24 V DC
3511	ISTA-TR-DI-350X-118289	KFD2-SH-Ex1.T.OP (1-channel module)	32 point. Digital Input 24 V DC
3604E	ISTA-TR-DO-SD-36XX-118274	KFD2-SD-Ex1.48... (1-channel module)	16 point. Digital Output 24 V DC
	ISTA-TR-DO-SL2-36XX-118273	KFD2-SL2-Ex2.B (2-channel module)	16 + 16 point. Digital Output 24 V DC
	ISTA-TR-DO-SL2-36XX-118288	KFD2-SL2-Ex2 (2-channel module)	16 point. Digital Output 24 V DC
3664 * ²⁾	ISTA-TR-DO-SD-36XX-118274	KFD2-SD-Ex1.48... (1-channel module)	16 + 16 point. Digital Output 24 V DC
	ISTA-TR-DO-SL2-36XX-118273	KFD2-SL2-Ex2.B (2-channel module)	32 point. Digital Output 24 V DC
	ISTA-TR-DO-SL2-36XX-118288	KFD2-SL2-Ex2 (2-channel module)	32 point. Digital Output 24 V DC
3700 / 3700A / 3701 * ²⁾	ISTA-TR-AI-STC-370X-118275 Incl. 1 HART connector	KFD2-STC4-Ex1 (1-channel module)	16 + 16 point. Analog Input 0/4 ... 20 mA
	ISTA-TR-AI-UT-370X-118276 Incl. 1 HART connector	KFD2-UT-Ex1 (1-channel module)	16 + 16 point. Analog Input 24 V DC
3703E	ISTA-TR-AI-STC-370X-118275 Incl. 1 HART connector	KFD2-STC4-Ex1 (1-channel module)	16 point. Analog Input 0/4 ... 20 mA
	ISTA-TR-AI-UT-370X-118276 Incl. 1 HART connector	KFD2-UT-Ex1 (1-channel module)	16 point. Analog Input 24 V DC
3704E * ²⁾	ISTA-TR-AI-STC-370X-118290 Incl. 2 HART connector	KFD2-STC4-Ex1 (1-channel module)	32 point. Analog Input
3805E	ISTA-TR-AO-SCD-380X-118277 Incl. 2 HART connector	KFD2-SCD-Ex1.LK (1-channel module)	8 point. Analog Output 4 ... 20 mA

*¹⁾ Motherboard with two pick off (see Datasheet 36-7169, 36-7413)

*²⁾ I/O card requieres 2 Boards

Irvinie (Date)

Mannheim (Date)

Stamp/Signature

Stamp/Singnature